

# USER MANUAL

## Rewinder XLP

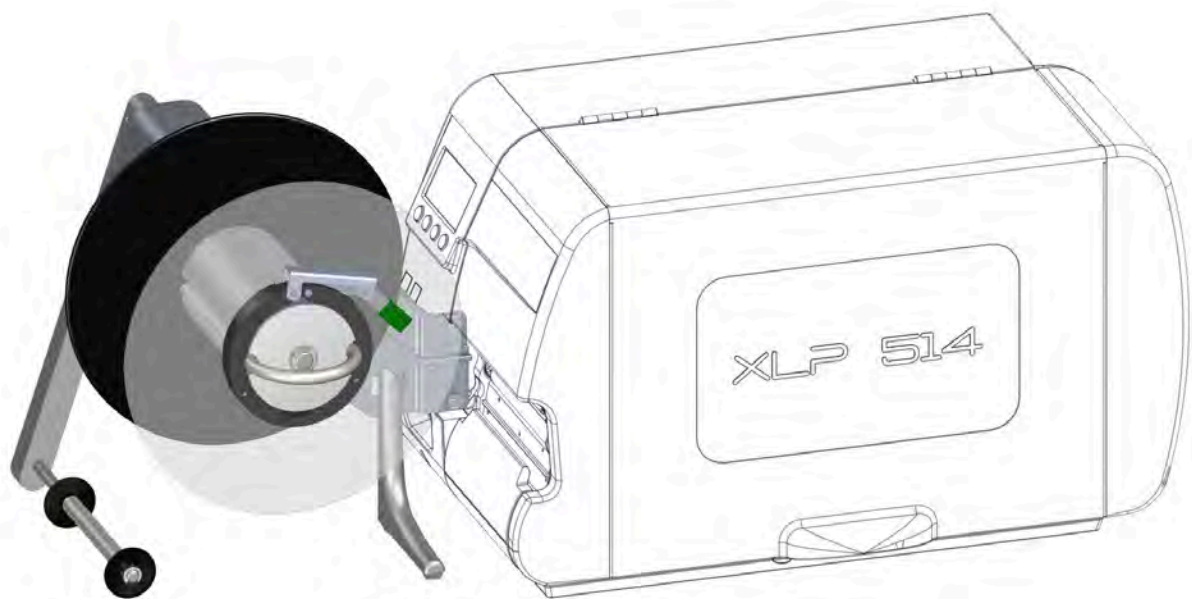

# Contents

## **Please note! - 3**

General notes - **3**

Validity of this manual and required compliance - **3**

How information is represented - **4**

Safety Notes - **5**

## **Product description - 6**

Proper usage - **6**

Operating components - **6**

Functioning - **7**

Technical data - **8**

System requirements - **8**

## **Setting up - 10**

Fitting the rewinder - **10**

Activating/deactivating the rewinder - **13**

Setting the dancer arm sensor - **14**

## **Operation / Malfunction / Cleaning - 15**

Inserting material - **15**

Starting/Stopping - **17**

Troubleshooting - **18**

Cleaning - **18**

# Please note!

## GENERAL NOTES

### Validity of this manual and required compliance

#### Contents

The complete operating manual for the attachment rewinder (referred to in the following as “rewinder”) consists of the following parts:

Manual	Target group	Medium	Availability
User manual	Operating personnel	PDF file	NOVEXX Solutions website <a href="http://www.novexx.de">www.novexx.de</a>
Service manual	Service personnel		NOVEXX Solutions Partner Portal <a href="http://www.novexx.com">www.novexx.com</a>
Spare parts catalogue			

The present *user manual* refers exclusively to the rewinder. It is intended to help in proper installation and operation of the rewinder.

For information on configuring the printer for operation with a rewinder, see the operating manual of the printer.

For technical questions not covered in this user manual:

- ▶ Follow the instructions of the service manual for the rewinder and for the applied printer or
- ▶ Request a service technician from our sales partner.

Our sales partner's customer service department is available especially for configuration settings and malfunctions.

#### Liability

NOVEXX Solutions reserves the right:

- To make changes in design and components, and to use equivalent other parts than those specified in line with technological progress.
- To change information in this manual.

Any obligation to extend these changes to machines previously delivered is excluded.

#### Copyright

NOVEXX Solutions retains all rights to this manual and its appendices. Reproduction, reprint or any other type of duplication, including parts of the manual, are permitted only with written approval.

#### Manufacturer

Novexx Solutions GmbH  
 Ohmstrasse 3  
 D-85386 Eching, Germany

Tel.: +49-8165-925-0

Fax: +49-8165-925-231

[www.novexx.com](http://www.novexx.com)

## How information is represented

### Explanation of symbols

To enhance readability and make information easier to find, different types of information are identified:

▶ Instruction with no order of tasks assigned

1. Numbered instructions introduced by preceding text

2. The specified order must be followed!

|| Special note for action that must be performed. ||

• Enumeration of features

• Other feature

 The Experts symbol identifies activities that are reserved exclusively for qualified and specially trained personnel.

### Warning Notes

Warning notes are specially highlighted::



**WARNING!**

Warning notes with the signal word **WARNING** refer to risks that can result in severe or fatal injuries! The note contains safety measures to protect affected persons.

▶ Instructions must be followed without exception.

|| **CAUTION!** ||

Warning notes with the signal word **CAUTION** refer to risks that can result in property damage or personal injury (minor injuries). The note contains instructions for preventing damage.

▶ Instructions must be followed without exception.

### Illustrations

Illustrations appear in the text where required. References to the illustrations are shown in brackets, if necessary (see table).

Reference to illustration	Application
none	<ul style="list-style-type: none"> <li>• Only one illustration</li> <li>• Reference to the illustration is obvious</li> <li>• No position number in the illustration</li> </ul>
(A)	<ul style="list-style-type: none"> <li>• Only one illustration</li> <li>• Reference to the illustration is obvious</li> <li>• Position number in the illustration</li> </ul>

Reference to illustration	Application
(see fig. above)	<ul style="list-style-type: none"> <li>• Several illustrations</li> <li>• No position number in the illustration</li> </ul>
(see fig. above, pos. A)	<ul style="list-style-type: none"> <li>• Several illustrations</li> <li>• Position number(s) in the illustration</li> </ul>

Table 1: Different references to illustrations.

### Parameters

Parameters in the parameter menu are represented in the format **Menu name > Parameter name** in grey type.

## SAFETY NOTES



**WARNING!**

Rotating shaft!

Danger of hair and clothing being pulled in by unintentional actuation of the rewinder.

- ▶ Switch off the printer and disconnect the power cable before fitting the unwinder.
- ▶ Don't wear loose long hair (if necessary, wear a hairnet).
- ▶ Keep loose jewellery, long sleeves, etc. away from the rewinder.
- ▶ Only operate the rewinder, if it is fitted firmly to the printer.



**WARNING!**

(XLP 51x) Tipping hazard!

Risk of injury from falling printer if support foot is used improperly.

- ▶ Attach the support foot as described in the instructions.
- ▶ Make sure that the support foot is supported on level solid ground.

**CAUTION!**

Bending the dancer arm causes malfunction of the rewinder

- ▶ Don't use the dancer arm at the ready fit rewinder as a carrying handle for the printer.



The safety instructions above apply in particular to the rewinder. For safe operation of the relevant printer with connected rewinder, it is essential to also read and observe the safety instructions in the user manual of the printer.

# Product description

## PROPER USAGE

The option „Rewinder XLP“ (called *rewinder* afterwards) is a peripheral device for label printers of the XLP 51x and XLP 60x series. The device is designed for winding up label material after it has been printed using one of the named printer types.

The *rewinder* is permanently attached to the printer. The printer provides power for the *rewinder* motor via a socket on the front, which is also used for receiving signals relating to the lateral deflection of the dancer arm.

## OPERATING COMPONENTS

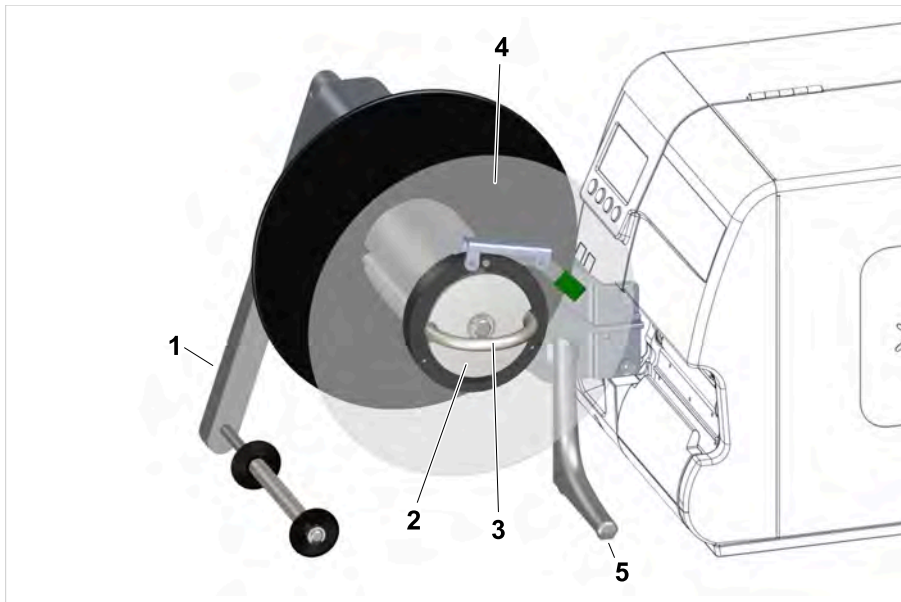

Fig. 1: Operating components of the “Rewinder XLP” (for XLP 514).

Pos.	Description
1	<i>Dancer arm</i> : Keeps the material web tensioned and controls the winding speed
2	<i>Rewind core</i> : Available in 38 mm (1.5") or 76 mm (3") diameters
3	<i>Clamping bar</i> : Fixes the beginning of the material web to the rewind core
4	<i>Material guide disc</i> : Ensures straight winding of the material web (Prevents “telescoping”)
5	<i>(XLP 51x only) Supporting leg</i> : Supports the printer forward; the support foot must not hang in the air!

## FUNCTIONING

### Speed control

During winding, the rotational speed is controlled via the deflection of the dancer arm from the rest position. The greater the deflection, the lower the rotational speed. If the label material sags – the dancer arm is in this case only slightly deflected – the rewinder increases the rotational speed in order to make up the “delay”. This ensures that the label material is rolled up evenly tautly. Without lateral deflection - e.g. when the material is finished – the rewinding process stops after about four seconds.

In the mode “Printing inside”, material does not wrap itself around the dancer arm as much as is the case with “Printing outside”. Particularly with larger roll diameters, the dancer arm would often shoot from one extreme position to the other. The material would then be wound up in a jolting manner.

For this reason, the software is adjusted when “Printing inside” is selected – it then only uses approximately 50% of the maximum dancer arm deflection for controlling the motor.

### Direction of rotation

The label material can be alternately rolled up with the labels facing outwards (left picture) or inwards (right picture) by reversing the direction of rotation.

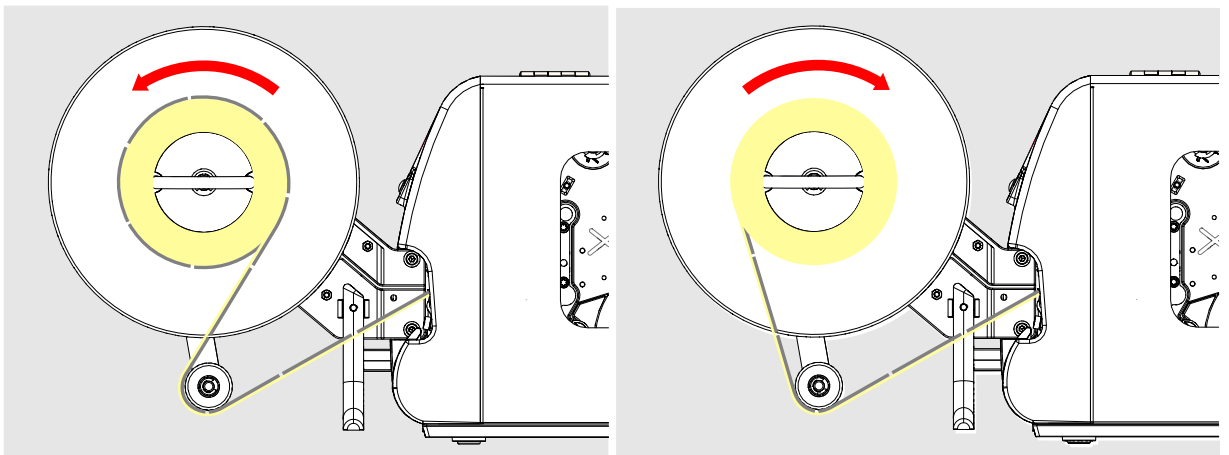

Fig. 2: Rotation direction “Printing outside” (left) and “Printing inside” (right).

### Rotational speed

The rotational speed of the rewinder depends on the print speed. A low print speed leads to a slower rewinder rotation as a high print speed. An exception to this rule is the rotational speed directly after starting the wind-up process.

## TECHNICAL DATA

<b>Motor</b>	Stepper motor
<b>Position sampling</b>	Hall sensor
<b>Rotation direction</b>	Rewind direction with label facing outside or inside
<b>Rewind speed</b>	Core diameter 38 mm (1.5"): max. 305 mm/s (12 inch/s) Core diameter 76 mm (3"): no limitation
<b>Noise level</b>	< 70dB(A)
<b>Material roll</b>	See table:

Max. outer Ø	230 mm
Core inner Ø	38/76 mm (1,5/3")
Min. material width	= Minimal print width
Max. material width	= Width of the rewinding mandrel (120/185 mm)
Max. roll weight	5 kg

## SYSTEM REQUIREMENTS

Rewinders in the appropriate width can be operated at the following printer types:

Printer	Rewinder width	Core Ø	Article number
XLP 514	4"	38 mm (1.5")	N103130
		76 mm (3")	N103131
XLP 516	6"	38 mm (1.5")	N103137
		76 mm (3")	N103138
XLP 604	4"	38 mm (1.5")	N103394
		76 mm (3")	N103395
XLP 605/606	6"	38 mm (1.5")	N103396
		76 mm (3")	N103397

Preparation for peripheral devices:

For using the printers with a rewinder, they must be especially equipped. This so called peripherals preparation consists mainly of an additional output stage board for the motor of the peripheral device and of some additional connection cables. From the outside, the peripheral preparation can be identified by the D-Sub connector (A) on the front side of the printer:





Fig. 3: The D-Sub connector (A) is an indicator for the peripheral preparation of the printer.

# Setting up

## FITTING THE REWINDER

The rewinder is attached to the front of the printer with two screws. At the XLP 51x, a support leg absorbs some of the strain exerted by the material roll.

### Before you begin

Tools:

- Hex screwdriver, 3 and 4 mm

Prerequisites:

- Place the printer on a level surface.
- (XLP 51x) Ensure that there is enough room in front of the printer for the support leg of the rewinder.

### About this task



**WARNING!**

Rotating shaft!

Danger of hair and clothing being pulled in by unintentional actuation of the rewinder.

- ▶ Switch off the printer and disconnect the power cable before fitting the unwinder.

### Procedure

1. Remove the cover (A) of the mounting flange. To do this, turn out the two screws (B).

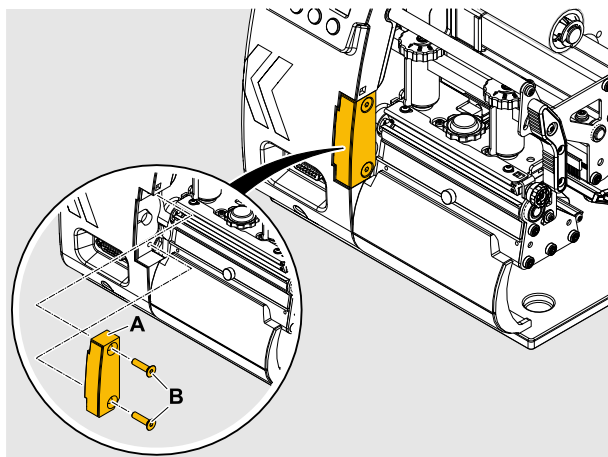

- Remove the guide disk (A). To do so, open the clamping lever (B). Remove the clamping bar (C).

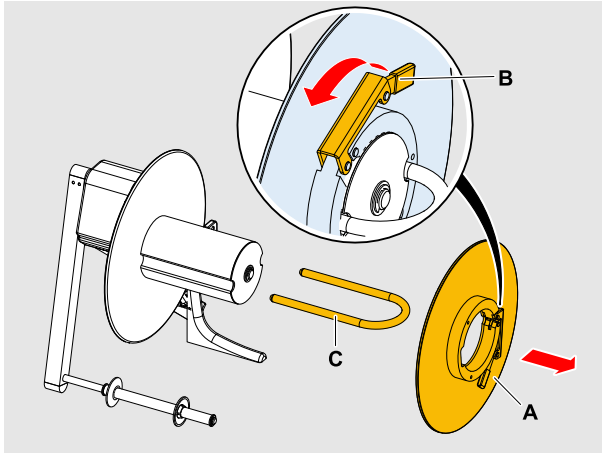

- Attach the rewinder to the printer flange using the two screws (A) supplied (M5x25).

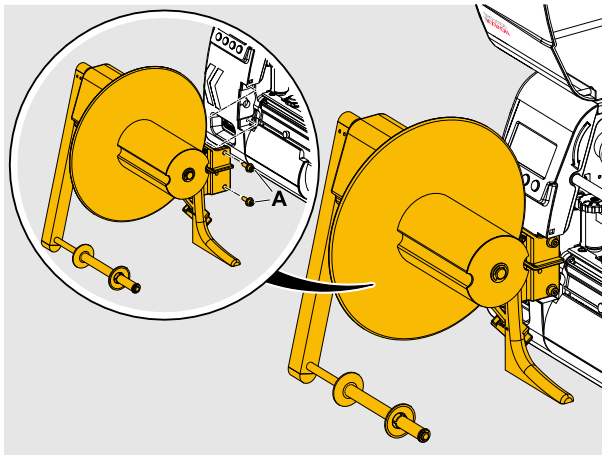

- (XLP 51x) Loosen the supporting leg fastening screw (A). Push down the support leg (B) until it stands on the surface. Push up the rewinder a little and at the same time tighten the fastening screw.

|| The weight of the material roll should rest on the support leg.  
|| The support leg must not hang in the air! ||

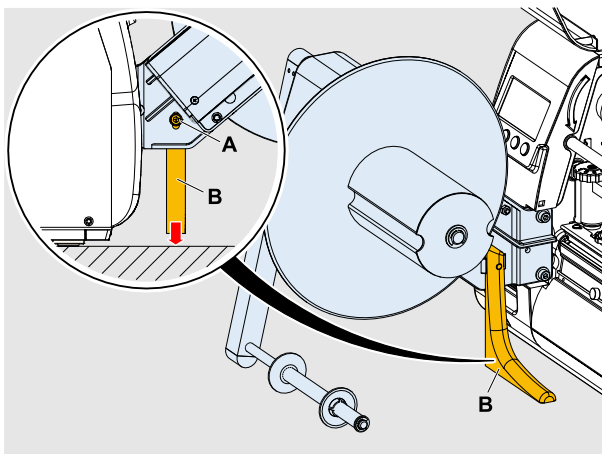

5. Plug in the connector plug (A).

**CAUTION!**

Damage to the device electronics

- ▶ Under no circumstances should the plug be attached or removed when the device is switched on.

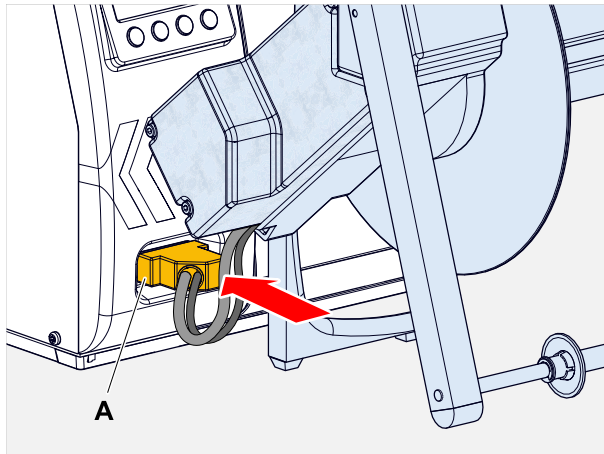

## ACTIVATING/DEACTIVATING THE REWINDER

### Before you begin

The rewinder is ready fit and connected. The printer is switched on.

### About this task

After fitting it to the printer, the rewinder has to be activated. This is done by setting the appropriate parameter in the parameter menu of the printer.

### Procedure



#### Activating the rewinder:

1. Set **Options > Selection > Periph. device** to "Extern Rewinder".  
|| Don't confuse with the setting **Intern. rewinder** that activates the internal rewinder of the printer. ||

Afterwards, **Options > Rewinder > Rewind direction** is called automatically.

2. Select the desired rotating direction ("Printing inside" or "Printing outside").  
|| Default setting = "Printing outside" ||

The printer restarts. Afterwards, the following has changed:

- An additional submenu **Options > Rewinder** appeared, which contains the parameter **Rewind direction** that is required to set the rotation direction of the rewinder.
- The icon  is visible above key 3. By pressing this key, the rewinder can be stopped and started again (alternates with icon .

|| After the restart of the printer starts the rewinder to rotate. If no label material is inserted, an error warning will follow, because the printer control assumes torn-off material.

▶ Acknowledge the error message.

|| After acknowledging the error message, the rewinder can be started/stopped by pressing key 3.

#### Deactivating the rewinder:

3. Set **Options > Selection > Periph. device** to "None".

XLP 60x Without ribbon saving option from firmware version BEL-V6.0 onwards:

After deactivating a peripheral device (**Options > Selection > Periph. device** = "None"), the stepper motor output stage must be reassigned its function. The following dialog appears:



▶ Select "Peripheral" and confirm with key 4.

## SETTING THE DANCER ARM SENSOR

### About this task

The dancer arm controls the winding speed of the rewinder by means of a sensor. Before applying the rewinder for the first time, the dancer arm has to be moved in both end positions to adjust the sensor.

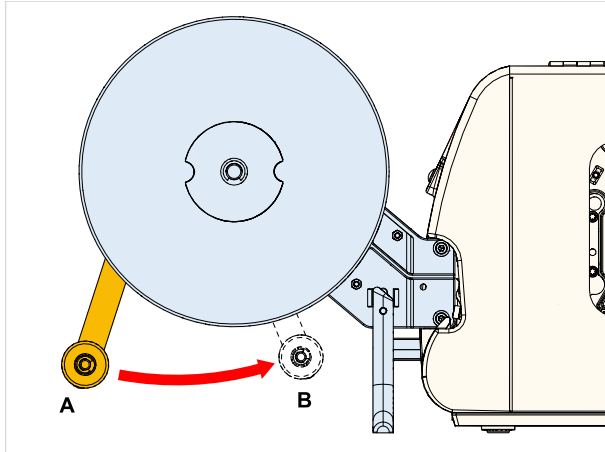

Fig. 4: "Loose position" (A) and "Tight position" (B) of the dancer arm.

### Procedure

1. Ensure that the dancer arm can move unhindered to position A (picture above, A) driven by the spring force.
2. Call parameter Options > Rewinder > Rewinder adjust. Display <sup>[1]</sup>:



3. Press key 4. Display <sup>[1]</sup>:



4. Move the dancer arm against the spring force to the opposite end position (picture at the top, B) and hold it there. Press button 4.
5. Restart the printer.

<sup>1</sup> Picture shows example value.

# Operation / Malfunction / Cleaning

## INSERTING MATERIAL

The material – depending on the set direction of rotation – is wound around the core in a clockwise or anti-clockwise direction.

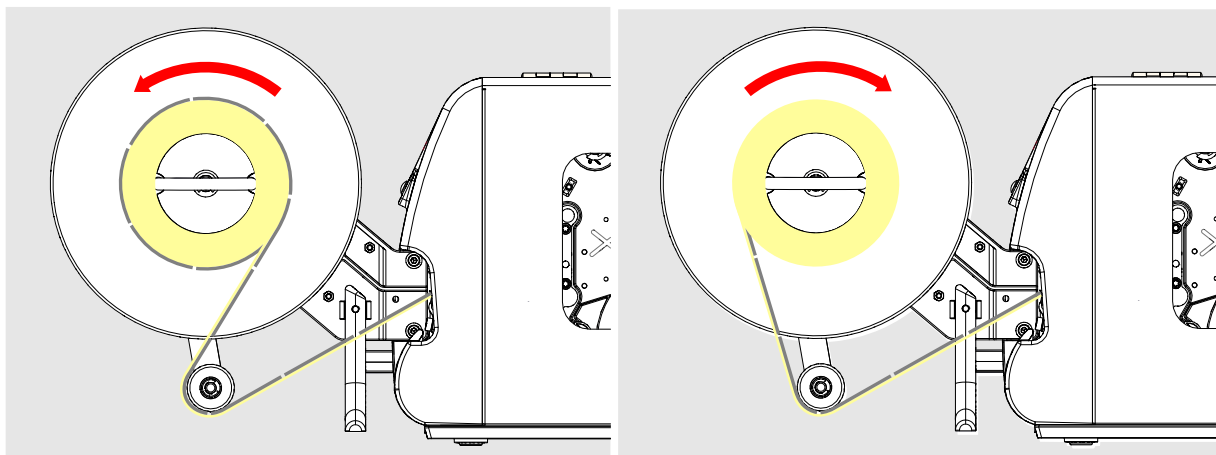
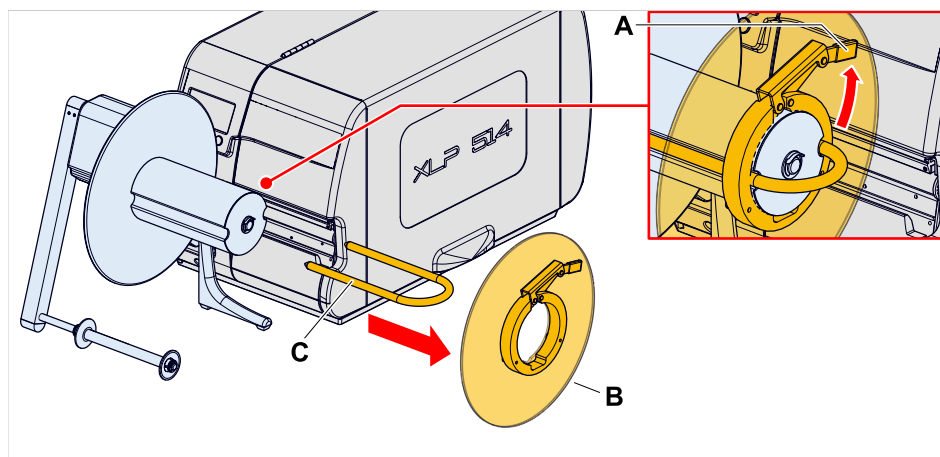

Fig. 5: Left: Rotation direction with labels outside; Right: Rotation direction with labels inside.

### Procedure

1. (If not already done) Open the clamping lever (A) on the guide disc (B). Remove the guide disc and the clamping bracket (C).



2. Feed the end of the material web around dancer arm and winding core according to the winding diagram (picture at the top) and fix it with the clamping bar. To do so, push the clamping bar with *both* ends over the material:

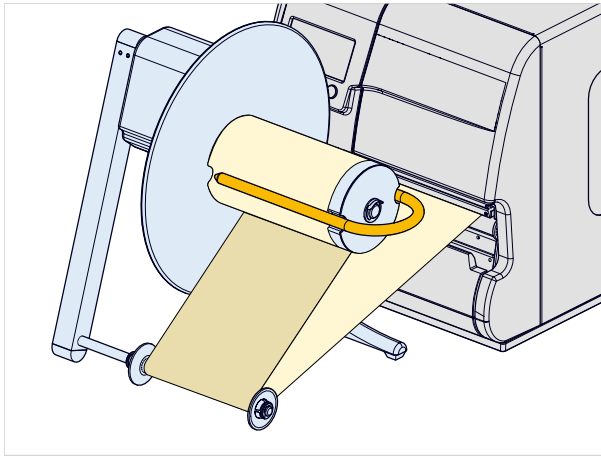

|| If a cardboard core is used: Push the clamping bar *underneath* the cardboard core. ||

3. Remount the guide disk.

|| The recesses at the inner diameter of the guide disk (A) must be positioned over the clamping bar legs (A). ||

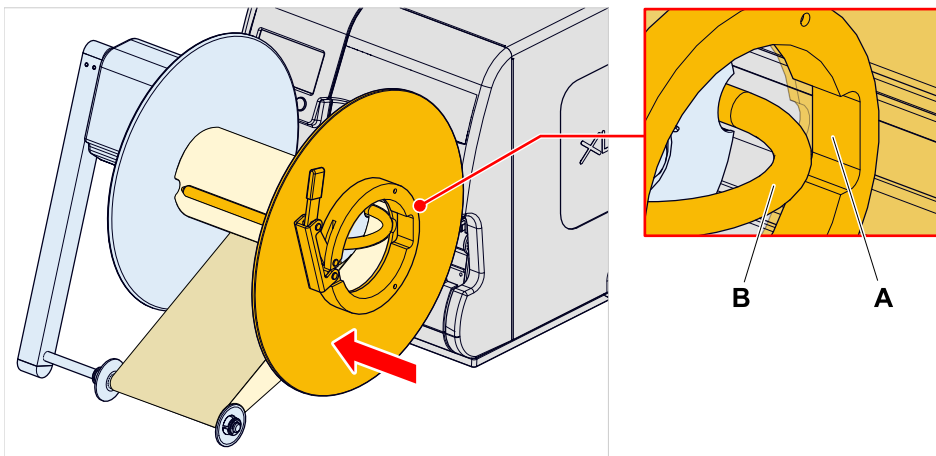

4. Push the guide disk up to the material edge. Close the clamping lever.

|| The guide disk may not wedge in the material. ||



- Adjust the material guides (A) on the dancer arm by pushing them sideways until they correspond to the width of the material.

|| The material should run evenly, and there should be a small gap between it and the material guides. ||

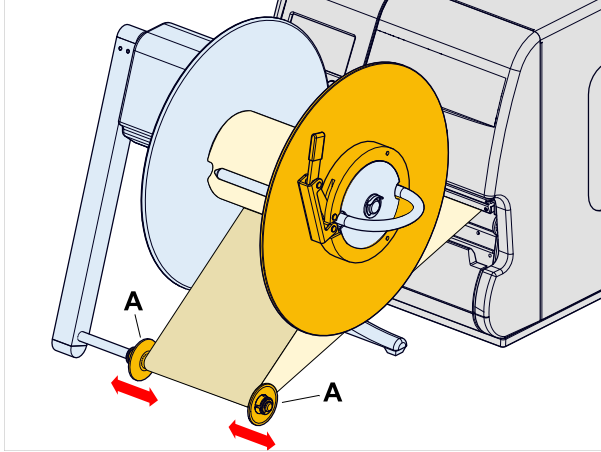

## STARTING/STOPPING

### Before you begin

Printer is switched on and is showing the “Home” screen.

### Procedure

#### Starting:

- Press key 3 (  ).

|| It is essential to let the dancer arm initially reach its final position after starting. Only then, the dancer arm takes control over the rotation speed. ||

The rewinder starts rewinding, until the dancer arm reaches the final position. At that point, the rewinder stops.

- Press key 1 to get to the “Ready” screen.

|| If a printjob has already been loaded, both printing and rewinding start nearly simultaneously. ||

#### Stopping:

- To stop or start again, press key 3 (  ), works on both screens, “Ready” and “Home”.

## TROUBLESHOOTING

### Printer stops rewinder

If the printer stops for some reason, the rewinder stops too.

- ▶ Eliminate the cause of the stopp (if it was unintended).

### Rewinder stops printer

If the dancer arm stays during rewinder operation in the loose position for some seconds (approx. 5), the following error message shows up:

```
Status num:      5004
Rew. mat. tear
```

The printer control assumes that the material is torn off between printer and rewinder.

Printer and rewinder are stopped.

- ▶ Insert material newly and acknowledge the error message.

### Narrow label material is pulled to the inside edge

When narrow label material is used (< 30 mm), problems with the material guiding between printer and rewinder may occur. In this case, the label material is pulled to the inside edge underneath the print head and crumples there.



- ▶ Install the run-in roller for narrow labels.

|| For detailed information refer to the service manual, chapter "Appendix" > "Run-in roller for narrow labels". ||

## CLEANING



#### WARNING!

Rotating shaft!

Danger of hair and clothing being pulled in by unintentional actuation of the rewinder.

- ▶ Switch off the printer and disconnect the power cable before cleaning the unwinder.

- ▶ Remove *dust particles* with a soft brush or a vacuum cleaner.
- ▶ Clean the *housing* with a cloth moistened with a standard commercial neutral cleaner.
- ▶ Remove *glue residues* with a cloth moistened with ethyl alcohol.



Telephone: +49-8165-925-0 | [www.novexx.com](http://www.novexx.com)

**NOVEXX**«  
SOLUTIONS

**Novexx Solutions GmbH**

Ohmstraße 3  
85386 Eching  
Germany