

INSTALLATION MANUAL

ALS/XLS 20x/256/272

Labeler

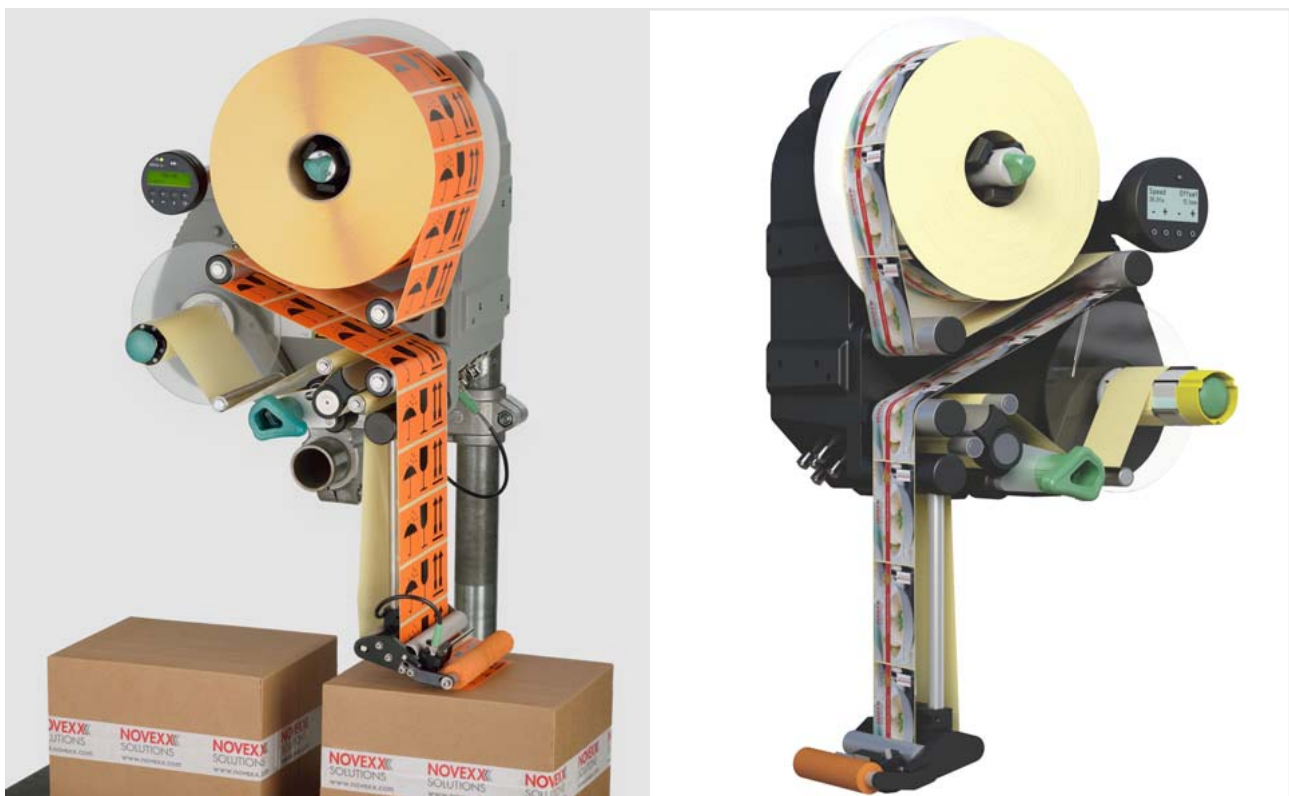

Contents

Please observe the following -7

- General information -7
 - Validity and applicability of this manual -7
 - Conventions and information -8
 - Notes on installation and repair work -9
- Safety instructions -12
 - Information and qualifications -12
 - Machine operating safety -13
 - Safe operation -14

Installation and Deinstallation -16

- Unpacking, assembling and connecting the machine -16
 - Transport -16
 - Unpacking -16
 - Setting up -17
 - Attaching the dispensing edge -21
 - Connecting to the mains power supply -23
 - Rotating the Operation Panel -26
 - Check/adjust the position of the operation panel holder -26
- Connecting the sensors -27
 - Photoelectric label sensor -27
 - Capacitive label sensor -31
 - Changing light/dark switching at the product sensor or the alternative label sensor -37
 - Start (product) sensor -38
 - Photoelectric roll diameter sensor -40
 - Rotary encoder -44
- Installing Options -47
 - Connecting / mounting the external operator panel -47
 - Mounting a splice table -49
 - Mounting/connecting the signal beacon -50
 - Adjustable dispensing edge holder -51
 - Rotatable dispensing edge holder -52
- Decommissioning, Dismantling, Disposal -55
 - Take the machine out of operation -55
 - Dismantling the machine -55
 - Machine disposal -56

Functions -57

- Function menu -57
 - Overview -57
 - Notes on the description of functions -59
 - LABEL SETUP menu -59
 - MACHINE SETUP menu -61
 - INTERFACE PARA menu -69
 - Submenu >EASYPLUGINTERPR -69

- Submenu >COM1 PORT **-69**
- Submenu >NETWORK PARAM. **-70**
- SIGNAL INTERFACE **-72**
- Submenu >PLC SIGNALS **-72**
- Submenu >APPLIC. SIGNALS **-73**
- Submenu >AI BOARD SIGNAL **-76**
- Submenu >AI BOARD SIGNAL **-77**
- Submenu >ACTIVE INPUTS **-77**
- SERVICE/DIAGNOS. menu **-77**
- SERVICE DATA menu **-79**
- Submenu >MODULE FW VERS. **-79**
- Submenu >OPERATION DATA **-80**
- Submenu >POWERSUPPLYDATA **-80**
- Submenu >CPU BOARD DATA **-80**
- Submenu >DISPLAY DATA **-81**
- Submenu > PERIPHERAL DATA **-81**
- Submenu >MEMORY DATA **-82**

Enhanced Functions -83

- Access via a Web/FTP server **-83**
 - Web server **-83**
 - FTP server **-87**
- Saving/loading a configuration **-89**
 - Applications **-89**
 - Saving onto an external memory medium **-89**
 - Loading from an external memory medium **-90**
 - Automatic loading **-91**
 - Loading a configuration via the data interface **-91**
 - Example of a printout from SETUPALL.FOR **-92**

Electronics Description -96

- Signal Interface **-96**
 - General notes **-96**
 - Circuit diagrams for signal inputs **-97**
 - Circuit diagram for signal outputs **-98**
 - Signals for applicator connection **-98**
 - Applicator type <--> Signals **-100**
 - Signal wave forms of applicator signals **-101**
 - Signals for PLC connection **-110**
 - Signal response „Dispense End“ **-111**
 - Impact of the inhibit signal **-113**
- Data interfaces **-116**
 - Overview connector positions **-116**
 - RS 232 **-116**
 - Connection for external operator panel **-116**

USB (device) **-117**

USB (host) **-117**

Ethernet **-117**

Please observe the following

GENERAL INFORMATION

Validity and applicability of this manual

Contents

The present installation manual refers exclusively to the labelers:

- ALS 204, ALS 206, ALS 209, ALS 256, ALS 272
- XLS 204, XLS 206, XLS 209, XLS 256, XLS 272

The manual is to be referred to for correct installation, set-up and adjustment of the labelers.

The complete operating manual for the respective labeler consists of the following parts:

Manual	Target group	Medium	Availability
User manual	Operating personnel	PDF file	NOVEXX Solutions web page: https://www.novexx.com
Installation manual	Service personnel		
Service manual			NOVEXX Solutions Partner Portal: https://partner.novexx.com
Spare parts catalogue			

Technical State

Technical state: 5/2019

Software versions:

- Firmware: 2.76
- Applicator Interface: 1.44

Liability

NOVEXX Solutions assumes no liability for damages resulting from improper adjustments or repairs of the machine. It is assumed that only knowledgeable and appropriately qualified persons are to perform installation, adjustment, or repairs.

Information about the required qualification: see chapter **Information and qualifications** □ on page 12.

Copyright notice

All rights to this operating manual are assigned to NOVEXX Solutions. Transmission, reprinting or any other means of reproduction of this manual, whether whole or in part, are not allowed without prior written permission. Third parties, in particular competitors, are not to be allowed access to information derived from this manual.

Manufacturer

Novexx Solutions GmbH

Ohmstraße 3

D - 85386 Eching

Phone: +49-8165-925-0

www.novexx.com

Conventions and information

Explanation of symbols

In order to facilitate legibility and an overview, the various types of information used herein are categorised and identified with certain symbols.

Sentences that are introduced by an arrow contain procedural instructions.

→ Carry out procedural instructions one after the other in the prescribed order.

The following information is introduced with a dash:

- List items
- Descriptions of conditions
- Description of previous work steps
- Prerequisites for implementing actions described in the following passage

Warnings concerning dangers and risks

Important text passages which must absolutely be followed are particularly marked for special attention:



WARNING!

A warning notice indicates risks which could result in death or serious injury of the personnel! The notice contains safety instructions on how to safeguard possibly affected personnel.

→ The instructions must be followed.

CAUTION!

A caution notice indicates risks which, if unheeded, could lead to material damage or bodily injury (minor injuries). The notice contains instructions on how to prevent damage or injury.

→ The instructions must be followed.

Illustrations

When required, text passages are accompanied by illustrations. The reference to an illustration is indicated by typesetting the [illustration number] in square brackets. Capital letters following an illustration number, e.g. [12A], refer to the corresponding position indicated in the illustration.

Symbols for buttons

- Buttons on the operator panel are represented with symbols, as they can be found *on* (ALS 2xx) respectively *above* (XLS 2xx) the buttons. Although the symbols on the control panels of the two machine series differ slightly, for reasons of clarity only the ALS symbols are used in this manual:

ALS 2xx				
XLS 2xx				

- Where two or more buttons must be pressed at the same time, a "+" appears between the symbols: +

Functions

Functions are printed in grey text, in the form NAME OF MENU > Name of function .

Supplemental information



The information symbol indicates notices and recommendations as well as additional helpful information.



Auxiliary materials:

- Auxiliary materials, e.g. lubricants, glues or cleaning agents



Tightening torques:

- Tightening torques for the listed screw connections

If special tools or other aids are needed for a task:



Tools:

- List of the tools and aids that are required for the following activities

Notes on installation and repair work

General information

Before performing any maintenance or repair work:

- Block access to the working area of the machine to unauthorised persons.
- Post a notification sign, which calls attention to the work.

Electro-static discharge:

- When the casing is open, protect the electronics from damage due to electro-static discharge, e.g. wear an anti-static arm band.

Tools:

- Only use suitable tools.
- Ensure all tools are at hand before beginning the work.
- Do not attempt to improvise or to use improper tools, e.g. loosening an interior-toothed screw (Torx) with a hexagon socket driver.

Rubber and plastic parts:

- Do not allow hoses, seals, and other rubber or plastic parts to come into contact with grease, petrol, benzene, kerosene or mineral oil.

Environmental protection

- Avoid unnecessary waste, e.g. use cleaning cloths sparingly and reuse packing material.
- Only store operating materials, such as fresh or used cleaning agents, in suitable containers. Never allow them to enter the sewerage system or to seep into the ground.
- Do not put old batteries, removed parts, and used cleaning agents in household waste. Dispose of them in an eco-friendly manner.

Packaging materials:

- Only recyclable materials are used for packaging the machine.
- Dispose of unwanted packaging material in an eco-friendly manner.

Eco-friendly disposal:

- Sort the waste as much as possible, e.g. separate metals from plastics.
- Avoid contaminating the waste if possible.
- Drop off the waste at the collection points provided for that purpose or
- Have the waste collected by suitable recycling agencies.
- Use any on-site options.
- Observe all relevant rules, ordinances, and laws.

Rules for electromagnetic compatibility

Connect all metallic parts to each other via large surfaces, ensuring electric conductivity:

- Only polished metal surfaces are electrically conductive. Painted or oxidised surfaces are unsuitable. Aluminium which appears to be polished still has an invisible oxidation layer on the surface.
- Coated or plated surfaces, though electrically conductive, can reach very high resistance values at high frequencies (skin effect).
- Clean contact surfaces, polish the metal, use fan disks (washers) or mounting plates.
- Carry out EMC grounding, preferably as a neutral (star) point. A neutral (star) point prevents loops.

When laying the signal lines and power cable, space them apart:

- Lay all control and signal lines at least 50 cm distant from power cables (e.g. motor line). Minimum distance in the switch cabinet: 20 cm.
- Spatially lay out all the lines in the switch cabinet as close as possible to the reference potential.

Lead the signal lines into the unit or switch cabinet from one side only:

- The more lines that are laid in front and in back between the switch cabinet and the machine, the larger the radiation surface of the radiated electromagnetic energy.
- Lead the signal lines out of the machine (in one bundle and from one location, if possible) and into the switch cabinet.

Twist together unshielded lines from the same circuit:

- This reduces interference effects of various kinds.

Wire inductive components to suitable interference suppressors:

- Possible inductive components: Relay, solenoid valve
- Possible interference suppressors: Diodes, varistors, RC combinations

→ House all components suspected of being sources of RF interference fields in a closed metal casing (Faraday screen).

Shield all signal and control lines:

→ Ground the shielding on both sides at its large surfaces.

→ For insufficient potential equalisation between the shielding lines: Lay an additional equalisation lead parallel to the shielding with a cross section at least 10 mm².

Avoid equalisation currents in the shielding of the signal lines:

- Equalisation currents can arise between subassemblies with different grounding conditions.

→ When the grounding conditions are different, only shield the side with the better grounding condition.

→ Only shield both sides when the grounding conditions are the same (e.g. inside a machine).

Power filter:

→ Mount the power filter direct at the power supply.

→ Connect the filter casing to the EMC grounding via large metal surfaces.

Lay all lines as close as possible to metal parts, even reserve cable:

- Freely hanging lines act as transceiver antennas.

→ Ground all reserve cables and unused wires in the cables at least at one end.

Keep the cables as short as possible:

- Cable resistance and signal distortion increase with the length of the cable.

SAFETY INSTRUCTIONS

Information and qualifications

Ensure necessary qualifications

- Only allow appropriately qualified personnel to set up, adjust, and repair the labeler, e.g. mechanical and electronics specialists.
- Only allow work on the electronics system to be done by authorised electronics technicians.
- Clearly define the responsibilities for installing, setting up, adjusting, and repairing the labeler. Consistently adhere to the responsibilities.

Qualification for system integrators and service technicians („service personnel“)



Knowledge required to install the print dispenser and perform service work must be demonstrated through appropriate qualification. Only service personnel with technical training are able to assess the tasks to be performed and recognise potential dangers.

- Knowledge acquired through technical training in mechanics and electronics (for example in Germany the training to become a mechatronics engineer).
- Participation in a technical training course for the corresponding labeler offered by the manufacturer.
- The service personnel must be acquainted with the functionality of the labeler.
- The system integrator must be acquainted with the functionality of the of the system into which the labeler is being integrated.

Tasks	System integrator	Operator	Service technician
Install the machine	X		
Connect	X		
Make settings	X		
Switch on/off	X	X	X
Insert/change material/ribbon	X	X	X
Application-related settings	X	X	X
Rectify minor operating faults ¹	X	X	X
Clean the machine		X	X
Rectify major operating faults ²			X
Settings to the electronics/ mechanics			X
Repairs			X
Manual:	Service manual	Operating Manual	Service manual, spare parts catalogue

[tab. 1]An example of the distribution of tasks among different qualified personnel

1) For example faults when detecting labels
 2) For example incorrect labelling

Pay attention to the information



WARNING!

Reliable and efficient operation of the labeler is only guaranteed if all necessary information is observed!

- Carry out the installation, connection, programming, setting, and repairing of the machine exclusively in accordance with the specifications in this manual.
- Observe additional safety and warning notices attached to the labeler.
- Observe and adhere to all relevant ordinances and rules in their applicable form¹.

1) Examples: Work place regulation, Accident prevention regulations, Trade union regulations for occupational safety and health, Equipment safety law, Recycling and waste management law

Information must be made available

This service guide

- must be made available to all persons who are entrusted with installing, setting up, adjusting, or repairing the labeler.
- must be maintained in legible condition.
- must be made available to the new owner if the machine is sold.
- Safety and warning notices attached to the labeler must be kept clean and legible. Missing or damaged warning plates are to be replaced.

Machine operating safety

Installation, maintenance



WARNING!

Improper usage of the machine can lead to accidents, material damage and loss of production!

- When installing the labeler, check for visible shipment damage. Immediately inform Novexx Solutions of any damage.
- When installing the machine on a support stand, make sure that it can not tip over.
- Only put the labeler into operation if it is in flawless condition.
- Only perform alterations or conversions to the labeler with the consent of Novexx Solutions's customer service.
- Only use original replacement parts.

Danger of body part trapping and pinching at the dispensing edge due to products moving in the conveyor direction!

- Take appropriate measures to prevent personnel from reaching between a product and the dispensing edge; e.g. install a protective guard or shield.

Before starting up the machine:

- Carry out test runs using the task-specific settings under near production conditions.
- Only put the machine into operation after at least one successful test run has been completed.

Protection measures in applicator mode



WARNING!

Danger of crushing between dispenser edge and applicator pressure plate due to applicator movement!

→ Prevent personnel from reaching between dispensing edge and applicator by installing higher-level protective equipment ¹.

1) Movable, separating guards according to EN 953

After all servicing or repair work



WARNING!

Risk of an accident due to moving or loose parts!

→ Re-install all covers and safety equipment.

→ Check for firm seating of all screw connections that were loosened during the work.

→ Remove all tools and other aids used during service and repair from the working area of the labeler.

→ Verify flawless functioning of all safety equipment.

This unit operates at mains voltage! Coming into contact with electrically live components can cause potentially lethal electrical shocks and burns.

→ After assembling, check the printer according to the regulations relevant in your country.

Safe operation

Protect against injuries that can result from electrical current



WARNING!

Contact with energised components can result in life-endangering currents through the body as well as burns. The labeler is connected with the mains supply!

Only allow work on the electronics system to be done by authorised electronics technicians.

→ Observe the following information unconditionally.

Power connection:

→ If the power switch is not accessible due to the installation position of the machine, a suitable *accessible* separator has to be provided by the system integrator.

The device is *only completely* disconnected from the mains if the power cable is unplugged.

→ Make sure the power supply socket is accessible.

→ In case of emergency, switch off the device and disconnect the power cable.

(ALS/XLS 20x with splash guard) The power cable cannot be pulled off from the machine side power connector .

→ If the machine is connected to a cabinet, a suitable and accessible power separator must be provided by the system integrator.

Before any repair work:

- Detach the machine from power supply.
- Check to ensure it is de-energised.
- Secure the power supply against unintentional or unauthorised switch-on.

Casing:

- Before opening the casing pull the power plug.
- The casing may only be opened by trained personnel and when the machine is de-energised.
- Only put the machine into operation when the rear wall of the casing is correctly in place.

If the machine must be switched on while the casing is open for repair or inspection:

- Never touch energised components. This also applies to components with low voltages.

Ensure the flawless condition of the electrical system:

- Regularly check the electrical equipment.
- Only connect the machine to other machines if these meet the requirements for a SELV circuit, in accordance with EN 60950.
- Re-tighten loose connections.
- Immediately replace damaged lines.
- After assembling, check the printer according to the regulations relevant in your country.

Protection against injuries that can result from mechanical actions



WARNING!

Acute risk of injury and long-term bodily injury from working with heavy loads!

- Lift or carry the machine with a minimum of 2 persons. If possible, use a crane or other lifting device.
- Only use suitable and defect-free restraining devices during transportation and installation.
- Never allow the machine to stand with loosened mounting brackets, not even for a short time.
- If the machine is fastened to a movable support: Ensure it can not tip over.

Risk of accident due to uncontrolled machine start-up!

- Before doing any repair work, switch off the machine and pull the power plug.

Installation and Deinstallation

UNPACKING, ASSEMBLING AND CONNECTING THE MACHINE

Transport

CAUTION!

To avoid damaging the machine during transport:

- Only transport the machine in its original packaging.
- Keep the original packaging for a later transport.

Unpacking



WARNING!

Acute risk of injury and long-term bodily injury from working with heavy loads!

- Lift or carry the machine with a minimum of 2 persons. If possible, use a crane or other lifting device.

CAUTION!

To avoid damaging the machine during unpacking:

- Never hold the machine by the deflection rollers, dancer arm or rewind or unwind unit.

- Lift the machine out of the packaging with at least two persons.
- To do so, hold the machine by its casing.
- After unpacking, check the machine for visible shipment damage.



Alternatively, the machine can be lifted with a crane.

- To do so, screw an eye ring M10 into the location shown in [2A].

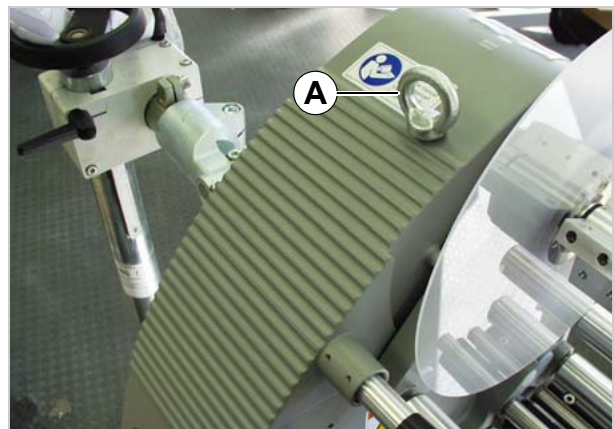

[2] Attachment of an eye ring M10 (A) for transportation with a crane.

Setting up



WARNING!

Risk of injury from a tipping over support stand.

- When installing the machine on a support stand, make sure that it can not tip over.
- Fix the support stand onto the ground.

Prerequisites:

Support stand with a tube end providing the following measures:

- Outer diameter: 60 mm
- Wall thickness: minimum 5 mm

The machines offer three attachment points for mounting to the support:

– *Rear side*

Requires a fixing bolt to be mounted on the rear side of the machine. A joint [3B] is used to attach the fixing bolt to the support. Advantage: The machine can be inclined both side to side and forwards and backwards.

– *Side plate*

Requires a flange [3A] to be mounted on the side wall of the machine.

– *Base plate*

Requires a flange [3C] to be mounted on the base of the machine casing.

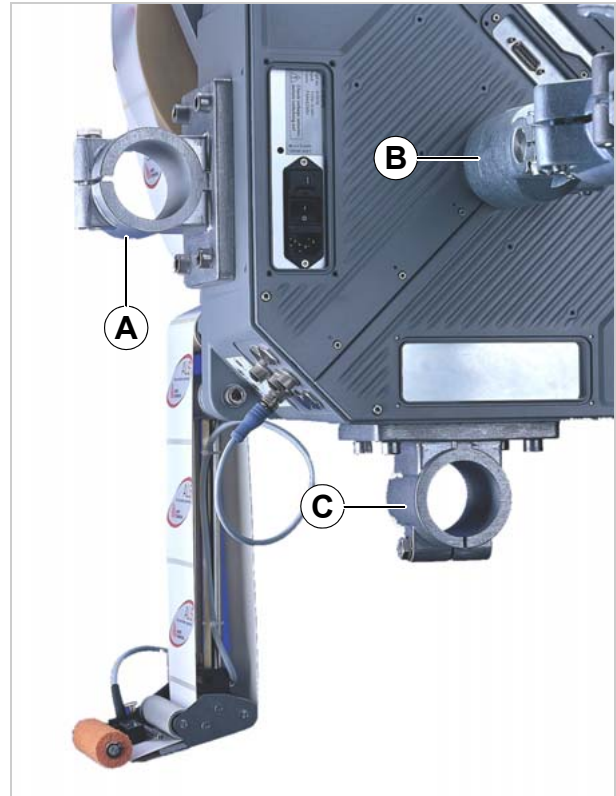

[3] Attachment points

For machines held from the rear side

- Order number for *fixing bolt assembly* [4A] (including screw and cylinder pins): A7621

 Tools:

- 17 mm hexagon socket driver
- 8 and 10 mm hexagon socket drivers

- Locate the two cylinder pins [4B] in the holes in the fixing bolt [4A].

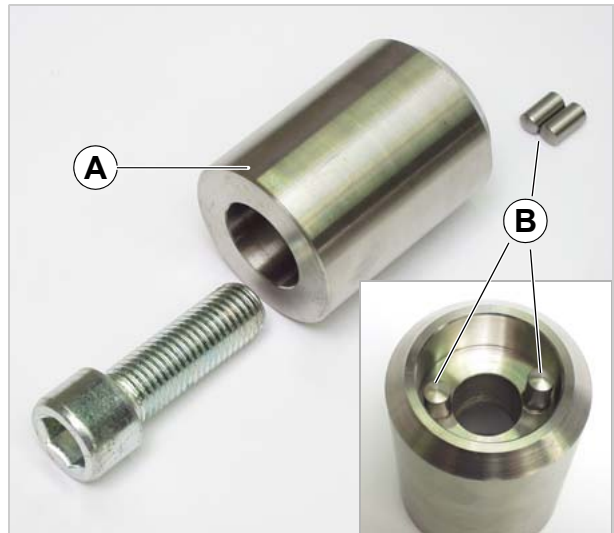

[4] Fixing bolt (A) for clamping the machine from the rear side. The cylinder pins (B) prevent rotation of the fixing bolt.

- Screw the fixing bolt [5B] onto the flange on the rear side of the machine with the screw provided [5C].
- The two cylinder pins must locate into the holes [5A] in the flange.
- Mount the fixing bolt with its bevelled side pointing inwards towards the machine.

 Tightening torque: 350 Nm

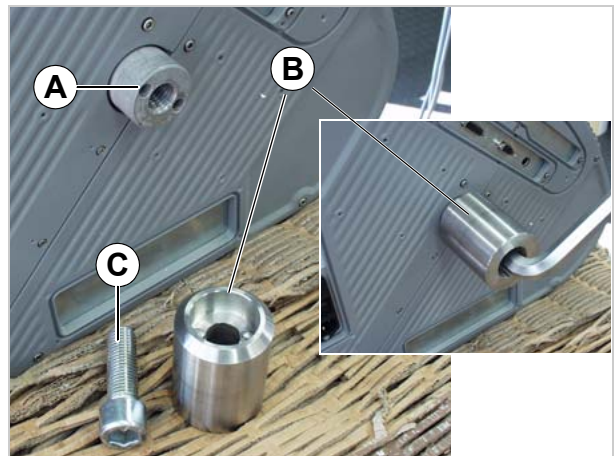

[5] Mounting the fixing bolt (B).



WARNING!

Danger of injury by the machine falling to ground.

This danger exists if the machine is to be mounted so as enable sideways swivelling, i.e. if the pin in the joint is vertical. If the machine is mounted incorrectly [7], it will fall to the ground as soon as the set screws clamping either the top or bottom half of the joint pin are loosened.

→ Always mount the head joint assembly to the machine with the clamp pointing downwards [6].

→ Wear safety footwear during mounting.

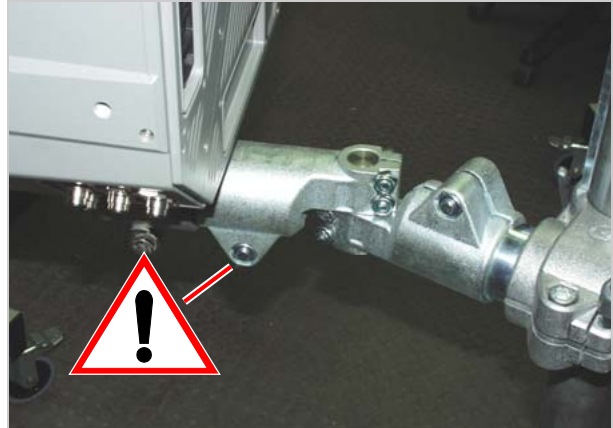

[6] Correctly mounted head joint assembly. The clamp on the machine-side of the joint is pointing *downwards!*

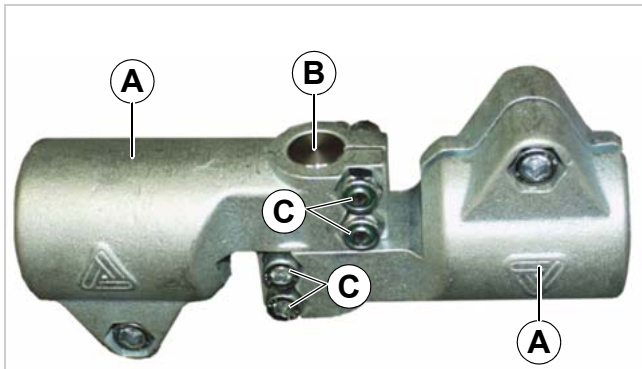

[8] A Head joint element
B Joint axis

→ Assemble the two halves of the head joint [9A] with the joint pin [9B] as shown. Tighten the set-screws at the joint axis.

→ Slide one half of joint over the trunnion (bolt-on cylinder) on the machine and tighten the screw [9A].

– Observe the warning notice (see above). Mount the head joint assembly with the clamp pointing sideways or downwards.

→ Lift the machine and slide the free end of the head joint over the end of the support tubing. Tighten the set-screw [9B].



Tightening torques:

- Set-screws at machine and stand [9A, B] 45 Nm
- Set-screws at the joint axis [8C] 45 Nm



[7] Wrongly mounted head joint assembly. The clamp on the machine-side of the joint is pointing upwards!

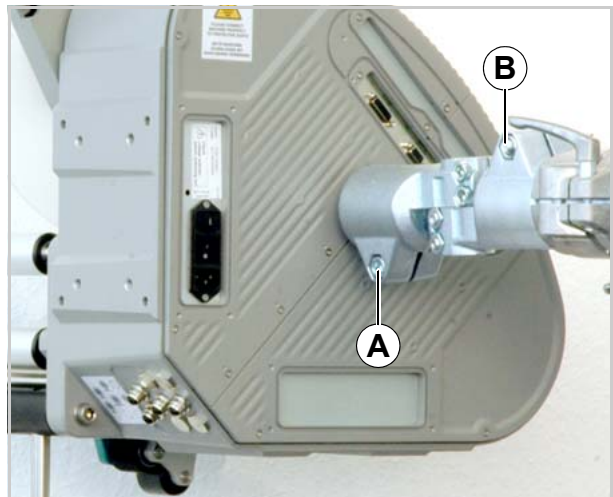

[9] Assembling the two halves of the head joint (A) with the joint pin (B).

Holding machine in place by side plate or base plate

- Order number for *flange plate assembly* [10C] (including screws and washers): A7622

 Tool:

- 8 mm hexagon socket driver

→ Screw the flange plate [10C] to the side or base of the machine.

- Use the four screws provided in delivery (ISO 4762 (DIN 912) M10x25).

→ Lift the machine and slide the clamp over the end of the tubing of the support. Tighten the set-screw [10A].

 Tightening torque:

- Nm - set-screw [10A] 45 Nm



Blind hole depth: 13 mm

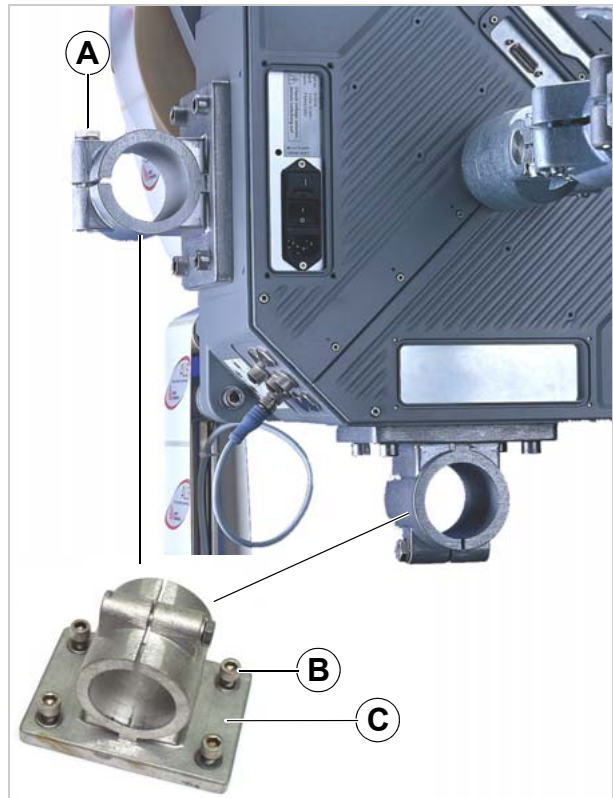

[10] Attachment points

Attaching the dispensing edge

L-shaped dispensing edge

-  Tools:
- 8 mm hexagon socket driver

Both the dispensing edge holder [11D] and the mounting flange on the machine casing have two concentric rings of holes [11B] on the connecting surfaces. Two pins [11C] that fit into these holes are provided with the dispensing edge holder. To secure the dispensing edge holder so it cannot swivel, the pins are located in diametrically opposite holes. By replacing the pins in adjacent holes, the mounting angle of the dispensing edge holder can be adjusted in 15° increments.

CAUTION!

If the machine is operated with the dispensing edge holder rotated to the front, the material web is dragged around the crossbar of the dispensing edge holder.

This can decrease the labelling accuracy and cause error messages („No gap found“).

→ Use a rotatable dispensing edge holder (see chapter „Installing Options“ > „Rotatable dispensing edge holder“).

Assembly:

- Locate the pins [11C] in diametrically opposite holes.
- Choose either inner or outer circle of holes, dependent on angle required.
- Fit the dispensing edge holder [11D] onto the pins at the required angle.
- Fix the dispensing edge holder in place with screw [11A].

-  Tightening torque: 45 Nm

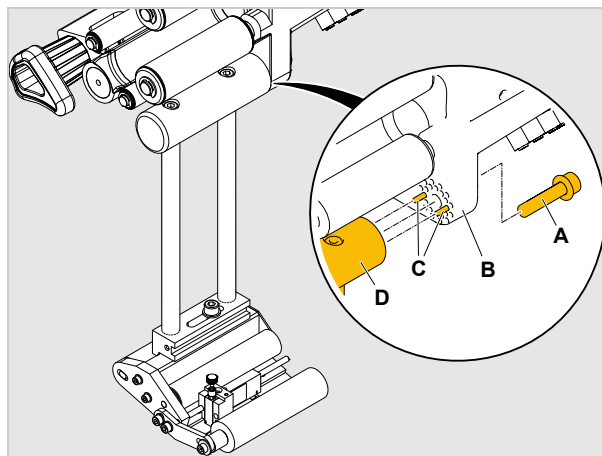

[11] Installing the dispensing edge holder.

V-shaped dispensing edge

-  Tool:
– 8 mm hexagon socket driver

- Mount V-shaped dispensing edge as shown
– The angle of the V-shaped dispensing edge cannot be changed. It is mounted without fixing pins.

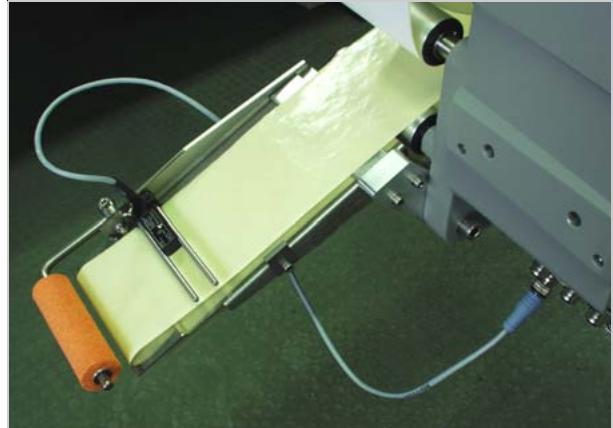

[12] V-shaped dispensing edge in place.

Connecting to the mains power supply

**WARNING!**

The machine is connected with the mains supply! Contact with energised components can result in life-endangering currents through the body as well as burns.

→ Ensure that the machine is switched off before connecting power cable.

→ (ALS 20x / XLS 20x (A)) Only operate the machine at the mains voltage rating set at the voltage selection switch.

→ (ALS 20x / XLS 20x (A)) Ensure that the machine is correctly adjusted to your local supply voltage.

→ (ALS/XLS 256 // ALS/XLS 272 // XLS 20x (B)) Only operate the machine using the system voltage indicated on the nameplate.

→ Only plug machine in to a correctly installed socket with an earth contact.

→ The length of the power cable must not exceed 3m.

Only by disconnecting the plug from the mains supply is the machine *fully* disconnected from the supply. Therefore:

→ Keep mains connection freely accessible.

→ In case of danger switch off the machine and unplug the power cable.



[13] Power supply connection (A) at the ALS 20x / XLS 20x (A) (picture: ALS 20x RH).

Checking the supply voltage setting

i ALS/XLS 256 // ALS/XLS 272 // XLS 20x (B): A power supply setting is not required.

ALS 20x // XLS 20x (A): the labellers are designed for use with a supply voltage of 230 V (AC) or 110 V (AC).

→ Check whether the voltage set matches your local supply voltage.

Switch position	Permitted mains supply voltage
115	100-120 V (AC)
230	200-240 V (AC)

[Tab. 1] Permitted mains supply voltages for the two positions of the voltage selection switch.

To change the voltage setting:

- Ensure that the mains power supply lead is unplugged.
- Slide the switch [15A] into its other position.
- To do this, insert a small screwdriver into the groove [15B] and push the red insert horizontally until it stops in the opposite position (for case shown in fig. [15], to the left).

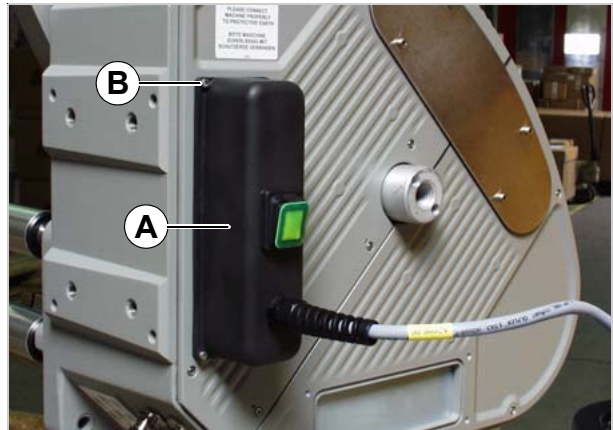

[14] Machine with splash guard (A).

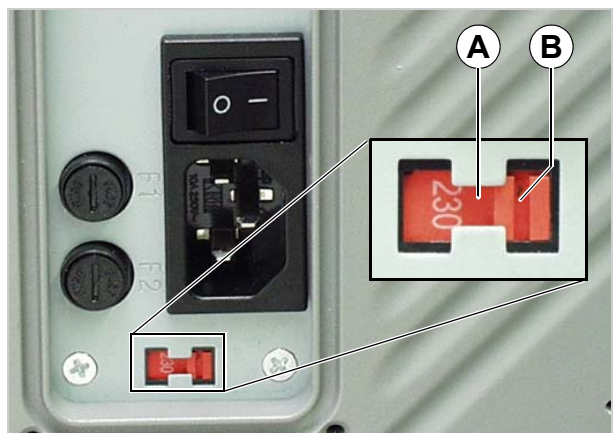

[15] Voltage selection switch at the ALS 20x // XLS 20x (A) (setting shown in picture: 230 V)

Plugging in the power lead

- Ensure that the power switch [16A] is set to "O" (off).
- Using the power supply cable provided, connect the machine to a mains supply socket.

ALS 20x // XLS 20x (A) with splash guard: The power supply cable is connected by installing the splash guard.

- Before installing the splash guard [17A], ensure that...
 - the machine side power switch [16A] is switched on (position „I“).
 - the power switch at the splash guard [17B] is switched off (switch doesn't light).

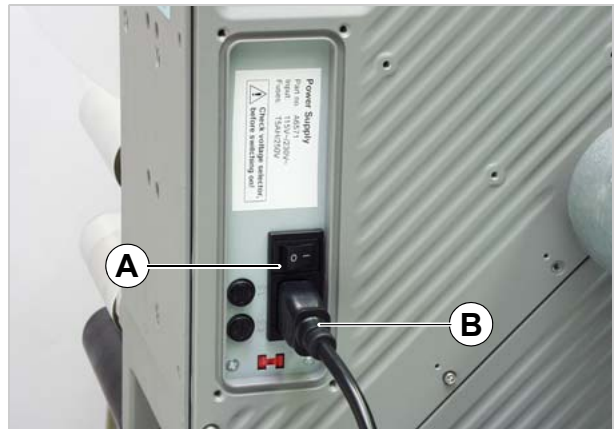

[16] Power lead (B) plugged in (ALS 20x // XLS 20x (A)).

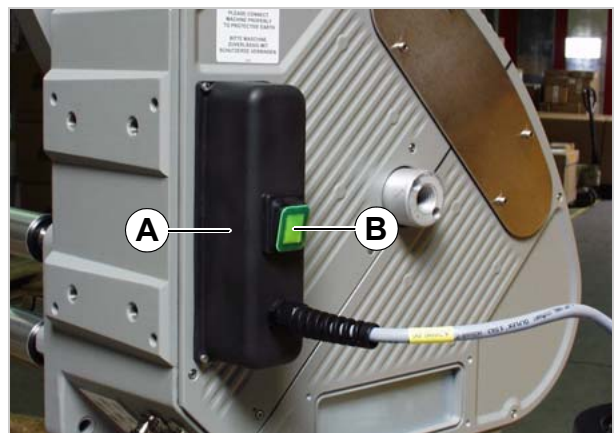

[17] Machine with splash guard.

Rotating the Operation Panel

To adjust the position of the control panel to the mounting position of the machine, it can be rotated by approx. 350° [18]. A stop prevents multiple rotation and thus damage to the cable.

The display of the XLS 2xx is larger compared to the ALS 2xx. In addition, it is eccentrically arranged so that it can be rotated so that it does not get in the way of the material roll..

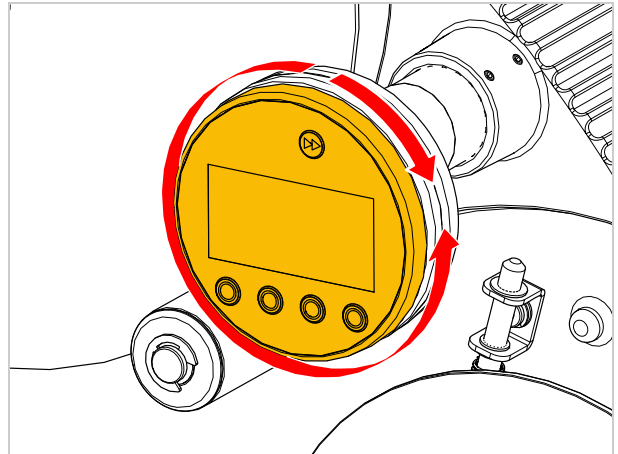

[18] The operation panel can be rotated by approx. 350° (fig.: XLS 2xx).

Check/adjust the position of the operation panel holder

The operation panel must not touch either the 300 mm material roll or the optional guide disc. [19A].

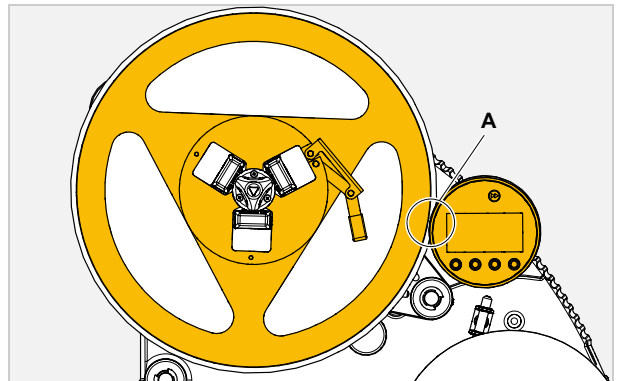

[19] Correct position of the operation panel on the XLS 2xx - The operation panel does not touch the additional guide disc in pos. A.

However, if it should come into contact, the operation panel holder must be turned to the correct position:

- Pull off the operation panel (3 snap-on catches).
- Loosen the 2 set screws [20A] on the base of the operation panel holder.
- Turn the operation panel holder with the nose [20B] to the right (at XLS 2xx RH to the left).
- Tighten the set screws.
- Snap-on the operation panel.

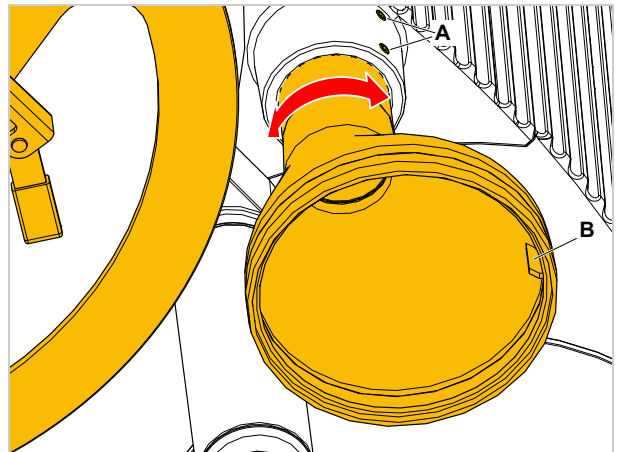

[20] Rotate the operation panel holder with the nose (B) to the right (XLS 2xx LH).

Connection diagram

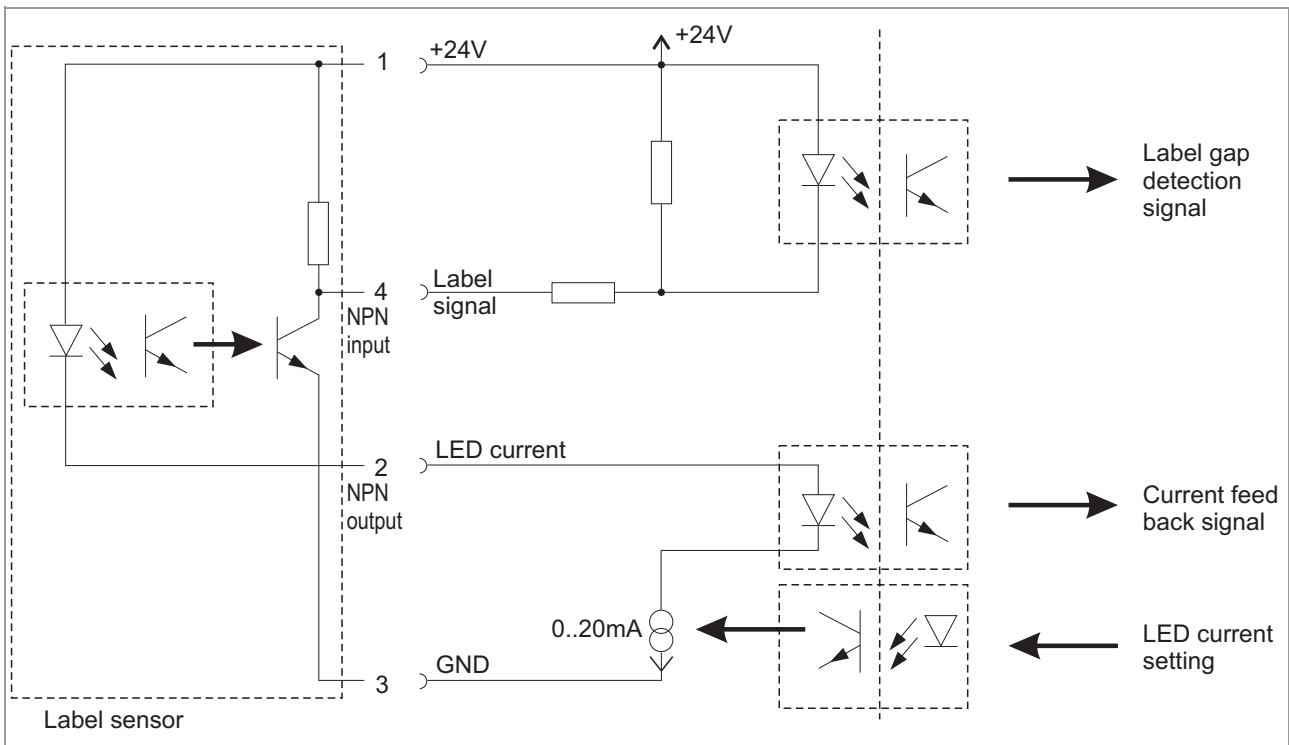

[23] Connection diagram for photoelectric label sensor

i The LED current at pin 2 controls the sensitivity of the sensor.

Teaching the sensor

- Press the button [24A] for 2 s, until the status LEDs [24B] light permanently.
- *Notice:* Don't press the button for longer than 5 s, otherwise you risk to switch between NO/NC¹, see chapter **Switching the Novexx sensor - NC/NO** on page 30.
- After releasing the button, a teaching „time window“ opens for 2-8 s. During this period, the status LEDs are flashing fast [25].
- While the LEDs are flashing, move as many label gaps as possible (at least 2) through the sensor fork.
- The movement direction of the label gap is irrelevant, that is the same label gap may be moved back and forth several times.
- The label gaps have to be moved *manually, not* by pressing the  button.
- If the label gaps were detected successfully, the status LEDs are flashing 2x [26].
- If the label gaps were not detected ideal, the status LEDs are flashing 4x.
- Repeat the procedure, if the label gaps were not detected ideal.

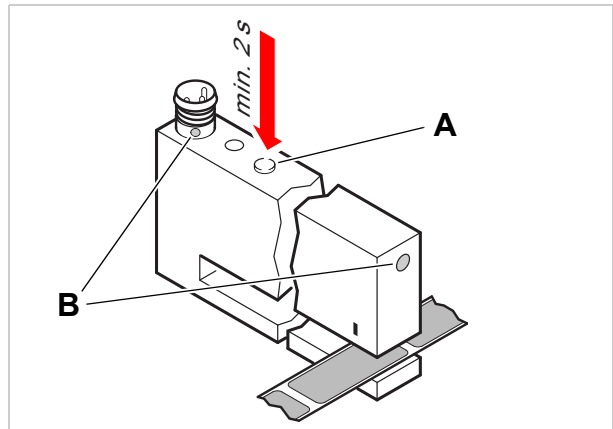

[24] Starting the autoteaching.

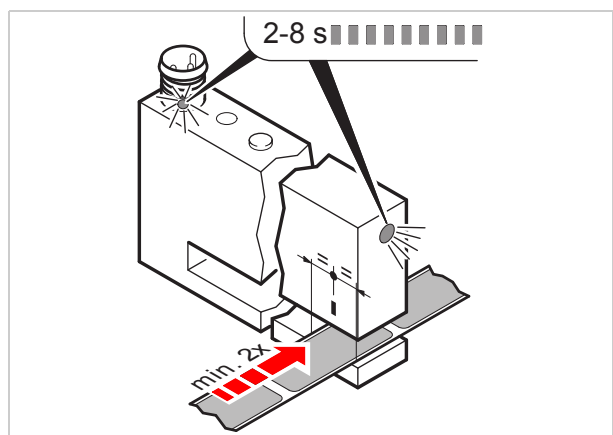

[25] Autoteaching is indicated by flashing LEDs.

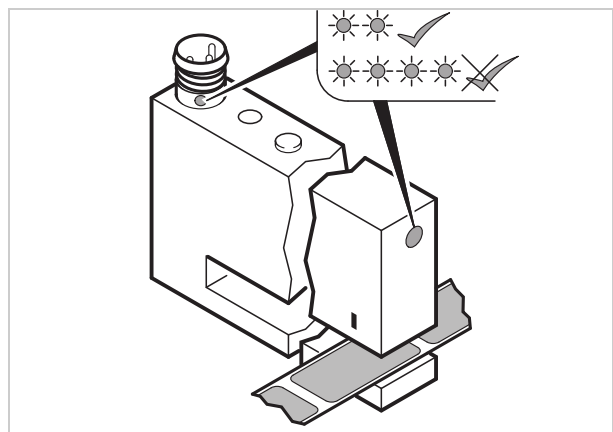

[26] Sensor is successfully set = flashing 2x.

1. NO = Normally open; NC = Normally closed (default setting)

Switching the Novexx sensor - NC/NO

This light sensor is equipped with a push-pull output stage, thus, the two states are called NO (normally open) and NC (normally closed).

Default setting: NC

Switching between NC/NO:

→ Press the button [27A] for at least 6 s, until the status LEDs [27B] flash 2x.

Finding out the current setting:

→ Move some label material through the sensor fork and watch the LEDs.

→ Compare the result with the table:

Mode	Label	LED	Output
Wenglor (NPN)	Yes	On	Low
	No	Off	High
Novexx (NO)	Yes	On	High
	No	Off	Low
Novexx (NC)	Yes	Off	Low
	No	On	High

[Tab. 3] Overview: LED activity and output levels with or without Label.

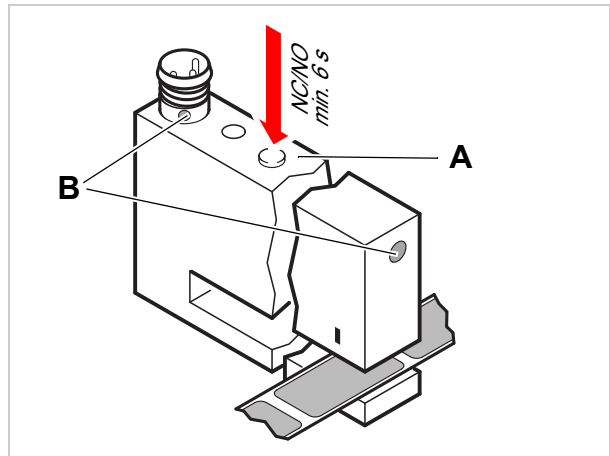

[27] Switching the Novexx sensor between NC and NO.

Capacitive label sensor

Capacitive label sensors are required to detect transparent labels, what is not possible with normal light sensors.

- Permitted sensor types: PNP or NPN
- Default setting: PNP

i Alternative label sensor and standard photoelectric sensor may both be connected at the same time. Selection of the active sensor is done by calling the function MACHINE SETUP > Label sens. type. The setting is stored within the product profile.

NOVEXX Solutions offers a capacitive label sensors from di-soric (www.di-soric.de).

Article numbers:

- N104308 *Capacitive sensor* di-soric KGUTI50 0.4-G3-T4 [28]
- *Sensor kit* (sensor + sensor holder + connection cable) [29]:
A7775 for 160 mm wide dispensing edge holder
A9995 for 230 mm wide dispensing edge holder
- *Sensor holder*
A6059 for 160 mm wide dispensing edge holder
A5574 for 230 mm wide dispensing edge holder
- N100456 *Retrofit kit* (sensor with adapter plate matching the sensor holder + connection cable) [30]. Application: Replacement part for older, no longer available sensor type.

Hold down roller [20] for the use of a capacitive sensor at a machine with the dispensing edge holder rotated to the front.

- N100704 Roller kit 4" roller width
- N100706 Roller kit 6" roller width
- N100711 Roller kit 9" roller width

See chapter **Rotatable dispensing edge holder** on page 52.



[28] Capacitive label sensor from di-soric KGUTI50 0.4-G3-T4

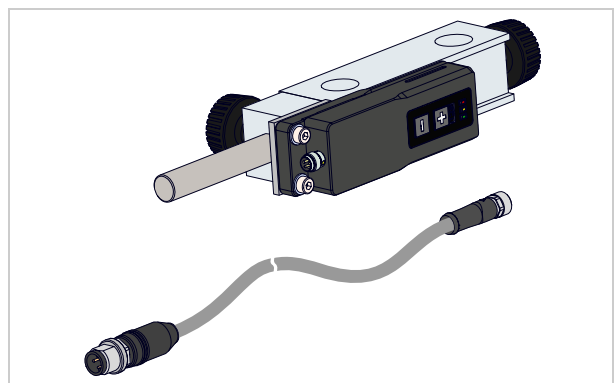

[29] Sensor kit.

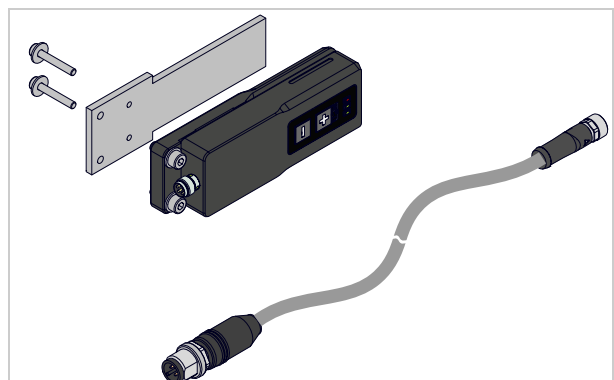

[30] Retrofit kit (replacement for older, no longer available sensor type).

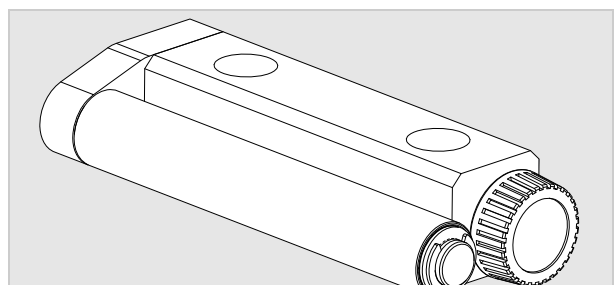

Installation

Tools:

- Hexagon socket drivers 4/6 mm

- Turn out screw [32C] and remove the dispensing edge [32E].
- Remove the screws [32F] from the bottom ends of the holding rods. Take off the dispensing edge holder [32D].
- (Only with rotated dispensing edge holder) Push the hold down roller [32G] onto the holding rods and fix it with the thumb screw [32H].
- Push the sensor holder [32A] onto the holding rods and fix it with the thumb screw [32B].
- Reinstall dispensing edge holder and dispensing edge.

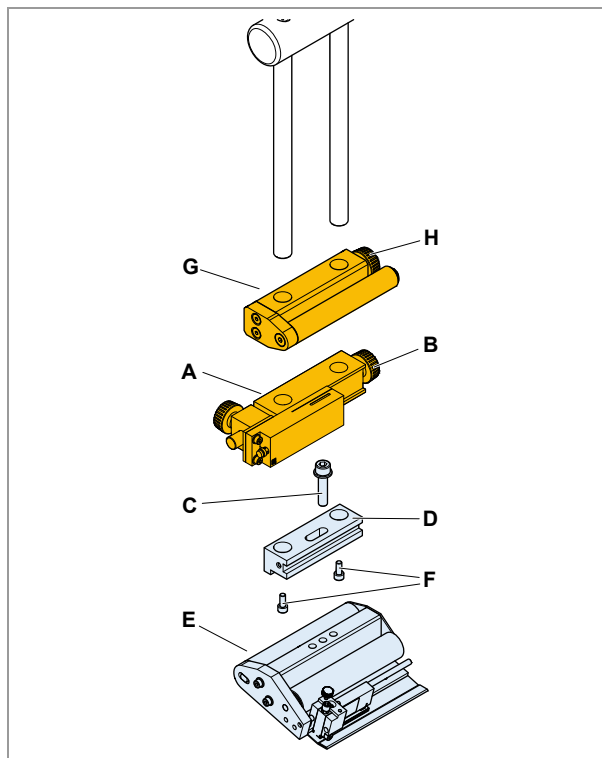

[32] Installing the capacitive label sensor (A).

Installing the retrofit kit

- Screw the sensor to the sensorholder [33].
- Connect the cable.

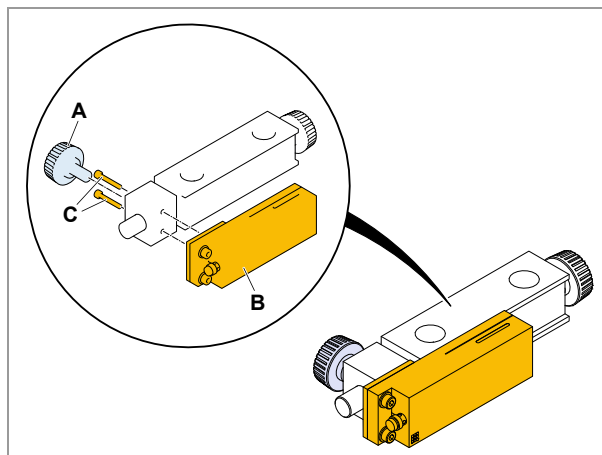

[33] Attaching the retrofit kit to the sensor holder.

Positioning the sensor holder

The sensor holder be varied in a wide range on the holding rods. The most favorable position can be found as follows:

- Label web is in stop position (position just after dispensing a label).
- Loosen the thumb screw [34B] at the sensor holder.
- Push the sensor holder over a label gap.
- Tighten the thumb screw.
- In this position should be possibly few labels between dispensing edge and (capacitive) sensor.

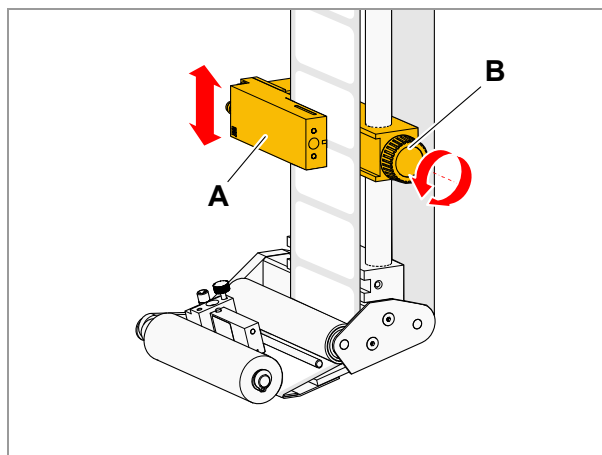

[34] Positioning the sensor holder.

- Fine adjustment of the stop position is done in the same way as with the standard label sensor.

Positioning the hold down roller [35A] (at machines with the dispensing edge holder rotated to the front):

- Loosen the thumb screw at the holder of the hold down roller.
- Push the hold down roller approx. to the middle between the top crossbar [35B] of the dispensing edge holder and the capacitive sensor [35C].
- Tighten the thumb screw.

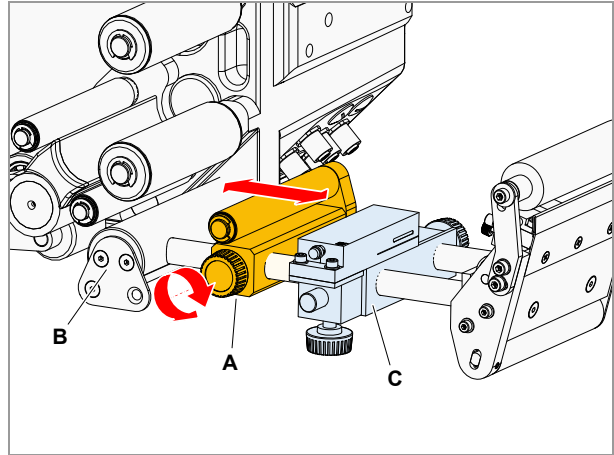

[35] Positioning the hold down roller.

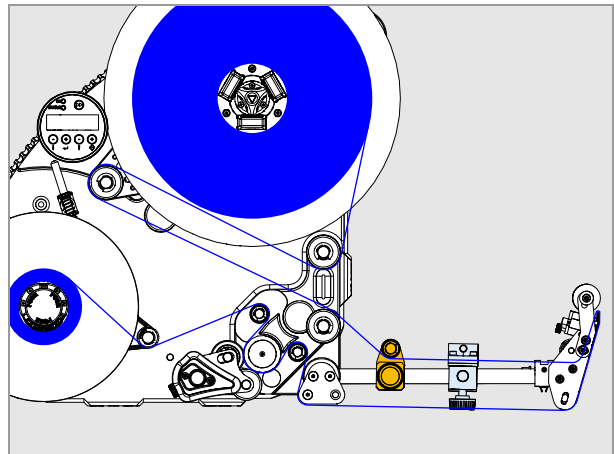

[36] Material path at the dispensing edge holder rotated to the front and using a capacitive label sensor.

Connecting the sensor

→ Plug the sensor to the connector [37A], [38A], [39A] or [40A] depending on the machine type.

Connection accessories	Article no.
Connector	A8142
Connecting cable (coupling-plug)	A7127

Pin assignment

Pin	Assignment
1	+24 V
2	+24 V or ground or no connection ¹⁾
3	Ground
4	Sensor signal

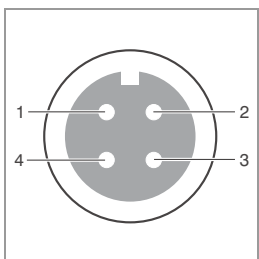

1) Changing light/dark switching at the product sensor or the alternative label sensor  on page 37

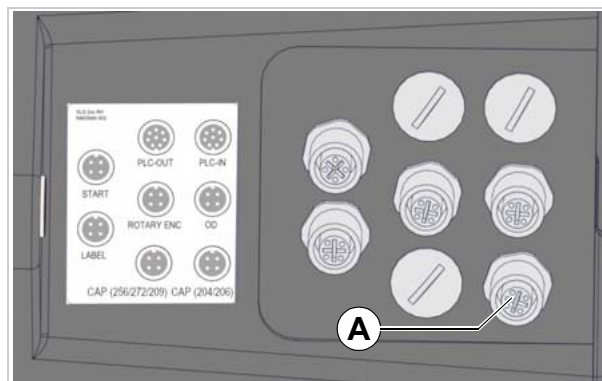

[37] Connection for alternative label sensor (A) at ALS/XLS 204/206 RH.

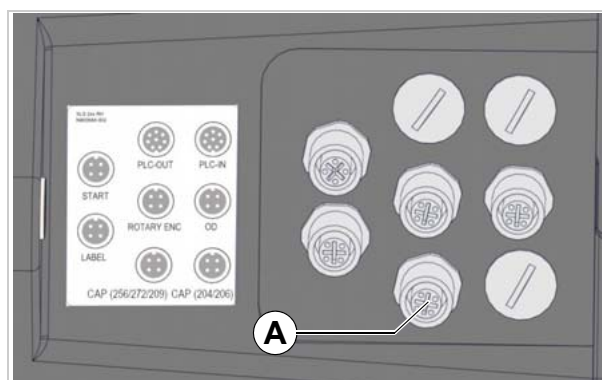

[38] Connection for alternative label sensor (A) at ALS/XLS 256/272/209 RH

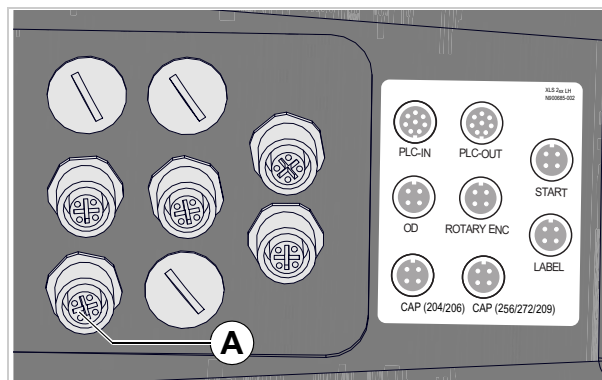

[39] Connection for alternative label sensor (A) at ALS/XLS 204/206 LH.

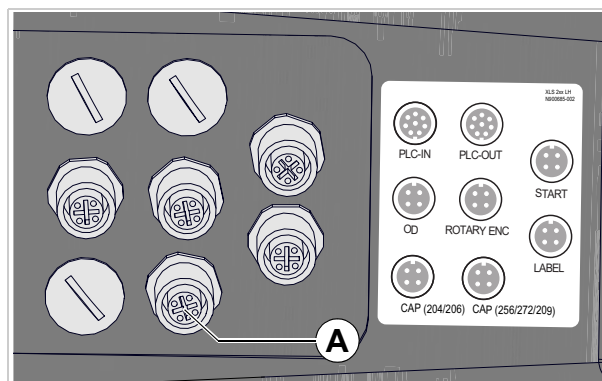

[40] Connection for alternative label sensor (A) at ALS/XLS 256/272/209 LH

Connection Diagram

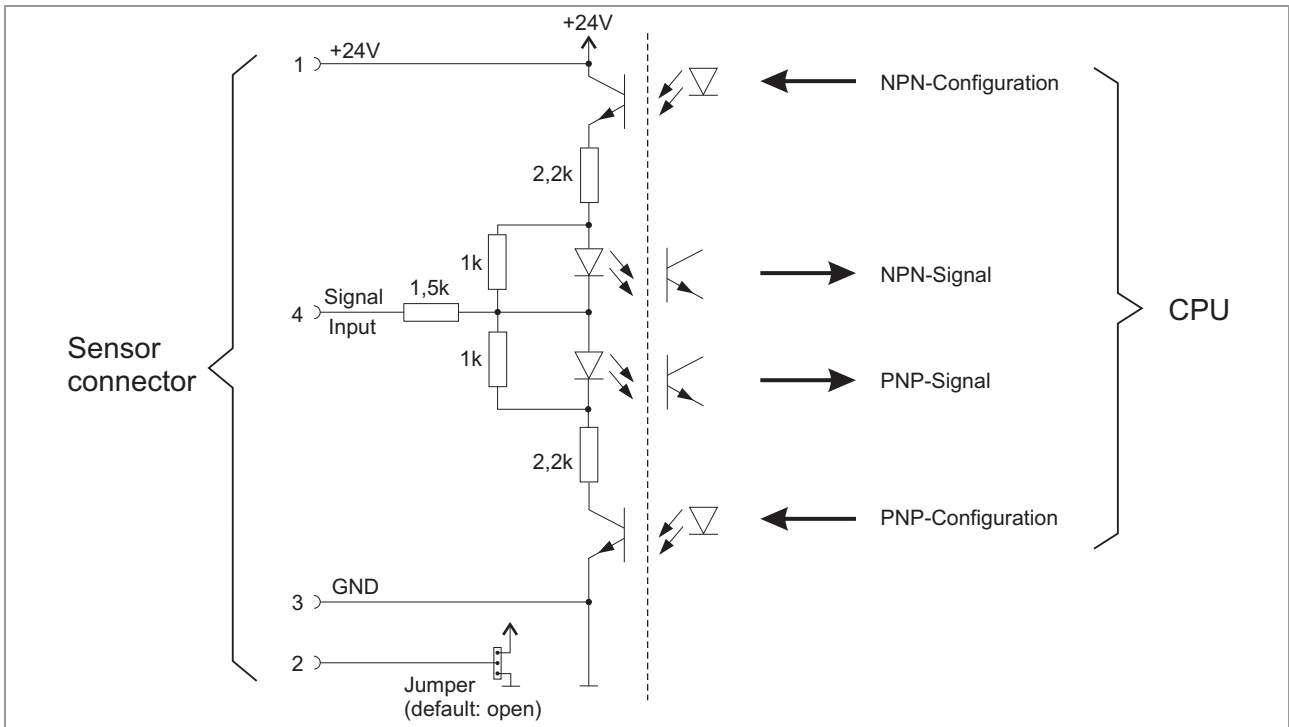

[41] Connection diagram alternative label sensor. Jumper description see [Changing light/dark switching at the product sensor or the alternative label sensor](#) on page 37.

Teaching the sensor

Autoteach:

During the "Autoteach" process, feed at least three labels and label gaps through the fork opening of the sensor. The label web must be taut and rest lightly on the lower leg of the fork opening. Tip: move the sensor up and down on the holding rods with the holder released [42].

- Press the „+“ button [42B] for 2-4 seconds.
- The yellow LED [42C] lights up; it flashes quickly when the button is released.
- Slide the sensor over the label web over some labels and gaps.
- (Alternatively) Pull the label web through the sensor. The „Autoteach“ process ends automatically after a few seconds and the yellow LED stops flashing.

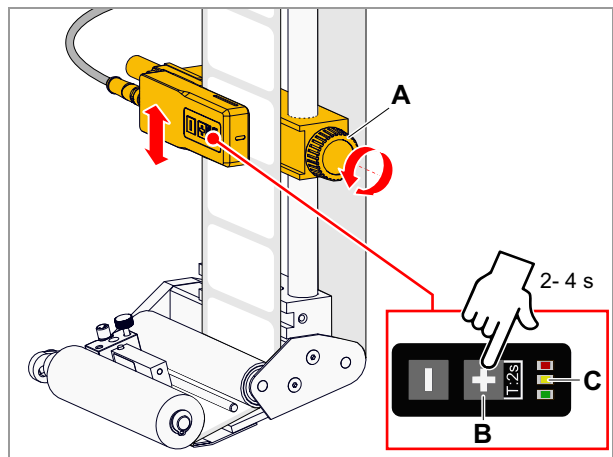

[42] Performing "Autoteach".

Display result:

- Teach process successful: yellow LED flashes twice
- Teach process not successful: yellow LED flashes 4x and red LED lights up

Static „single value teach“ on label gap:

- Position the sensor with the detection area over a label gap and fix it there.
- It is best to remove a label and slide the sensor over the resulting gap.
- Press the „+“ button for 4-6 seconds.
- The yellow LED remains off.

Display result:

- Teach process successful: yellow LED flashes twice
- Teach process not successful: yellow LED flashes 4x and red LED lights up



For more information, see the documentation supplied by the manufacturer.

Setting older sensor types: see chapter **Teaching older labels sensor types** on page 317.

Cleaning the sensor

Due to the small gap between the upper and lower part, adhesive residue from label webs can accumulate in the area of the fork opening.

Tools:

- Hex socket screwdriver 3 mm
- Torx screwdriver Tx20

Cleaning the sensor fork (intensively):

- Disconnect the sensor.
- Unscrew the sensor [43A] from the bracket. To do this, unscrew the two screws [43B].
- Loosen the screw connection of the upper and lower part [44B]. To do this, unscrew the 4 screws [44A].
- Remove adhesive residue with a soft cloth.
- Screw the upper and lower sections back together.
- Tighten screws evenly to avoid mechanical stresses.
- Screw the sensor back onto the bracket.
- Reconnect the cable.
- Perform reference value adjustment. To do this, press the „-“ button for at least 6 seconds.
- Teach the sensor to the label material.

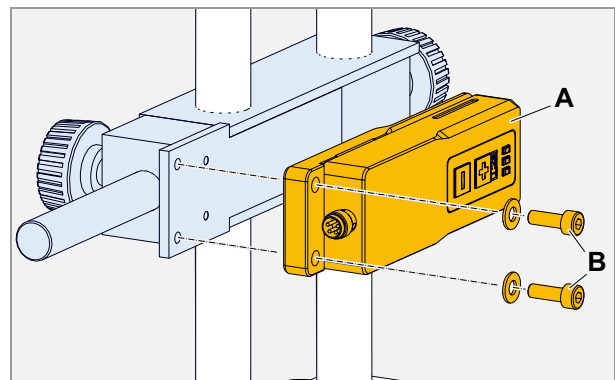

[43] Unscrew the sensor (A) from the bracket.

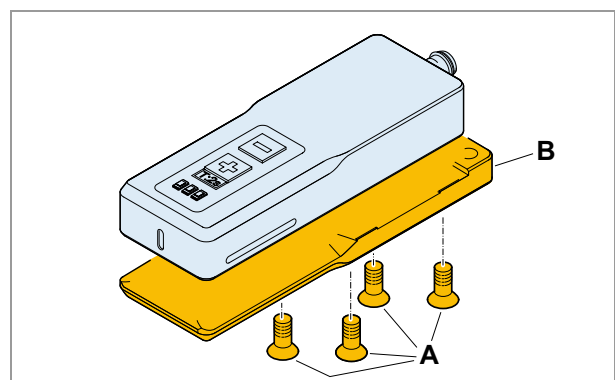

[44] Dismantling the upper and lower part of the sensor.

Changing light/dark switching at the product sensor or the alternative label sensor

- i** Basically, sensors can be assigned to three different groups regarding the function of pin 2:
- a) Pin 2 has no function
 - b) Pin 2 = input, e.g. for light/dark switching
 - c) Pin 2 = output, e.g. for an inverse signal

With sensors or type b), the basic switching type can be changed by connecting pin 2 to +24 V or to ground. For all other sensor types is the absolute rule: Leave the relevant jumpers open!

Example:

The capacitive label sensor offered by NOVEXX Solutions is of type b); Therefore, JP 901 must be left open.

CPU board „Gen. 1“

JP 901 JP 902	Function
	1 Pin 2 of the sensor connector is not connected (default setting)
	1 Pin 2 of the sensor connector is connected to +24 V
	1 Pin 2 of the sensor connector is connected to ground

[Tab. 4] Controlling pin2 at the sensor connector by placing JP901 resp. JP902

1) With the board in the pictured position [45]

CPU board „Gen. 2“

JP 2601 JP 2602	Function
	1 Pin 2 of the sensor connector is not connected (default setting)
	1 Pin 2 of the sensor connector is connected to +24 V
	1 Pin 2 of the sensor connector is connected to ground

[Tab. 5] Controlling pin2 at the sensor connector by placing JP2601 resp. JP2602

1) With the board in the pictured position [46]

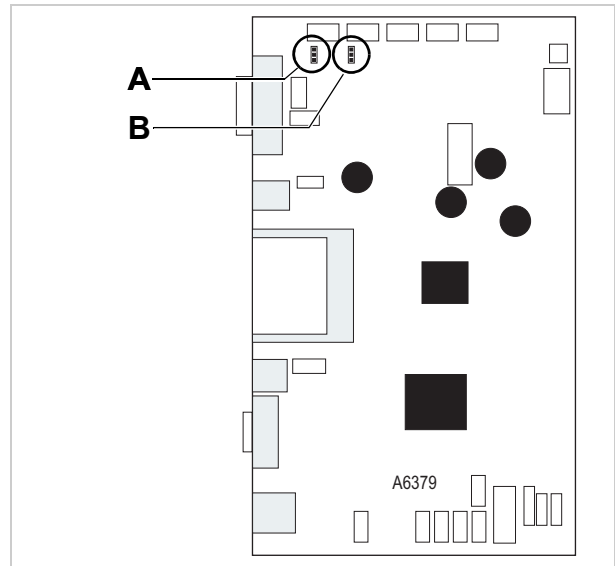

[45] CPU board „Gen. 1“.

- A Position of the jumper JP901 (A) for the control of pin 2 of the *alternative label sensor*
- B Position of the jumper JP902 (B) for the control of pin 2 of the *product photoelectric sensor*

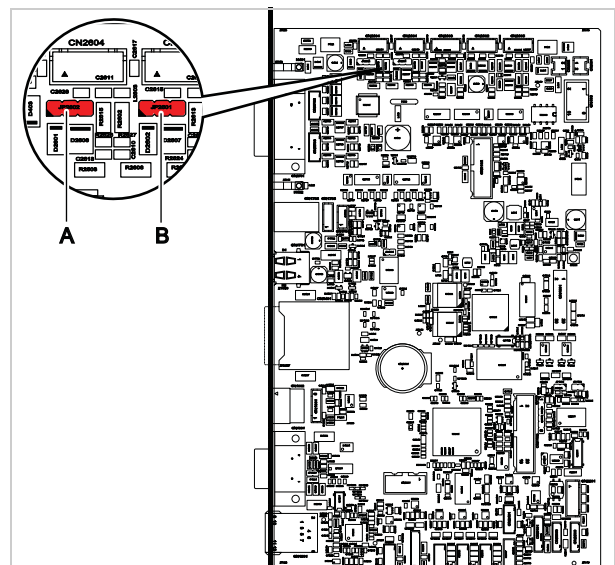

[46] CPU board „Gen. 2“.

- A Position of the jumper JP2602 for the control of pin 2 of the *alternative label sensor*
- B Position of the jumper JP2601 for the control of pin 2 of the *product photoelectric sensor*

Start (product) sensor

The start sensor (= product sensor) starts the dispensing process and is therefore indispensable in most applications. These installation instructions refer to the standard sensor (N102106) [48] offered by Novexx. Alternatively, a sensor with reflector is available (N102109). The bracket of the reflector is mounted in the same way as the sensor.

- Permitted sensor types: PNP or NPN
- Preset: PNP

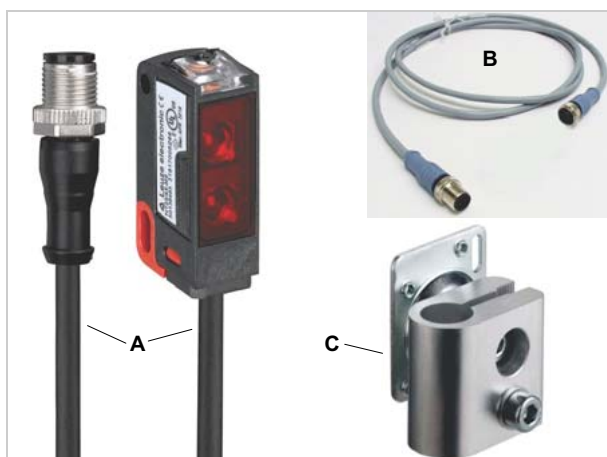

[48] Start sensor complete (N102106). A=Sensor, B=Cable, C=Holder

Assembly

- Push the start sensor with the holder [47A] onto the holding rod [47B] and tighten the clamping screw [47C].

Connecting

- Connect the sensor cable to the cable tail of the sensor [47E] and to the illustrated connection [47D] on the machine.
- Adjust the sensor according to the manufacturer's instructions (comes with the sensor).

For NPN Photoelectric sensor:

- Set the MACHINE SETUP > Startsen. In.Type function to "NPN".

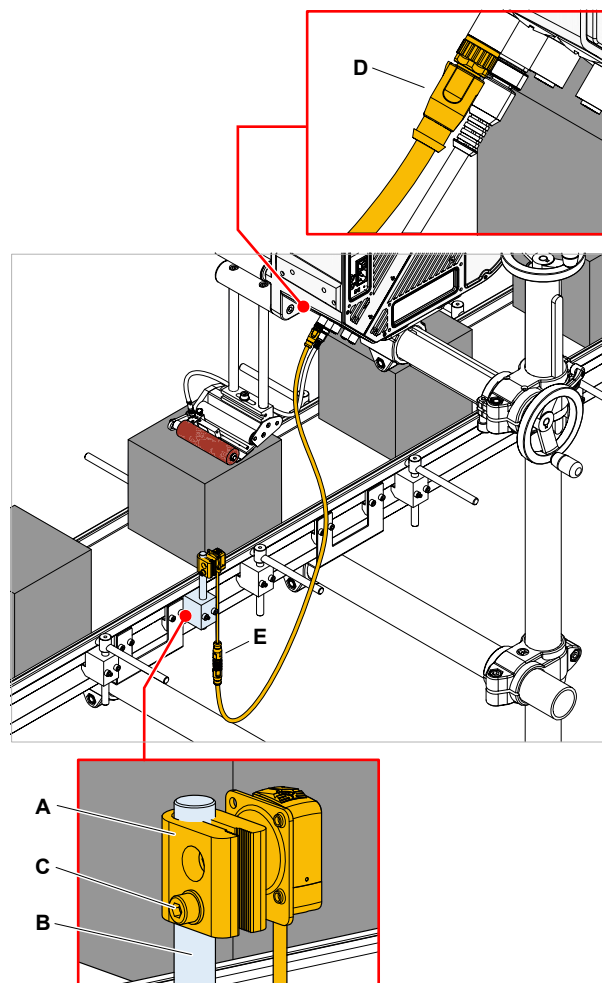

[47] Attaching the start sensor.

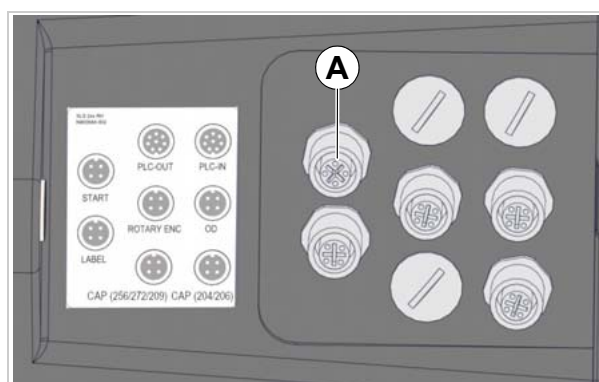

[49] Connection for the start sensor to a RH machine

Pin assignment

Pin	Assignment
1	+24 V
2	+24 V or ground or no connection ¹
3	Ground
4	Sensor signal

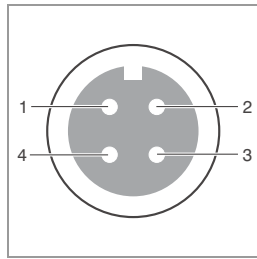

1) Changing light/dark switching at the product sensor or the alternative label sensor on page 37

Connection Diagram

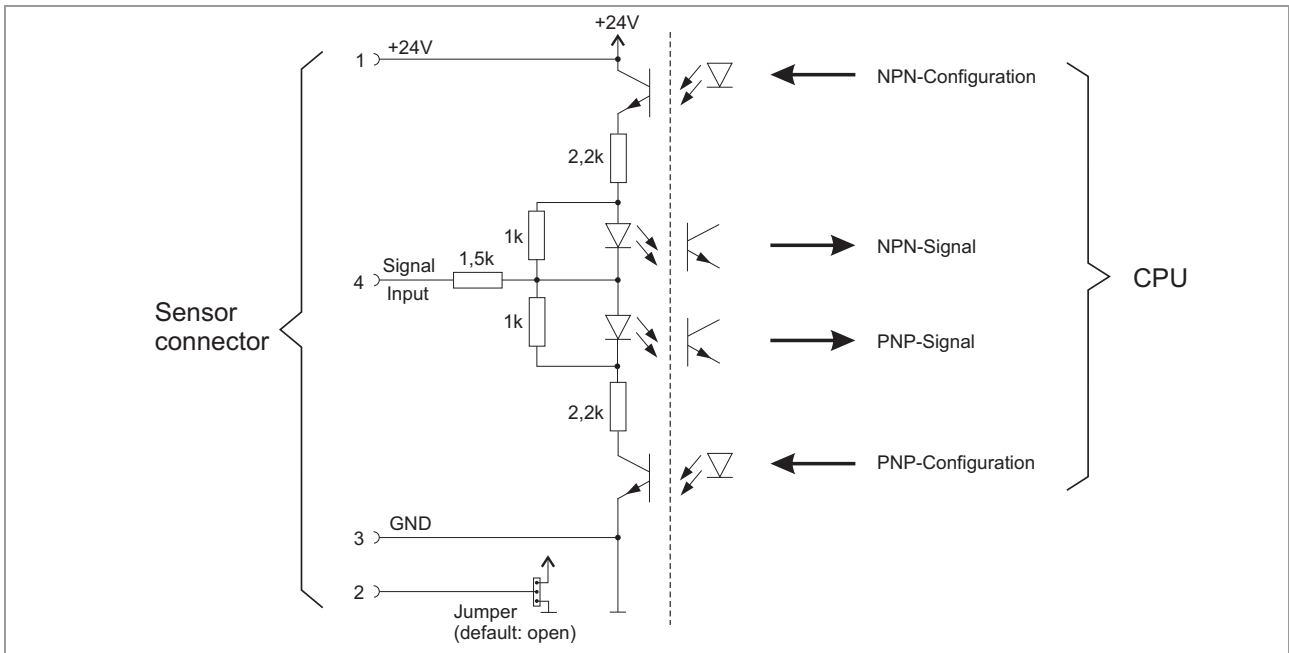

[50] Connection diagram photoelectric product sensor

Photoelectric roll diameter sensor

Both, XLS/ALS 20X as well as XLS/ALS 256 can be used with an optional photoelectric sensor to check the outer diameter (OD sensor) of the label roll. The OD sensor gives a display message when less than a certain residual diameter is left on the label roll.

- Permitted sensor type: PNP
- Order no.: RH A8192, LH A8204

Installing

 Tools:

- Medium size screwdriver
- 2,5 and 8 mm hexagon socket driver

- Remove the following parts from the deviation roller axle: outer lock washer, shim ring(s) deviation roller [51C], shim ring(s) and inner lock washer.
- Remove reflector [52A] and mounting bracket [52D] from the sensor holder.
- Remove the mounting block [52C] (2 screws).
- Move the sensor holder [52B] behind the dancer arm with the upper end first and position it as illustrated [51].
- Push the mounting block onto the deviation roller axle and screw it to the sensor holder.
- Push the shim ring, which came with the sensor unit onto the deviation roller axle.
- Reassemble the deviation roller with shim ring(s) and lock washers, as it was before.
- Fix the upper end of the sensor holder onto the housing, using mounting bracket [52D] and M10 screw.
- Attach the reflector to the sensor holder using two thumb screws.

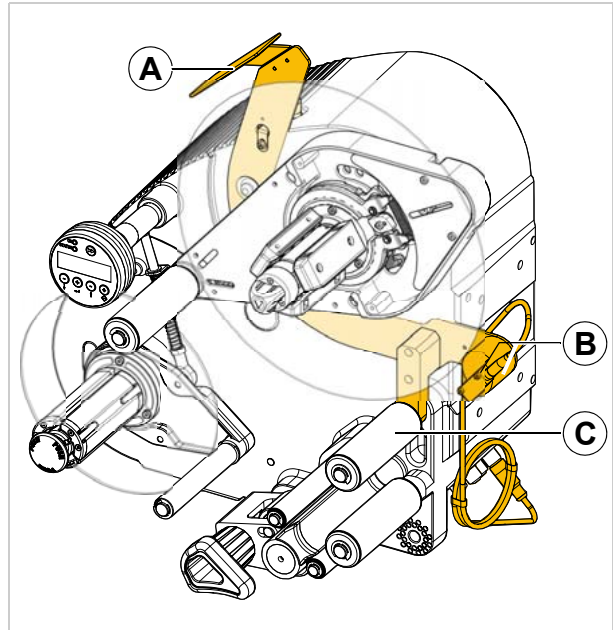

[51] Mounted OD sensor (pictured red).

- A Reflector
- B Sensor

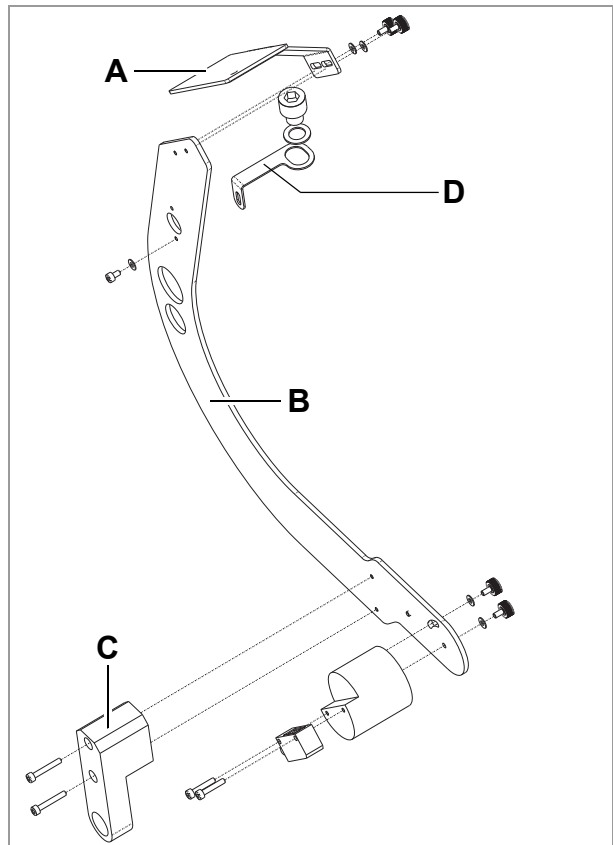

[52] Mounting the OD sensor.

Connecting the OD sensor

→ Plug the roll diameter sensor in to the connector shown [53A].

Alternatively, the OD sensor can be connected to the optional applicator interface (see service manual, chapter **Pin assignment for machine status connection** on page 237).

Pin assignment

Pin	Assignment
1	+24 V
2	not used
3	Ground
4	Sensor signal

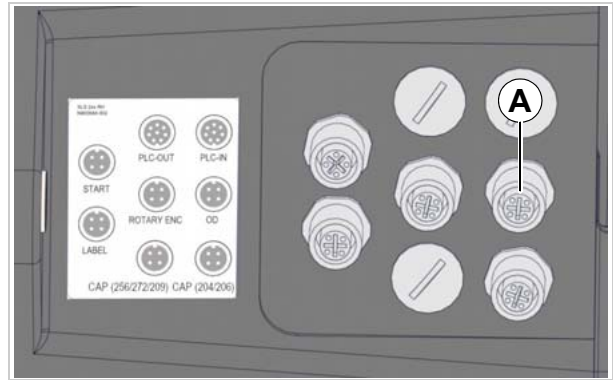
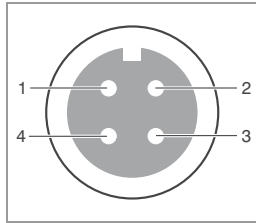

[53] Connection for roll diameter sensor at RH machine

[Tab. 6] Pin assignment for photoelectric OD sensor connection

Connection diagram

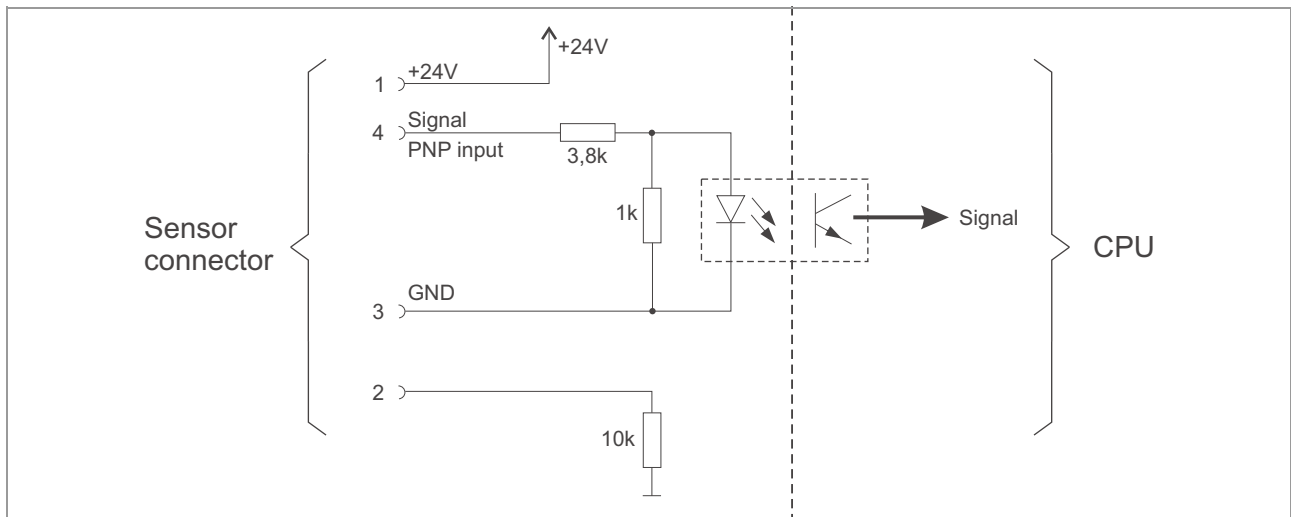

[54] Connection diagram photoelectric RD sensor

Enabling

- Set MACHINE SETUP > OD sensor warn. to „Warning“.
- Set MACHINE SETUP > OD Sens.polarity to „Level low active“.

If the optional applicator interface board is installed, but the standard signal interface is supposed to be used:

- Set SIGNAL INTERFACE >ACTIVE INPUTS > OD sensor signal to „Default input“.

Setting the roll diameter

Prerequisite:

- OD sensor is installed and activated.
- Label material roll with the required remaining diameter is prepared.
- Measure the diameter of the prepared roll.
- Loosen the thumb screws [56A] at the reflector [56B].
- Shift the reflector to the upper [55B] or lower [55A] position (long holes) according to the measured roll diameter (--> tab.). Retighten the thumb screws.

Roll Ø in mm	Roll Ø in Inch	Reflector position
38-122	1,5-4,8	Up
51-135	2,0-5,3	Down

- Insert the prepared label roll.
- Loosen the thumb screws at the sensor [56C].
- Rotate the sensor to the top, until the light beam does not meet the reflector any more.
 - The LED at the sensor is off.
- Slowly rotate the sensor down, until the light beam meets the reflector.
 - The LED at the sensor lights up.
- Rotate the sensor further down, until the light beam is covered by the label roll.
 - The LED at the sensor goes out.
- Tighten the thumb screws.

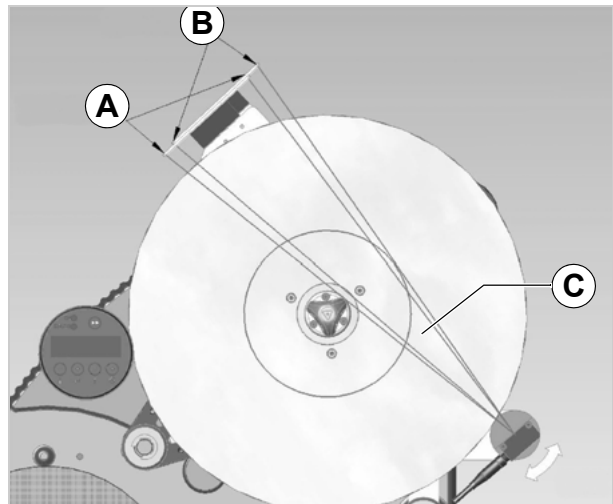

[55] Setting the OD sensor
 A Lower reflector position
 B Upper reflector position
 C Rotating range of the sensor

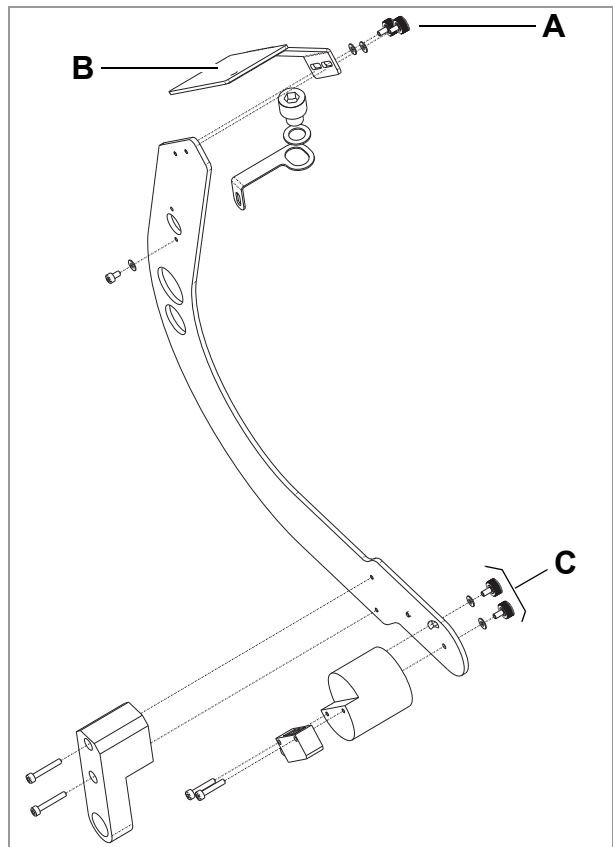

[56] Thumb screws (A, C) which have to be loosened to set the sensor.

Function test

Prerequisite:

- Machine is in dispensing mode.
- OD sensor is activated (settings according to chapter **Enabling**  on page 42).

If the light beam of the sensor [51B] meets the reflector [51A], the following message appears after the next label has been dispensed:

ONLINE
OD sensor warn.

Additionally, the following signals will be activated:

Interface	Signal name	Pin
Standard signal interface	Warning	8
Applicator interface (optional)	OD-Sensor	16

The message disappears immediately, if the light beam stops falling on the reflector.

Note the following, when connecting to the *applicator interface*:

- No status message will be displayed on the operation panel in case of low material (only the „OD sensor“ signal will be activated)
- If no sensor is connected, the output signal „OD sensor“ remains activated

Rotary encoder

For the labeler to be used with automatic speed adjustment, a rotary encoder must be connected. The rotary encoder communicates the conveyor belt speed to the labeler.

Specifications for suitable rotary encoders

Sensor types	Push-Pull or PNP (Recommended: Push-Pull)
Nominal voltage	24 V (DC)
Output current	20 mA for each connected labeler
Resolution	c. 0.4 mm/pulse
Rise time	1 µs
Decay time	1 µs
Frequency	max. 5 kHz (PNP) max. 20 kHz (Push-Pull)
Pulse/pause ratio	1/1 ±12.5%

[Tab. 7] Rotary encoder specifications

About encoder resolution

The minimum resolution is 5 pulses per millimetre of product movement with a maximum of 32767 steps from detection of the start pulse to dispensing of the label = 0.2 mm resolution.

So between 5 and 20 pulses per millimetre of product movement are ideal.

Novexx rotary encoder

Article no.	Article	Image
N103708	Rotary encoder basic kit	
N103707	Mounting kit	

[Tab. 8] Article numbers for Novexx rotary encoder and accessories.

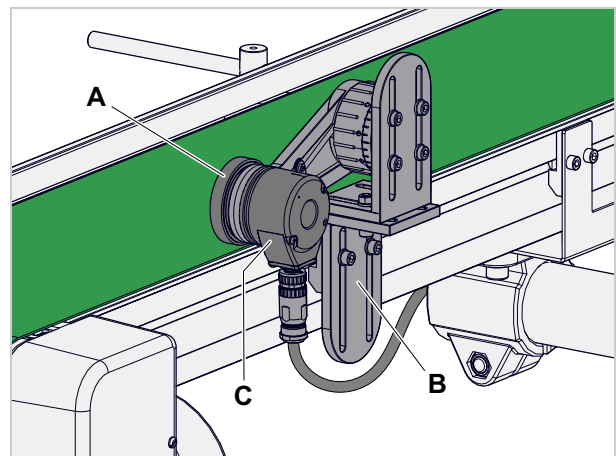

[57] Novexx encoder (C) with measuring wheel (A) and bracket (B) for mounting on a Novexx Solutions conveyor belt.

Article no.	Article	Image
N103709	Rotary encoder kit	
N103696	Rotary encoder	
N103697	Measuring wheel (200 mm circumference, for 10 mm axle)	
N101829	Connection cable (2m)	

[Tab. 8] Article numbers for Novexx rotary encoder and accessories.

Connecting the rotary encoder

CAUTION!
To avoid damage to the electronics:
→ Switch the machine off before connecting the rotary encoder.

→ Plug the rotary encoder in to the connector shown [58A].

i No changeover is necessary for a Push-Pull rotary encoder.

Connecting a M12 connector:

Pin	Common wire colours	Function
1	Brown	+24 V
2	White	Impulse B
3	Blue	Ground
4	Black	Impulse A

For details on how to set up an encoder and operate with automatic speed adjustment (APSF), see chapter **Automatic dispensing speed adjustment** on page 108.

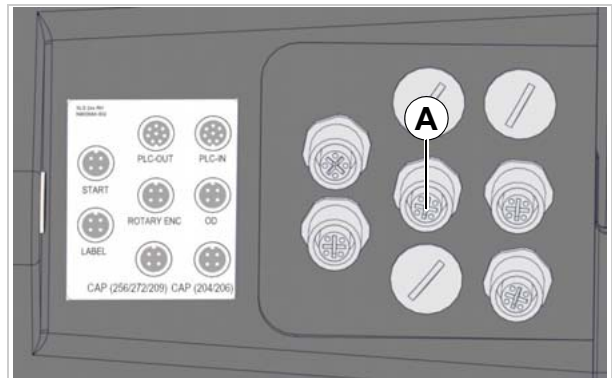

[58] Rotary encoder connection at RH machine.

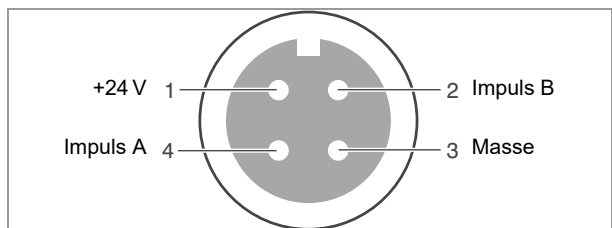

[59] Pinbelegung am Anschluss für den Drehgeber



[60] M12-Stecker (Artikelnummer: A8142 für Kabel-Ø 4-6 mm, A8143 für Kabel-Ø 6-8 mm)

Connection diagram

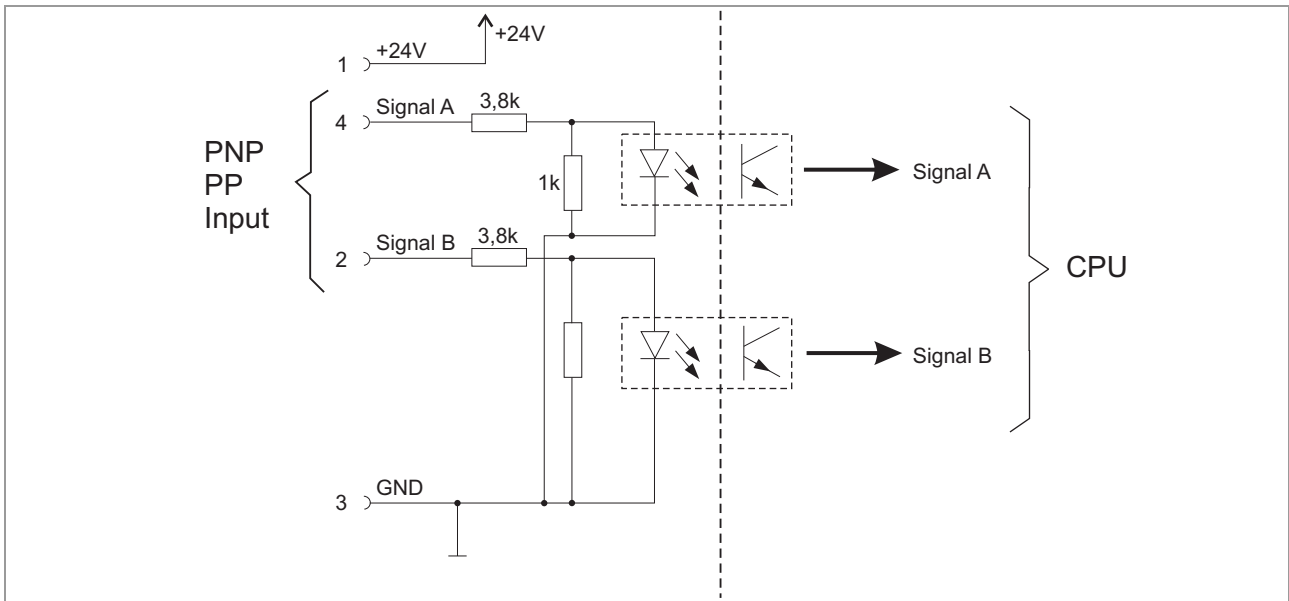

[61] Connection diagram rotary encoder

INSTALLING OPTIONS

Connecting / mounting the external operator panel

Operating notes

XLS 2xx: There is no special external operator panel for use with the XLS 2xx. The external operator panel for ALS 2xx can be used.

External and built-in operator panel can be used alternately.

Connecting to a standard machine

The external operator panel is necessary, if the labeller is installed at an inaccessible place.

The cable installed to the operator panel is 2.5 m long.

CAUTION!

If the connection cable is longer than 2.5 m, EMC-caused disturbances can occur.

- Only use the factory-installed cable.
- Don't extend the cable.

→ Connect the external operator panel to the mini-DIN connection [63A].



[62] External operator panel (Article number: A7474)

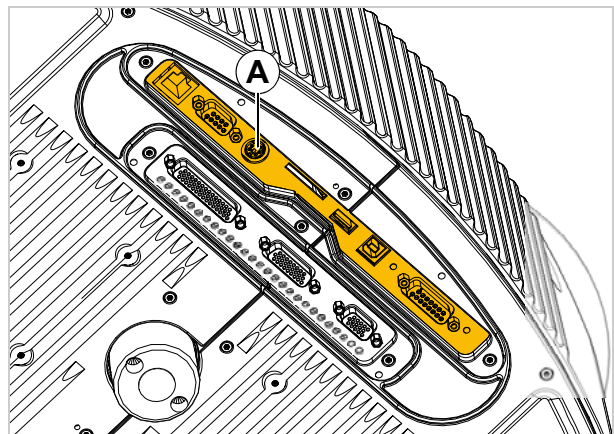

[63] Connection (A) for external operator panel.

Connecting to a machine with splash guard

The operator panel cable is led into the cover box by means of a split cable gland.

Prerequisite:

- ALS/XLS 20x with splash guard
- *Split cable gland* (comes with the machine resp. is contained in the cable gland kit A107182)



Together with the split cable gland come two cable inserts for two different diameter ranges (3-4 mm, 5-6 mm). Use the insert with the wider opening. The inserts are split at one side.



Tool:

- Open-ended spanner SW 26

Procedure:

- Remove the cover plate [4A] from the cover box.
- Turn out the cap [4B] from the cover box.
- Slightly spread the cable insert [4D] to insert the cable.
- Position the cable insert on the cable in a way that there is sufficient free cable left inside of the cover box for both: connecting the cable and mounting the cover box.
- Insert the cable insert into the two housing halves [4E].
- The slot in the insert must be placed on the same side as the slot between the two housing halves.
- Feed the operator panel cable [4C] through sealing [4F], cover plate and nut [4G].
- Push the seal ring [4F] over the thread.
- Insert the cable gland into the opening in the cover box and fix it with the nut [4G] from inside.
- Connect the cable (see chapter above).
- Reassemble the cover plate.

Mounting the external operator panel



Tool:

- Cross-head screwdriver, medium size

- Drill 2 holes according to the drawing beside [65, Arrows].
- Open the operation panel housing (4 screws).
- Mount the lower part of the housing using 2 M4 screws.
- Close the operator panel housing.

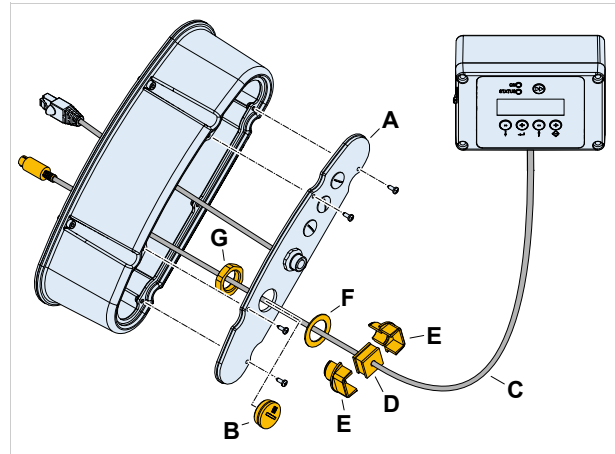

[64] Feeding the operator panel cable through the cover box.

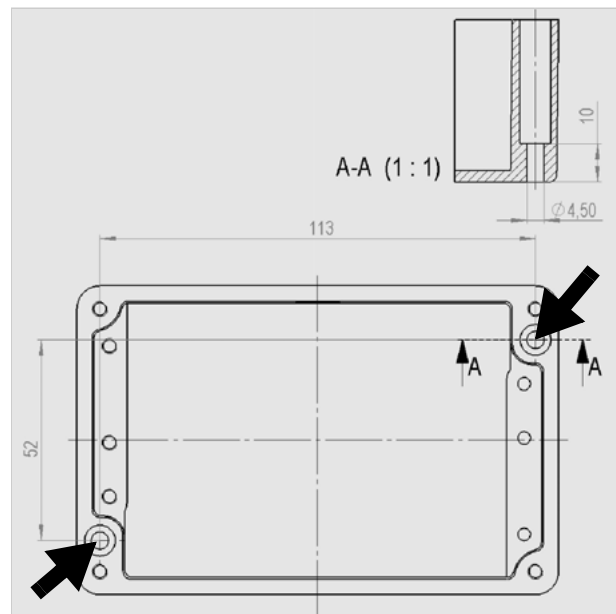

[65] Hole distances for wall mounting of the external operator panel.

Mounting a splice table

With the splice table option, the end of the preceding material roll can be taped to the beginning of the new roll. Thus, the material doesn't have to be fed through the whole machine for each new material roll, what reduces the downtimes for material change.

 Tool:
– 8 mm allen key

Article numbers:

- A107825 Splice table
- 000165-21 Screw M10x16 (4 pieces required)
- 000091-22 Washer 10.5 (4 pieces required)

Mounting (RH machine):

→ Screw the splice table [67A] to the flange on top of the machine using the 4 screws [67B] and washers.

 Tightening torque: 45 Nm

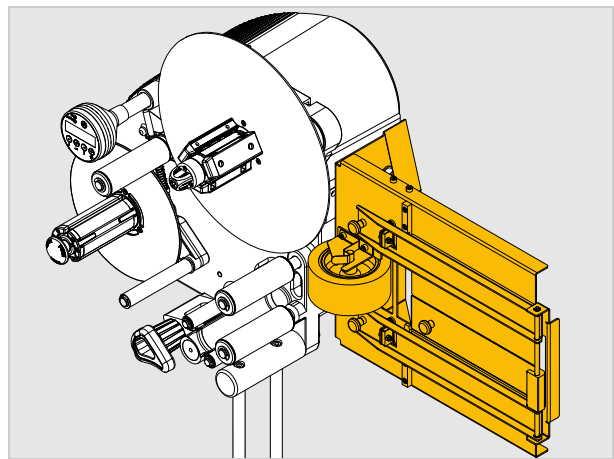

[66] Splice table on an ALS 20x.

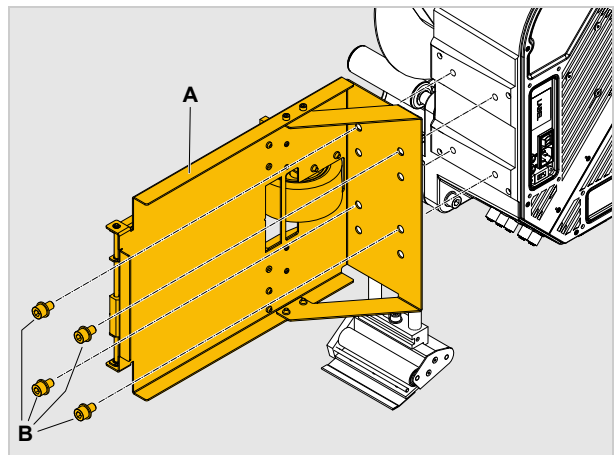

[67] Mounting the splice table (A).

Mounting/connecting the signal beacon

NOVEXX Solutions offers a ready to use signal beacon for the ALS/XLS 20x and ALS/XLS 256. The LED lamps of the beacon show the colors red-yellow-green. The beacon can be connected to different signal interfaces, using the optional available cables.

Article numbers:

- *Signal beacon* (with mounting angle, without cable): N100493
- *Connection cables*:

Article number	Connection to interface
N100491	Standard ¹ (D-sub 15) [69A]
N100496	PLC out ¹ (M12) [69C]
N100492	AI ² (HD-sub 26) [69B]

- 1) Required setting: SIGNAL INTERFACE > Interface mode = „PLC signals“
- 2) Option

The beacon can signal the following machine states:

- Error (red)
- Warning (yellow)
- Ready (Green)

Attach the signal beacon at the machine:

Tools:

- Hex socket screwdrivers 4 and 8 mm
- Spanner SW 17

- Screw the threaded bolt [68A] into one of the threaded holes on the machine and lock it with the nut [68C]
- The tapped hole on the top of the housing [68B] or one of the holes on the mounting flanges can be used for mounting.
- For side mounting, swivel the threaded bolt by 90°. To do this, loosen the clamping screw [68D].

Connecting:

- Unscrew the lamps [69E] from the holding tube [69D].
- Push the cable with the M12 connector [69F] through the holding tube and connect the connector to the bottom of the lamps.
- Screw the lamps back onto the holding tube.
- Connect the cable to the machine [69A, B or C, see table].

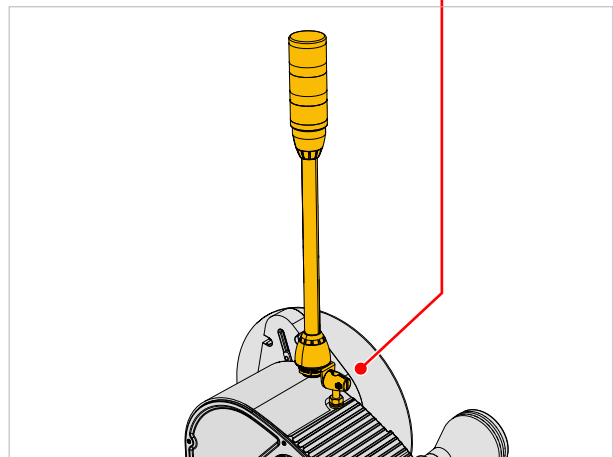
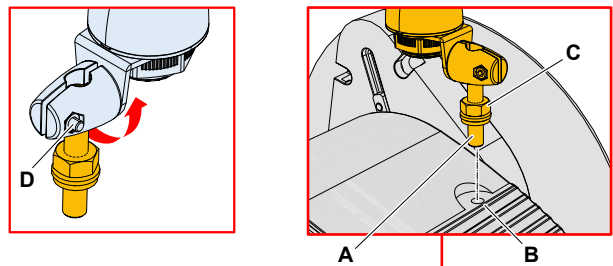

[68] Mounting the signal beacon.

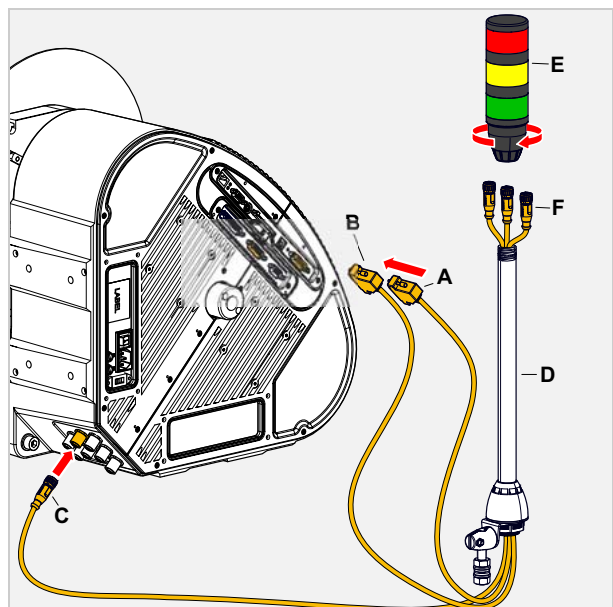

[69] Various connection options for the signal beacon.

Adjustable dispensing edge holder

- Tool:
- 8 mm hexagon socket driver

The standard dispensing edge holder can be replaced by the optional adjustable dispensing edge holder [70], which enables a height adjustment of the dispensing edge.

- Adjustment range: 70 mm in steps of 0.2 mm [72]
- Mounting is possible in different angles in steps of 15°, as with the standard dispensing edge holder
- Article no.: RH A8018, LH A8138

Adjusting:

- Rotate the adjustment wheel [70A], until the intended height is reached.

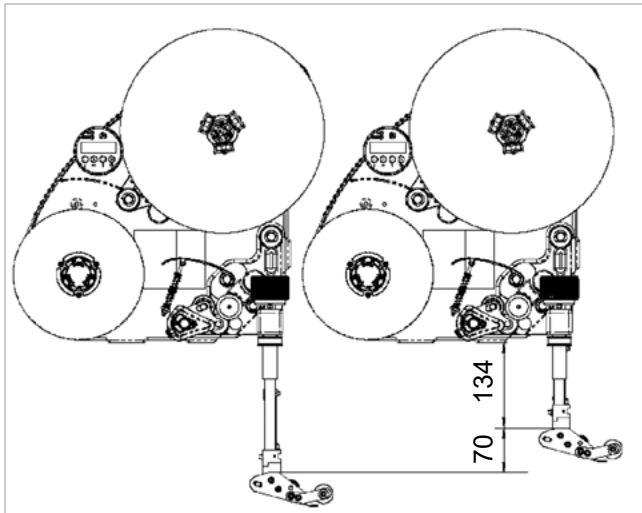

[72] Adjustment range of the adjustable dispensing edge holder.

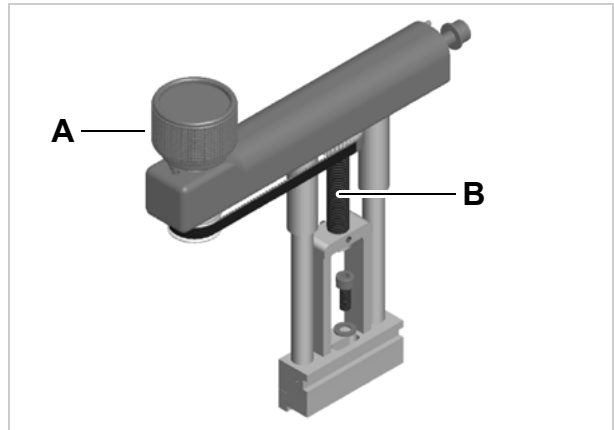

[70] Adjustable dispensing edge holder.
A Adjustment wheel
B Spindle

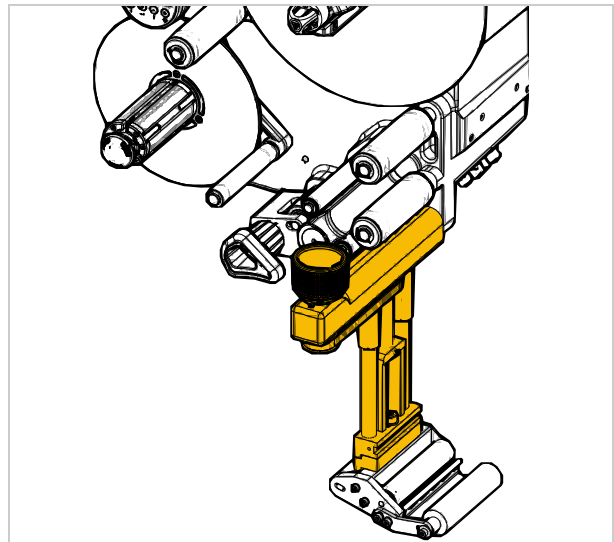

[71] Adjustable dispensing edge holder in place.

Rotatable dispensing edge holder

The rotatable dispensing edge holder is recommended for applications that require the dispensing edge holder to be swivelled to the front. Depending on the swivelling angle, the holder has to be set up differently (see the following chapters).

Machine	Article number
ALS/XLS 204 LH	A107659
ALS/XLS 204 RH	A107658
ALS/XLS 206/256 LH	A107631
ALS/XLS 206/256 RH	A107636
ALS/XLS 209 LH	N100203
ALS/XLS 209 RH	N100202

[Tab. 9] Article numbers of the rotatable dispensing edge holder.

Rotation angle up to 15°

 Tools:
– 2.5/3/8 mm Allen keys

Setting up the dispensing edge holder:

→ Disassemble the bearing plate [73A], roller [73B] and bearing angle [73C].

Assembly:

- Locate the pins [74C] in diametrically opposite holes.
- Choose either inner or outer circle of holes, dependent on angle required.
- Fit the dispensing edge holder [74D] onto the pins [74C] at the required angle.
- Fix the dispensing edge holder in place with screw [74A].

 Tightening torque: 45 Nm

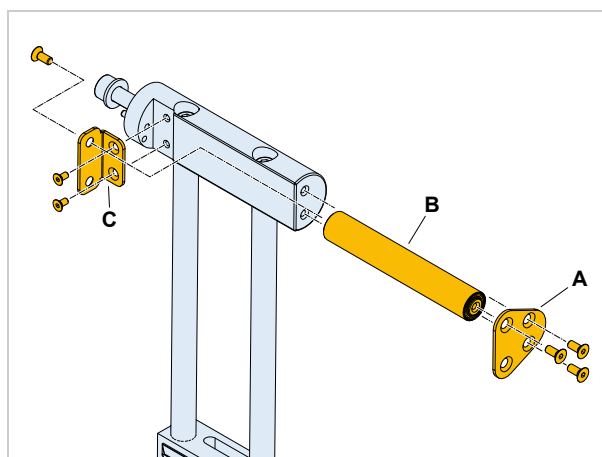

[73] Disassembling bearing plate (A), roller (B) and bearing angle (C).

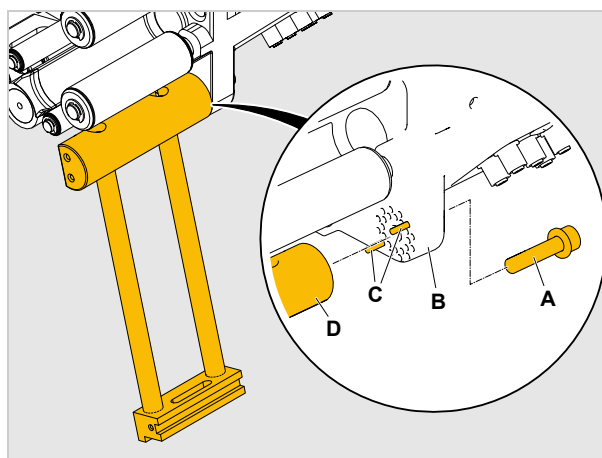

[74] Assembling the dispensing edge holder at an angle of 15°.

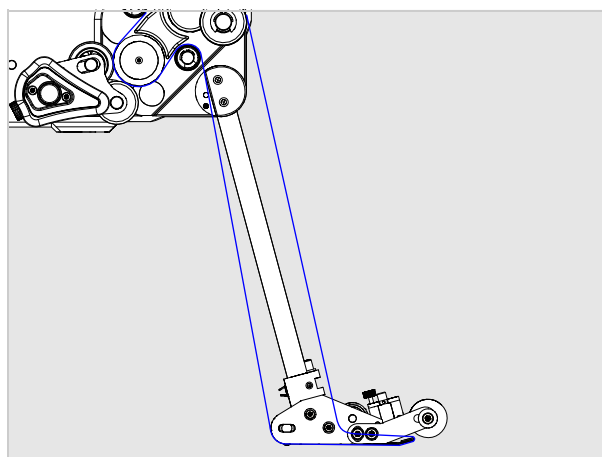

[75] Material web path at the 15° rotated dispensing edge holder.

Rotation angle from 15° to 30°

- Tools:
- 2.5/3/8 mm Allen keys

Setting up the dispensing edge holder:

→ Install the roller [76A] in the *lower* position [76B].

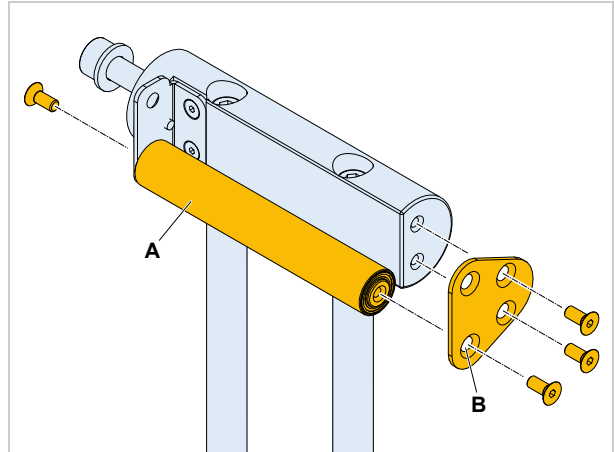

[76] Install the roller (A) in the lower position (B).

Assembly:

- Locate the pins [77C] in diametrically opposite holes.
- Choose either inner or outer circle of holes, dependent on angle required.
- Fit the dispensing edge holder [77D] onto the pins at the required angle.
- Fix the dispensing edge holder in place with screw [77A].

- Tightening torque: 45 Nm

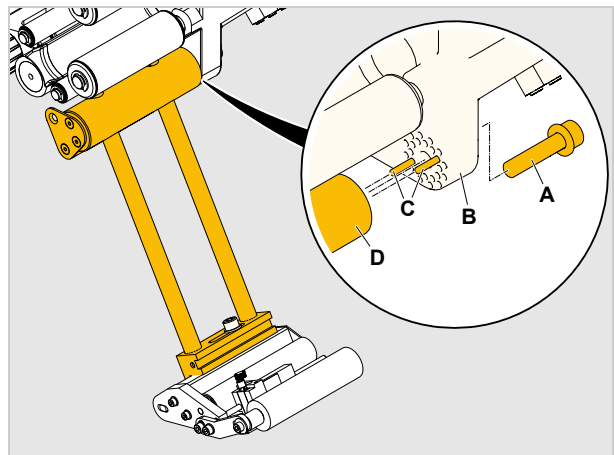

[77] Assembling the dispensing edge holder at an angle of 30°.

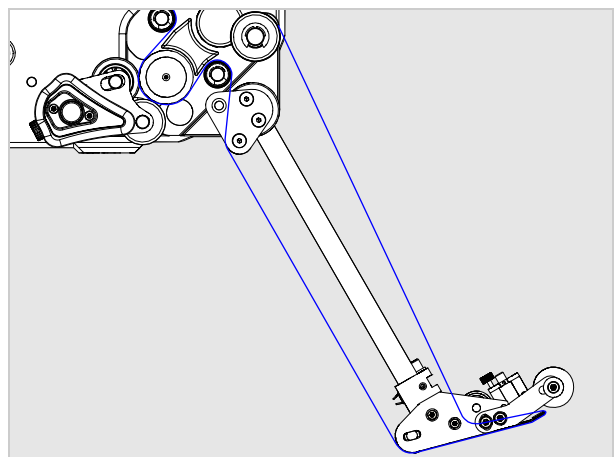

[78] Material web path at the 30° rotated dispensing edge holder.

Rotation angle from 30° to 90°

- Tools:
- 2.5/3/8 mm Allen key

Setting up the dispensing edge holder:

→ Install the roller [79A] in the *upper* position.

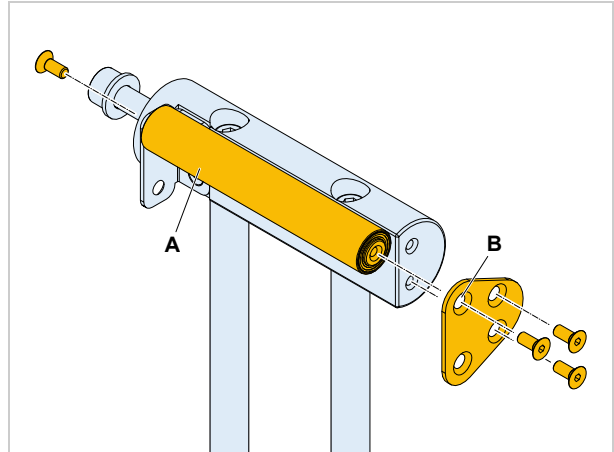

[79] Install the roller (A) in the upper position (B).

Assembly:

- Locate the pins [80C] in diametrically opposite holes.
- Choose either inner or outer circle of holes, dependent on angle required.
- Fit the dispensing edge holder [80D] onto the pins at the required angle.
- Fix the dispensing edge holder in place with screw [80A].

- Tightening torque: 45 Nm

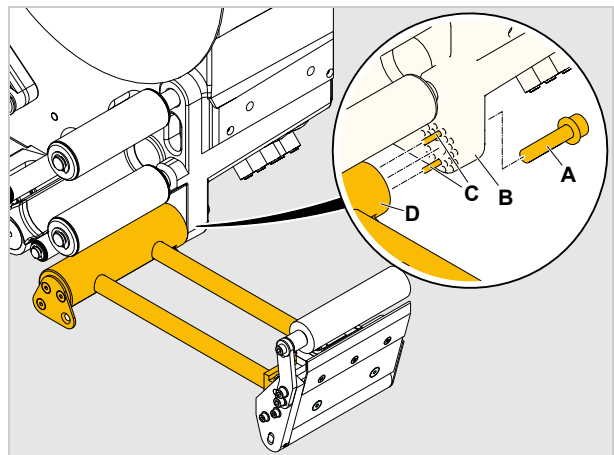

[80] Assembling the dispensing edge holder at an angle of 90°.

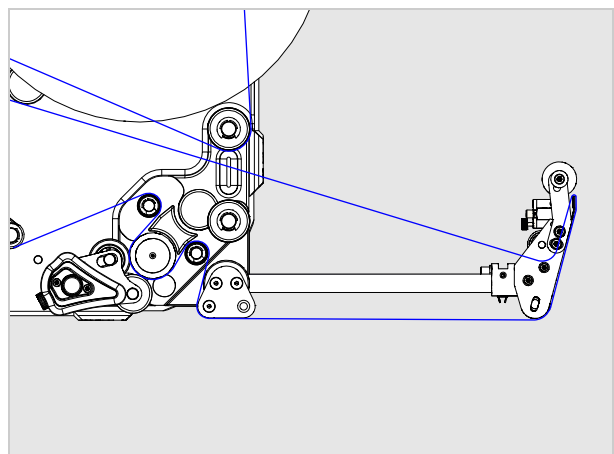

[81] Material web path at the 90° rotated dispensing edge holder.

DECOMMISSIONING, DISMANTLING, DISPOSAL

Take the machine out of operation

Disconnecting the machine from the compressed air supply (only machines with installed applicator):

- Switch off the compressed air supply of the applicator.
- Disconnect the compressed air hose from the applicator.
- For details read the applicator installation manual.

Disconnect the machine from the power supply:

- Switch the machine off at the mains switch (switch position „0“ or „switch illumination off“ for machines with splash guard).
- Pull out the mains plug from the mains socket or disconnect the power cord from the electrical cabinet.
- Disconnect all cables at the machine.

Dismantling the machine

Machine with installed applicator:

- Remove the applicator.
- For details read the applicator installation manual.



WARNING!

Danger of injury by the machine falling to ground.

- Let the machine be hold by at least 2 persons, while a 3rd person loosens the clamping at the support stand.
- Wear safety footwear.

Acute risk of injury and long-term bodily injury from working with heavy loads!

- Lift or carry the machine with a minimum of 2 persons. If possible, use a crane or other lifting device.

CAUTION!

To avoid damaging the machine during transport:

- Never hold the machine by the deflection rollers, dancer arm or rewind or unwind unit.

- Let the machine be held by at least 2 persons, while a 3rd person loosens the clamping at the support stand.
- While doing so, hold the machine at its housing.
- Strip the machine from the support stand tube and lay it down.

Machine disposal



It is advisable to remove reusable machine components as long as the machine is firmly mounted.

- Remove machine parts which can be reused (e. g. applicator, applicator interface, dispensing edge holder, dispensing edge).
- Dispose of the remaining machine parts separated by material groups in an environmentally acceptable manner. Observe the national regulations.
- Dispose of waste properly, i.e. sorted according to the material groups of the parts to be disposed of. The aim should always be to achieve a maximum possible reutilisation of the basic materials combined with the minimum possible environmental impact.

Functions

FUNCTION MENU

Overview

LABEL SETUP	MACHINE SETUP	(continued)	INTERFACE PARA	(continued)
Load prod.profil	Dispenser type	Label sens. type	>EASYPLUGINTERPR	DHCP host name
Gap detect. mode	Store prod.prof.	Labelsens. InType	Interface	FTP server
Dispense speed	Del. prod.profil	Startsen. In.Type ⁹	Dispenser ID no.	FTP Password
Slew speed	Dispense counter	Start disp. mode	Spooler size	WEB server
Label pitch	Disp. Cnt. Reset	Start error stop		WEB admin passw.
Lab. stop offset	Factory settings	On inhibit enter	>COM1 PORT	WEB supervisor p.
Start offset	Custom defaults	On inhibit leave	Baud rate	WEB operator p.
Product length	Store Parameters	Turn-on mode	No. of data bits	
Multi label mode	Auto Sensor Adj. ³	Language	Parity	
Label 2 offset ^{1a}	Sensor Adjust ³	Access authoriz.	Stop bits	
Label 3 offset ^{1b}	Speed Adaption	Materialend err	Data synch.	
Miss. label tol.	Encoder Type ⁴	Materialend warn	Frame error	
Miss. label mode	Encoder Resol. ⁴	Rewinder full		
Stop count. mode	Encoder Diameter ⁴	Ext. OD sensor	>NETWORK PARAM.	
Label stop quan. ²	Rewinder Operat.	OD Sens.polarity ⁷	IP Addressassign	
	Tandem Operation		IP address	
	Tandem startmode ^{5,10}		Net mask	
	Tandem synchron. ⁵		Gateway address	
	Slave IP address ⁶		Port address	
	Ready Mode Slave ⁵		Ethernet speed	
	Tandem Distance ⁵		MAC Address	

[Tab. 10] Overview of functions in the functions menu – part 1 (grey shading = only appears in production mode).

- 1a) Only appears if LABEL SETUP > Multi label mode = „x labels/start“.
- 1b) Only appears if LABEL SETUP > Multi label mode = „3 labels/start“.
- 2) Only appears if LABEL SETUP > Stop count. mode = „On“.
- 3) Only appears if MACHINE SETUP > Label sens. type = „Wenglor“.
- 4) Only appears if MACHINE SETUP > Speed Adaption = „On“.
- 5) Only appears if MACHINE SETUP > Tandem Operation = „Master“, „Flipflop master“ or „Slave“.
- 6) Only appears if „Tandem Operation“ = „Master“ or „Master flipflop“ and if „Tandem synchron.“ = „UDP Tandem Port“.
- 7) Only appears if MACHINE SETUP > Ext. OD sensor = „Error“ or „Warning“.
- 8) Only appears if INTERFACE PARA > NETWORK PARAM. > Time client = „On“.
- 9) Only appears if MACHINE SETUP > Label sens. type = „Capacitiv“.
- 10) Only appears with „Gen. 2“ electronics and firmware 2.50 or higher.

SIGNAL INTERFACE	(continued)	SERVICE/DIAGNOS.	SERVICE DATA	(continued)
Interface mode	>AI BOARD SIGNAL ¹⁴	Service	>MODULE FW VERS.	Work place
>PLC SIGNALS ⁹	Applicator type	Serv. data reset	System version	Company name
End dispense mod	Apply mode	Sensor Test	System revision	
Disp. end delay	Start mode	PS registers ¹⁹	System date	>DISPLAY DATA
End pulse width	Dwell time ¹¹	Memory card test	Applicator int. ¹⁶	Display Version
	Blow on time ¹²	Test functions		Display serialNr
>APPLIC. SIGNALS ¹⁰	Restart delay	Store diagnosis	>OPERATION DATA	Remote disp.vers ¹⁷
Applicator type	Position timeout ¹³	Gen.Support Data	Service operations	Remote disp. ## ¹⁷
Status outputs	Apply comp. time	Data blocks del.	Tot. mat. length	
Apply mode	Touch down sens. ²⁰		Dispensing cycl.	>MEMORY DATA
Dwell time ¹¹	TouchDownTimeout ²⁰		Operation time	RAM memory size
Blow on time ¹²			Total Operation	Flash mem size
Restart delay	>AI BOARD SIGNAL ¹⁵			Custom defaults
Position timeout ¹³	Status signals		>POWERSUPPLYDATA	
Apply comp. time			Type	
Touch down sens. ²⁰	>ACTIVE INPUTS		Version	
TouchDownTimeout ²⁰	Start signal		Serial number	
	Inhibit signal		PS Temperature	
	OD sensor signal		Standby+On time	
			>CPU BOARD DATA	
			CPU identifier	
			PCB Revision	
			FPGA version	
			MAC Address	
			Serial number	
			Production date	
			PCB part number	
			Board part numb.	
			Manufacturer	

[Tab. 11] Overview of functions in the functions menu – part 2 (grey shading = only appears in production mode).

- 9) Only appears, if Interface mode = „PLC signals“
- 10) Only appears, if Interface mode = „Applic. signals“
- 11) Only appears if Applicator type = PEP, „PEP Blow on“, „Reverse PEP“, BTS or „LA-TO Timed“
- 12) Does not appear if Applicator type = „LTP - LTPV“, PEP, „Direct Dispense“, „LA-TO Sensor“ or „LA-TO Timed“
- 13) Does not appear if Applicator type = ASA, „Direct Dispense“ or LA-BO
- 14) Only appears with AI board installed *and* if Interface mode = „Applic. signals“
- 15) Only appears with AI board installed *and* if Interface mode = „PLC signals“
- 16) Only appears with AI board installed
- 17) Only appears if remote display is connected
- 19) Only with ALS/XLS 256 and ALS/XLS 272
- 20) Only appears if Applicator type = „LTP - LTPV“, „PEP II Sensor“, „LA-TO BO Sensor“, „O-ring applicat.“ or „LA-TO Sensor“

Notes on the description of functions



The adjustment range or individual settings available for a function are shown in square brackets.

- For functions with individual values for settings, the default value is printed in italics.
- Quotation marks are set around values for settings that consist of more than one word.

LABEL SETUP menu

Load prod.profil function

- For loading product profiles from the internal database.
- Product profiles contain product-specific settings.
- A maximum of 16 product profiles can be selected.
- The number of a product profile can only be selected when there is already a profile saved under this number.

Gap detect. mode function

- After one of the following events, the printer must always search for the punch, that is initialize the label material: after switching the device on; after changing the label material.
- Settings: [Manual, „Autom. forward“]
Manual: The operator has to initialize the material always manually by pressing the feed button several times.
Autom. forward: The material initialization is always done automatically, if necessary.

Dispense speed function

- Speed at which the label is dispensed
- Adjustment range:
ALS/XLS 204: [1.0...40.0] m/min; default: 10.0
ALS/XLS 206: [1.0...30.0] m/min; default: 10.0
ALS/XLS 209: [1.0...25.0] m/min; default: 10.0
ALS/XLS 256: [1.0...50.0] m/min; default: 10.0
ALS/XLS 272: [1.0...70.0] m/min; default: 10.0

Slew speed function

- Feed speed which is driven over missing-label-gaps and during measuring of the label length.
- Adjustment range:
ALS/XLS 204: [1.0...40.0] m/min; default: 1.0
ALS/XLS 206: [1.0...30.0] m/min; default: 1.0
ALS/XLS 209: [1.0...25.0] m/min; default: 1.0
ALS/XLS 256: [1.0...50.0] m/min; default: 1.0
ALS/XLS 272: [1.0...70.0] m/min; default: 1.0

Label pitch function

- Label pitch = label length + gap
- Adjustment range: [5.0...600.0] mm; default: 100.0 mm

Lab. stop offset function

- Defines the stopping position of the label at the dispensing edge
- The setting equals the distance between label sensor and dispensing edge
- Adjustment range: [0.0...999.9] mm; default: 20.0
- At application at high dispensing speed in combination with short labels, the value should be > 20 mm



See user manual, chapter „Operation“ > „Configuration and monitoring“ > „Function menu settings“ > „Label stop position“

Start offset function

The function has a different effect on slave machines in tandem operation.

Standard operation or master machine:

- Distance between photoelectric product sensor and apex of dispensing plate. The setting influences the label position on the product.
- Adjustment range: [15.0...2999.9] mm; default: 15.0

Slave machine:

- Fine adjustment of the label position on the product.
- Adjustment range: [-30.0...+30.0] mm; default: 0.0

Product length function

- Start signals coming in during the set product length are suppressed.
- Adjustment range: [0.0...1999.9] mm; default: 0.0 mm



The Product length function is e. g. helpful for products with uneven surface, which would trigger several start signals.

Multi label mode function

- Settings: [Off, „x labels/start“]
- Off: Each start signal causes dispensing of one label.
- „x labels/start“: Each start signal causes dispensing of x labels; x = [2...20]
- x > 3: The distance of all following labels after the 2nd label matches the value set in LABEL SETUP > Label 2 offset.



The „Multi label mode“ function works only if a standard signal input (M12 or D-Sub 15) is used - it *doesn't work*, if an Applicator Interface is applied as signal input.

Label 2 offset function

- Only appears if LABEL SETUP > Multi label mode = „x labels/start“.
- Defines the distance of the 2nd label and of all following labels, if x > 3 (see LABEL SETUP > Multi label mode function). The distance is measured from the front label edge of the preceding label.
- Setting range: [x...9999.9] mm; Default: x, with x = LABEL SETUP > Label pitch.

Label 3 offset function

- Only appears if LABEL SETUP > Multi label mode = „3 labels/start“.
- Defines the distance of the 3rd label for the LABEL SETUP > Multi label mode function (see above). The distance is measured from the front label edge of the preceding label.

- Setting range: [x...9999.9] mm; Default: x, with x = LABEL SETUP > Label pitch.

Miss. label tol. function

- Tolerance for missing labels
- Maximum permitted number of labels missing consecutively from the label ribbon
- Adjustment range: [0...10]; default: 1

Miss. label mode function

- Determines the treatment of missing labels
- Settings: [*Compensate*, *Simulate*]

Compensate: Quick feeding with slow speed (see LABEL SETUP > Slow speed) until the next label arrives at the label sensor. A missing label will be passed with slow speed and the next label will be applied onto the product with a corresponding offset. The offset depends on the speed settings.

Simulate: Feeding in dispensing speed. Missing labels are simulated. A missing label will be simulated by a „virtual label“, there will be no physical label applied onto the product.

Application example: Operation of a printer, which is mounted to the holding rods of the L-shaped dispensing edge some label length above the dispensing edge. In „Compensate“ mode, one or more labels would pass the printer unprinted.

With both settings, the machine switches into error state, if the max. admissible number of missing labels (LABEL SETUP > Miss. label tol.) is exceeded (machine stops; error message; error signal active).

Stop count. mode function

- Settings: [*On*, *Off*]

On: The dispense counter counts down from the value set in LABEL SETUP > Label stop quan. When the counter reaches 0, no further labels are dispensed.

Off: The labeler counts up, i.e. each label dispensed increases the counter reading.

Label stop quan. function

- After this amount of dispensed labels, the dispenser stops
- Function only appears, if LABEL SETUP > Stop count. mode = „On“
- Setting range: [0...99999]; default: 0

MACHINE SETUP menu

Dispenser type function

- Sets the firmware to fit the machine type. The setting must match the machine type!
- (ALS 2xx, ALS 30x) Settings: [„ALS 204 RH“, „ALS 204 LH“, „ALS 206 RH“, „ALS 206 LH“, „ALS 209 RH“, „ALS 209 LH“, „ALS 272 RH“, „ALS 272 LH“, „ALS 309 RH“, „ALS 309 LH“, „ALS 306 RH“, „ALS 306 LH“, „ALS 256 RH“, „ALS 256 LH“, „ALX 734 RH“, „ALX 734 LH“, „ALX 735 RH“, „ALX 735 LH“, „ALX 736 RH“, „ALX 736 LH“].
- (XLS 2xx) Settings: [„XLS 204 RH“, „XLS 204 LH“, „XLS 206 RH“, „XLS 206 LH“, „XLS 209 RH“, „XLS 209 LH“, „XLS 272 RH“, „XLS 272 LH“, „XLS 256 RH“, „XLS 256 LH“].

Store prod.prof. function

- Saves the current settings as a product profile



The extent of the stored functions is the same as described in MACHINE SETUP > Store Parameters = „Without adj. par“ (file „setup.for“), except for the following functions: MACHINE

Auto Sensor Adj. function

- Automatically adjusts photoelectric label sensor
- Starts slowly feeding label material until the next gap between labels
- The setting that was automatically detected is shown briefly after successful adjustment. The setting can be checked or altered using the function: MACHINE SETUP > Sensor Adjust

Sensor Adjust function

- Adjusts the photoelectric sensors
- Adjustment range: [0...100] %; default: 41

Speed Adaption function

- Speed adjustment
- Settings: [On, Off]

On: The dispensing speed adapts automatically to match the speed of the conveyor belt. A rotary encoder must be installed in order to use this function. In addition, the functions MACHINE SETUP > Encoder Type, MACHINE SETUP > Encoder Resol. and MACHINE SETUP > Encoder Diameter must be adjusted (see below).

Off: The dispensing speed remains constant, at the value that was set using the function LABEL SETUP > Dispense speed.

Encoder Type function

- Type of rotary encoder used
- Settings: ["Single Phase", „2 Phases normal“, „2 Phases invert.“]
- Appears only if MACHINE SETUP > Speed Adaption = „On“.
- See chapter [Entering the rotary encoder type](#)  on page 110

Encoder Resol. function

- Resolution of the rotary encoder used
- Adjustment range: [0.0...9999] pulses/turn; default: 500
- Appears only if MACHINE SETUP > Speed Adaption = „On“.
- See chapter [Entering the rotary encoder resolution](#)  on page 110

Encoder Diameter function

- Diameter of the measuring wheel of the rotary encoder used
- Adjustment range: [0.0...200.0] mm; default: 64.0
- Appears only if MACHINE SETUP > Speed Adaption = „On“.
- See chapter [Entering the diameter of the measuring wheel](#)  on page 110
- Display:

Encoder Diameter	
200.0 mm	20.6 var

The diameter of the measuring wheel is shown on the left. The current product speed as calculated by the machine appears on the right. If this speed is not equal to the actual speed, the setting for the measuring wheel diameter can be changed to align the actual and measured values for the conveyor speed.

Example shown on display: The speed of the conveyor belt is calculated at 20.6 m/min for a measuring wheel of diameter 200 mm at the current rate of rotation.

Rewinder Operat. function

- Settings: [*On*, *Off*]
- On: Normal operation - the internal backing paper rewinder is enabled.
- Off: The internal backing paper rewinder is disabled. Application example: Application of an external rewinder.

Tandem Operation function

- Settings: [*Off*, *Master*, *Slave*, „*FlipFlop master*“]
- Off: Tandem Operation is disabled.
- Master: The first machine products on the conveyor belt reach. In classic master-slave mode, the slave machine replaces the master only for the short time, until an error at the master machine is eliminated.
- Slave: The second machine products on the conveyor belt reach
- „*FlipFlop master*“: The first machine products on the conveyor belt reach. In Flipflop mode, the slave machine stays active until it is stopped by an error.

Tandem startmode function

- Application of a separate start sensor for master and slave increases the dispense accuracy.
- Settings: [„*1 Start sensor*“, „*2 Start sensors*“]
- „*1 Start sensor*“: One common start sensor is used for master and slave (connected via y-cable).
- „*2 Start sensors*“: Master and slave machine both have a separate start sensor. The start offset has to be set at each machine separately (LABEL SETUP > Start offset).

Tandem synchron. function

- To choose the interface via which tandem operation is synchronised
- Settings: [*None*, „*Serial Com1*“, „*UDP Tandem Port*“]
- None*, „*Serial Com1*“, „*UDP Tandem Port*“: No tandem operation (together with Tandem Operation = „*Off*“).
- „*Serial Com1*“: Tandem synchronisation over Com1 (INTERFACE PARA > EASYPLUGINTERPR > Interface function must not be set to „*Serial Com1*“ or to „*Automatic*“).
- „*UDP Tandem Port*“: Tandem synchronisation over Ethernet.

Slave IP address function

- Input of the IP address of the slave if tandem synchronisation over Ethernet is selected.
- Appears only if MACHINE SETUP > Tandem Operation = „*Master*“ or „*FlipFlop master*“ and if MACHINE SETUP > Tandem synchron. = „*UDP Tandem Port*“.
- Type in the IP address according to the scheme xxx.xxx.xxx.xxx.
- Setting range for each xxx-value: [0...255]; default: 0

Ready Mode Slave

- Affects the behavior of the ready signal on the slave machine
- Settings: [*Continuierlich*, *Berücksichtigen*]
- Continuierlich*: The ready signal on the slave machine is active when the master machine is ready
- Berücksichtigen*: The ready signal on the slave machine is *not* active when the master machine is ready (Default handling since firmware version 2.60)

Tandem Distance function

- Distance between the dispensing edges of master machine and slave machine

- Adjustment range: [100...1500] mm; default: 500

Label sens. type function

- Type of photoelectric label sensor
- Settings: [*Optical*, *Capacitiv*]
 - Optical: Throughbeam photoelectric sensor for transparent backing material
 - Capacitiv: Capacitive or other alternative label sensor

Labelsens. InType function

- Input type of the alternative label sensor (*not* valid for the standard (Wenglor) photoelectric label sensor)
- Settings: [*NPN*, *PNP*]

Startsen. In.Type function

- Product sensor input type
- Settings: [*NPN*, *PNP*]

Start disp. mode function

- Defines either the rising or falling side of the start signal peak as the point when dispensing is triggered.
- Settings: [*„Pulse falling“*, *„Level low active“*, *„Pulse rising“*, *„Level high activ“*, *„Pulse fall/ris“*]
 - “Pulse falling”: Dispensing a label is triggered by a change from high to low at the "sensor signal" input.
 - “Level low active”: Setting is only visible in production mode. Labels are dispensed for as long as the signal at the "sensor signal" input remains at the value low.
 - “Pulse rising”: Dispensing a label is triggered by a change from low to high at the "sensor signal" input.
 - “Level high activ”: Setting is only visible in production mode. Labels are dispensed for as long as the signal at the "sensor signal" input remains at the value high.
 - “Pulse fall/ris”: Dispensing a label is triggered both by a change from low to high and by a change from high to low at the "sensor signal" input.

Start error stop function

- Refers to the standard product start input (M12 connector), see chap. [Start \(product\) sensor](#)  on page 61.
- Determines how the machine reacts to a product start error. A product start error occurs whenever a further start signal is received before the current dispensing process is finished (LABEL SETUP > Product length = 0) respectively before the product with the set length has „passed by“ (LABEL SETUP > Product length > 0).
- Settings: [*On*, *Off*, *„Off label queued“*]

On: A start error is followed by the error message:

```
Status num:5009
Start error
```

The machine stops.

Off: A start error is followed by the warning:

ONLINE
Productstartwarn

The machine continues labelling. The warning can be set back by Easy-Plug command #!CL-RW.

„Off label queued“: Too early start signals are queued. They are processed, as soon as the machine is idle again.

On inhibit enter function

- „On entering inhibit“ means „after the inhibit signal has been applied“



„Inhibit“ is an input signal, which suppresses incoming start signals, what means, that start signals are being ignored as long as „Inhibit“ is active. Nevertheless, incoming start signals are being registered. Registered products are products, which find themselves between start sensor and dispensing edge.

- The function only affects the inhibit input at the standard signal interface in PLC mode. The inhibit input at the optional applicator interface is not affected.
- The function determines, how products are handled, which already had passed the start sensor, as the inhibit signal applied. The start signals triggered by the products are registered in a queue.
- For details about the effect of the function, read chapter [Impact of the inhibit signal](#) on page 214.
- Settings: [„Do regist starts“, „Del regist strts“]
 „Do registered starts“: The queue is not touched. Registered products are labelled.
 „Delete registered starts“: The queue is deleted. Any started labelling cycle is finished.

On inhibit leave function

- „On leaving inhibit“ means „after the inhibit signal stopped“
- The function only affects the inhibit input at the standard signal interface in PLC mode. The inhibit input at the optional applicator interface is not affected.
- The function determines, how products are handled, which already had passed the start sensor, as the inhibit signal stopped. The start signals triggered by the products are registered in a queue.
- Settings: [„Do saved starts“, „Del saved starts“]
 „Do saved starts“: Registered products are being labelled as soon as the first product reaches the dispensing edge.
 „Del saved starts“: The queue is deleted. Incoming start signals are registered.

Turn-on mode function

- Mode the machine is in after being switched on
- Settings: [*Online*, Offline, Standalone]
 Online: Labelling mode
 Offline: mode for adjusting settings
 Standalone: This mode is used for loading firmware (see chap. [Loading Firmware](#) on page 130) or configurations (see chap. [Saving/loading a configuration](#) on page 136) from memory card.

Language function

- Language of display text

- Settings: [German, *English*, French, Spanish, Dutch, Danish, Italian, Polish, Turkish, Russian, Czech, Japanese, Chinese]
- Chinese: Not all display texts are translated into chinese. Not translated texts are displayed in english]

Access authoriz. function

- Limits access to functions from the menu. Changes only come into force the next time the machine is switched on.
- Settings: [„User auto“, Supervisor, User, „Power-up code“, *Off*]

„User auto“: Machine starts in user mode.

Supervisor: Activates password check when the machine changes from offline mode to the parameter menu. Valid buttoncodes: Supervisor, Production.

User: Same as the “Supervisor” setting, except for the valid buttoncodes. Valid buttoncodes: All

„Power-up code“: Activates password check as soon as machine is switched on. Once a valid buttoncode has been entered, the machine switches to Offline mode. The machine is then in either User, Supervisor or Production mode, depending on which buttoncode was entered.

Off: Password check deactivated

Mode	Buttoncode
User	
Supervisor	
Production	

[Tab. 12] Valid buttoncodes

Mode	Effect
User	Access to the LABEL SETUP and SERVICE DATA menus
Supervisor	Access to all functions except production functions (indicated in the overview)
Production	Access to all functions

[Tab. 13] Effects of the different modes

CAUTION!
 Improper use of the special functions only accessible in production mode can damage the labeler or stop it from functioning.
 → Settings in production mode should only be adjusted by a trained servicing technician.

Materialend err function

- Refers to the internal OD control.
- Settings: [Off, „Mat.diam < x mm“]
- Setting range for x = [40,0...500,0]
- Default setting: x = 60

Deactivating the function:

→ Set x < 40.

Re-activating the function:

→ Press the button.

Defines the diameter threshold for the material roll. If the (calculated) material roll diameter is below the threshold value, the following *status message* appears:

Status num:5071
Material end unw

An additional material end error is caused, if no unwinder rotation is detected during at least 600 mm of material feeding:

Status num:5072
Material end unw

Materialend warn function

- Refers to the internal OD control.
- Settings: [Off, „Mat.diam < x mm“]
- Setting range for x = [40,0...500,0]
- Default setting: x = 80

Deactivating the function:

→ Set x < 40.

Re-activating the function:

→ Press the  button.

Defines the diameter threshold for the material roll. If the (calculated) material roll diameter is below the threshold value, the following *warning* appears:

ONLINE
Material low

Rewinder full function

Defines the maximum permissible diameter of the wound backing paper on the backing paper rewinder. If the diameter is exceeded, the following status message appears:

Status num:5064
Rewinder full

- Setting range: [50...500] mm; Default setting: 202 mm

Ext. OD sensor function

- Refers to the external OD light barrier (option).
- Settings: [Off, Warning, Error]

Off: OD sensor is disabled.

Warning: OD sensor is enabled. If the outer roll diameter is less than the critical value, the signal output „Warning“ is activated.

Error: OD sensor is enabled. If the outer roll diameter is less than the critical value, the signal output „Error“ is activated. Additionally, the status message „OD Material end“ appears.

OD Sens.polarity function

- Refers to the external OD light barrier (option).
- Sets the polarity of the OD sensor.
- Appears only if MACHINE SETUP > Ext. OD sensor = „Error“ or „Warning“
- Settings: [„Level low active“, „Level high activ“]
„Level low active“: Warning is displayed, if the sensor signal is low.

„Level high activ“: Warning is displayed, if the sensor signal is high.

INTERFACE PARA menu

Submenu >EASYPLUGINTERPR

Interface function

- Setting the active data interface
- Settings: [USB, Automatic, „TCP/IP SOCKET“, „Serial Com1“]

USB: USB 1.1 Interface.



USB IDs:

Machine	ID
ALS/XLS 204	0x204
ALS/XLS 206	0x206
ALS/XLS 209	0x209
ALS/XLS 256	0x256
ALS/XLS 272	0x202

Automatic: All interfaces can receive data, although *not simultaneously* .

“TCP/IP SOCKET”: Data can be sent via a TCP/IP socket to the Ethernet interface.

“Serial Com1”: Serial interface Com1.

CAUTION!

To avoid malfunctions:

→ Do not send data to more than one interface at any one time.



During tandem operation, Com1 is used for communication between master and slave machine. Therefore, the interface function may not be set to „Automatic“ or to „Serial Com 1“.

Dispenser ID no. function

- Labeler identification number
- Adjustment range: [0...31]
- Sets the identification number of the labeler. The labeler can then be called with the interface command: #!An (n=labeler ID). Setting up ID numbers is particularly sensible for data transfer via RS422/485 interface, if more than one labeler is connected via a data link. Each of the labelers connected then only processes the data addressed to it using the “#!An” command

Spooler size function

- The size of the data buffer memory can be set to fit customer requirements.
- Adjustment range: [96...256] KBytes; default: 96; increment: 16

Submenu >COM1 PORT

Baud rate function

- Data transfer rate

- Settings: [300, 600, 1200, 2400, 4800, 9600, 19200, 38400, 115200] bit/s

No. of data bits function

- Settings: [7, 8]

Parity function

- The parity bit is used to check the data transfer. If the check reveals an error, a message is displayed accordingly. The setting must be the same for both transmitter and receiver. The normal set-up is for transfer without a parity bit.
- Settings: [Odd, Even, *None*, “Always zero”]
 - Odd: Odd parity. A parity bit is added in such a way that the total number of 1 bits is odd.
 - Even: Even parity. A parity bit is added in such a way that the total number of 1 bits is even.
 - None: No check bit.
 - “Always zero”: The check bit is always 0 (zero). For transmission and reception without parity checking.

Stop bits function

- Settings: [1, 2]

Data synch. function

- Settings: [*RTS/CTS*, *XON/XOFF*, *None*]
 - RTS/CTS: Data synchronisation by hardware
 - XON/XOFF: Data synchronisation by software
 - None: Handshake lines are not monitored



Frame error function

- Settings: [*Display*, *Ignore*]
 - Display: An error message is shown if frame errors occur during serial transfer.
 - Ignore: Frame errors are ignored, no error message is displayed.

Submenu >NETWORK PARAM.



General rules for entering addresses:

- To change to the next/previous alphanumeric character:
→ Press the  or  button.
- To confirm selection and move to the next position:
→ Press the  button.

Alternatively, inputting can be carried out via the WEB Server function.

- See chapter **Web server**  on page 124

IP Addressassign function

- Settings: [“Fixed IP address”, DHCP]
 - “Fixed IP address”: This setting activates the “Net mask” and “Gateway address” parameters (see below).
 - DHCP: The IP address is assigned automatically. The IP address assigned is shown briefly in the display while the system starts up.

IP address function

- Enter IP Address in the form xxx.xxx.xxx.xxx

- Possible range for each xxx value: [0...255]

Net mask function

- Enter address of the network mask in the form xxx.xxx.xxx.xxx
- Possible range for each xxx value: [0...255]
- default: Depends on the IP address set (it is recommended that you adopt the default value)

Gateway address function

- Enter address of the gateway in the form xxx.xxx.xxx.xxx
- Possible range for each xxx value: [0...255]
- 000.000.000.000 = no gateway address used

Port address function

- Adjustment range: [1024...65535]; default: 9100

Ethernet speed function

- Settings: [Automatic, "10M half duplex", "10M full duplex", "100M half duplex", "100M full duplex"]
Automatic: The transfer rate is set automatically.
"10M Half duplex": Transfer rate = 10 MBit/s with *half duplex* operation.
"10M full duplex": Transfer rate = 10 MBit/s with *full duplex* operation.
"100M Half duplex": Transfer rate = 100 MBit/s with *half duplex* operation.
"100M full duplex": Transfer rate = 100 MBit/s with *full duplex* operation.

MAC Address function

- Displays the MAC address of the CPU Board.
- This address cannot be altered via the menu.

DHCP host name function

- Host name of the labeler.
- default: "Device Name" + the last 3 characters of the MAC address
- Permitted characters: A-Z, a-z, 0-9, -

FTP server function

- The file transfer protocol (FTP) server (RFC959) enables access to the labeler's internal RAM disk and to the compact flash card if one is in place. The FTP server is multisesion compatible, in that the user name given when logging in is not verified. The password must match the FTP password set (see below).
- Settings [Enabled, *Disabled*]
Enabled: The FTP server is switched on.
Disabled: The FTP server is switched off.
- See chapter **FTP server**  on page 128

FTP Password function

- To input the password for the FTP server. default: novexx

WEB server function

- The web server makes it possible

- to set or read the values of functions from the menu via a web browser
- to control the operator panel of the labeler via a web browser.
- See chapter [Web server](#)  on page 121

WEB admin passw. function

- Changes the admin password for the web server
- default: “admin”
- Access rights to functions are equivalent to those in supervisor mode (see MACHINE SETUP > Access authoriz.)

WEB supervisor p. function

- For changing the supervisor password for the web server
- default: “supervisor”
- Access rights to functions are equivalent to those in production mode (see MACHINE SETUP > Access authoriz.)

WEB operator p. function

- For changing the operator password for the web server
- default: “operator”
- Access rights to functions are equivalent to those in production mode (see MACHINE SETUP > Access authoriz.)

SIGNAL INTERFACE**Interface mode function**

- Sets the operation mode of the standard signal interface.
- Settings: [„PLC signals“, „Applic. signals“]
 „PLC signals“: The signal interface provides PLC signals.
 „Applic. signals“: The signal interface provides signals for applicator control.

Submenu >PLC SIGNALS

Only appears, if SIGNAL INTERFACE > Interface mode = „PLC signals“.

End dispense mod function

- Affects the output signal „Dispense End“ at the signal interface. Defines the signal response.
- Settings: [„Mode0 inactive“, „Mode1 low level“, „Mode2 high level“, „Mode3 low pulse“, „Mode4 high pulse“]
 „Mode0 inactive“: Signal is disabled
 Meaning of the other settings: see chapter [Signals for PLC connection](#)  on page 212.

Disp.end delay function

- Sets the delay of the „Dispense End“ signal after the feed motor stopped.
- Setting range: [0...10000] ms.
- See chapter [Signals for PLC connection](#)  on page 212.

End pulse width function

- Sets the duration of the „Dispense End“ signal.

- Setting range: [0...10000] ms.
- See chapter **Signals for PLC connection**  on page 211.

Submenu >APPLIC. SIGNALS

Only appears, if SIGNAL INTERFACE > Interface mode = „Applic. signals“.

Applicator type function

- If an applicator is used to attach the labels, the applicator type is set here. Alternatively, “Direct Dispense” should be selected to dispense without an applicator.
- Settings: [„LTP - LTPV“, PEP, „PEP Blow on“, „PEP II Sensor“, ASA, „Reverse PEP“, „Direct Dispense“, „BTS“, „O-ring applicat.“, „LA-BO“, „LA-TO Timed“, „LA-TO Sensor“, „LA-TO BO Timed“, „LA-TO BO Sensor“]

“LTP - LTPV”: Sensor controlled tamp-on applicator. The movement of the pneumatic cylinder is limited by (touchdown-)sensors, which react to slight pressure onto the product. The LTPV additionally sucks the labels on with a vacuum nozzle.

PEP: The cylinder movement is limited by a setable length of time. After the run out of this application time, the applicator moves back into home position

“PEP Blow on”: PEP-type applicator with blow on function: After run out of the application time, the blow on function is activated. After run out of the blow on time, the applicator moves back into home position

“PEP II Sensor”: The cylinder movement is limited by a (touchdown-) sensor, which signals the contact to the product and triggers the backwards-movement.

ASA: Vintage applicator. Same function as LA-BO.

“Reverse PEP”: Combined tamp-on/blow-on applicator. The applicator moves to its end position and “waits” for the start signal. The start signal triggers the blow on valve which is active for the defined blow on time. After the run out or the blown on time, the applicator moves to home position, gets the next label and moves to the wait position.

“Direct Dispense” Labelling *without* an applicator

“BTS”: Setting for operation with Bad Tag Separator, an additional unit that removes “bad” RFID labels before they are dispensed.

“O-ring applicat.”: Vintage applicator.

LA-BO: Blow-on applicator. The label is moved by airstream over a short distance onto the product.

„LA-TO Timed“: Setting for a time-controlled LA-TO. Same function as PEP.

„LA-TO Sensor“: Sensor-controlled tamp-on applicator.

„LA-TO BO Timed“: Setting for time-controlled LA-TO BO.

„LA-TO BO Sensor“: Setting for sensor-controlled LA-TO BO.



For information about the signal wave forms see chapter **Signal wave forms of applicator signals**  on page 203.

For information about the applicator function refer to the relevant applicator service manual.



Depending on the selected applicator type appear different setting functions for the applicator .

Applicators	Functions			
	Dwell time	Blow on time	Restart delay	Position timeout
LTP - LTPV		X	X	X
PEP	X		X	X
PEP Blow on	X	X	X	X
PEP II Sensor		X	X	X
ASA		X	X	
Reverse PEP	X	X	X	X
None (Direct Dispense)			X	
BTS	X	X	X	X
O-ring applicat.		X	X	X
LA-BO		X	X	
LA-TO Timed	X		X	X
LA-TO Sensor			X	X
LA-TO BO Timed	X	X	X	X
LA-TO BO Sensor		X	X	X

[Tab. 14] The appearance of those menu functions depends on the selected applicator type (x = function appears).

Status outputs function

- Determines the output signals at pin 7 and 8 at the signal interface.
- Settings: [Off, On]
 - Off: Assignment of applicator signals (pin 7 = vacuum, pin 8 = blow on)
 - On: Assignment of status signals (pin 7 = dispense end, pin 8 = warning)

Apply mode function

- Determines whether the application process begins with application (“after start sig.”) or dispensing (“after dispensing”) of a label.
- Settings: [“After dispensing“, „After start sig.“]
 - “After dispensing”: The start signal triggers both the dispensing and the application of a label.
 - “After start sig.”: The start signal triggers the application of a label that has already been dispensed. The next label is then dispensed immediately after application.

Dwell time function

- Appears only if SIGNAL INTERFACE >APPLIC. SIGNALS > Applicator type = PEP, „PEP Blow on“, „Reverse PEP“; BTS or „LA-TO Timed“
- Determines the length of time for which the applicator is extended
- Is required for applicators that are not limited by a touch-down signal
- Dedicated signal output: Pin 5 at the signal interface

- Adjustment range: [1...99999] ms; default: 200 ms (LA-TO Timed: 500 ms)

Blow on time function

- Appears only if SIGNAL INTERFACE >APPLIC. SIGNALS > Applicator type = „PEP Blow on“, ASA, „Reverse PEP“, BTS, „O-ring applicat.“ or LA-BO
- Sets the duration for blowing on of each label
- Only appears when an applicator that requires blowing on is used (e.g. “PEP Blow on”)
- Dedicated signal output: Pin 8 at the signal interface
- Adjustment range: [0...99999] ms; default: 50 ms (LA-BO: 60 ms)

Restart delay function

- Determines the length of time after application for which no start signals will be accepted.
- Adjustment range: [0...99999] ms; default: 0 ms

Position timeout function

- Does *not* appear, if SIGNAL INTERFACE >APPLIC. SIGNALS > Applicator type = ASA, „Direct Dispense“ or LA-BO
- Determines the length of time after which an applicator position error is displayed as an error. A position error is considered to have occurred if the applicator has failed to reach one or both of its end positions within the time set.
- Adjustment range: [500...99999] ms; default: 2000 ms

Apply comp. time function

- Compensation time for the applicator stroke time; required for operation with variable conveyor speed.
- Setting range: [0...99999] ms.

 Most applicators have a constant stroke time. If the labeler is driven with variable speed, this leads to different label positions on the product. With a slow conveyor speed, the touch down comes too early, with a high conveyor speed, it is too late. With the stroke time entered in the function Apply comp. time, the dispenser corrects this effect, and therefore improves the labelling precision.

When the compensation time is added, depends on the setting of the apply mode (see above):

- Apply mode = „After dispensing“: Compensation time is added after the „dispense end“ signal
- Apply mode = „After start sig.“: Compensation time is added after the start signal

Setting instruction:

- Setup the dispense-apply-process with a slow conveyor speed.
- Turn the conveyor speed high.
- Adjust the labelling position by increasing the Apply comp. time step by step, until the labelling position is correct.

Touch down sens. function

- Switching behaviour of the touchdown sensor.
- Settings: [„Pulse falling“, „Pulse rising“]
 „Pulse falling“: The *falling* signal edge at the sensor triggers the touchdown trigger event
 „Pulse rising“: The *rising* signal edge at the sensor triggers the touchdown trigger event

TouchDownTimeout function

- Timeout at the touchdown sensor. This time specifies the maximal wait time for the touchdown

trigger event.

- Settings: [„Off“, (100...99999) ms“]

Off: The function is switched off

xxxx ms: If the specified time xxxx mx is exceeded without the touchdown event, the applicator continues operation in the same manner as the touchdown event would have taken place. No error message will appear in this case.

Submenu >AI BOARD SIGNAL

This menu only appears, if an optional applicator interface (AI) is installed *and* if SIGNAL INTERFACE > Interface mode = „Applic. signals“. The functions in the menu refer to the AI.

Applicator type function

- See description of function SIGNAL INTERFACE >APPLIC. SIGNALS > Applicator type on Seite 73.

Apply mode function

- See description of function SIGNAL INTERFACE >APPLIC. SIGNALS > Apply mode on Seite 74.

Start mode function

- Selects a start mode. Depending on the selected mode, the start signal will be interpreted differently.
- Settings: [„Pulse falling“, „Level low active“, „Pulse rising“, „Level high activ“, „Pulse fall/ris“]

„Pulse falling“: The dispensing of a label is triggered by a high-low-change of the start signal. The dispensing occurs only after the set delay time.

„Level low active“: Labels are being dispensed as long as the start signal is held low.

„Pulse rising“: The dispensing of a label is triggered by a low-high-change of the start signal. The dispensing occurs only after the set delay time.

„Level high activ“: Labels are being dispensed as long as the start signal is held high.

„Pulse fall/ris“: The dispensing of a label is triggered by a low-high-change as well as by a high-low- change of the start signal. The dispensing occurs only after the set delay time.

Dwell time function

- See description of function SIGNAL INTERFACE >APPLIC. SIGNALS > Dwell time on Seite 74.

Blow on time function

- See description of function SIGNAL INTERFACE >APPLIC. SIGNALS > Blow on time on Seite 75.

Restart delay function

- See description of function SIGNAL INTERFACE >APPLIC. SIGNALS > Restart delay on Seite 75.

Position timeout function

- See description of function SIGNAL INTERFACE >APPLIC. SIGNALS > Position timeout on Seite 75.

Apply comp. time function

- See description of function SIGNAL INTERFACE >APPLIC. SIGNALS > Apply comp. time on Seite 75.

Touch down sens. function

- See description of function SIGNAL INTERFACE >APPLIC. SIGNALS > Touch down sens. on Seite 75.

TouchDownTimeout function

- See description of function SIGNAL INTERFACE >APPLIC. SIGNALS > TouchDownTimeout on Seite 75.

Submenu >AI BOARD SIGNAL

This menu only appears, if an optional applicator interface (AI) is installed *and* if SIGNAL INTERFACE > Interface mode = „PLC signals“. The functions in the menu refer to the AI.

Status signals function

- Switches the signal outputs at the AI on or off
- Settings: [Off, On]
 - Off: The AI is completely disabled
 - On: The applicator control of the AI is disabled. Enabled are the status outputs at the „machine status“ connector and the „Airstream support“ output at the applicator connector.

Submenu >ACTIVE INPUTS

In this menu, the active input signals can be selected, if there are identical input signals at different interfaces. This can e. g. be the case with some signals at standard signal interface and optional applicator interface (AI).

Start signal function

- Settings: [„Default input“, „Opt. appl.interf“].
 - „Default input“: Activates the standard start signal input (M12 connector).
 - „Opt. appl.interf“: Activates the start signal input at the optional applicator interface. Setting appears only with the optional AI board built in.

Inhibit signal function

- Settings: [„Default input“, „Opt. appl.interf“].
 - „Default input“: The Inhibit signal input at the standard signal interface is active.
 - „Opt. appl.interf“: The Inhibit signal input at the optional applicator interface is active.

OD sensor signal function

- Settings: [„Default input“, „Opt. appl.interf“].
 - „Default input“: The standard OD sensor signal input (M12 connector) is active.
 - „Opt. appl.interf“: The OD sensor signal input at the optional applicator interface is active.
- Conditions:
 - This setting only appears if an applicator interface is installed.
 - MACHINE SETUP > Ext. OD sensor must be set to „Warning“ or „Error“.
 - MACHINE SETUP > OD Sens.polarity is overridden.

SERVICE/DIAGNOS. menu

Service function

- Counter for service operations
- Settings: [Yes, No]
 - Yes: Increments the “Serv. operations” counter by one (see SERVICE DATA >OPERATION DATA > Service operations)

No: Does not increment the counter.

Serv. data reset function

- Settings: [Yes, No]
Yes: Sets all counters in the SERVICE DATA menu to zero.
No: Counts remain unchanged

Sensor Test function

- See chapter **Sensor test**  on page 255

PS registers function

- By means of this parameter, the register contents of the power supply can be changed
- Appears only in production mode
- Parameter only for authorised, trained service personnel

Memory card test function

- Test function for compact flash cards
- Pressing the Online button starts a test routine for the compact flash card memory. After a successful test, the following is displayed:

```
Memory card test
Card Test O.K.
```

If the compact flash card is faulty or not in place, an appropriate error message is displayed.

Test functions function

- Starts motor durability test: Both motors start and stop continually at short intervals
- For use at the factory

Store diagnosis function

- Stores the diagnostic data on memory card.
- The default file name composes as follows:
„Diagnose ALS 306 RH A637804070501067.log“
ALS 306 RH = device type
A637804070501067 = Serial number of the CPU board; equals the value displayed under SERVICE DATA > CPU BOARD DATA > Serial number

Gen.Support Data function

Generate support data

Generates the folder „SupportData“ on the selected memory medium and stores the following diagnosis files therein:

- Setup.for (for details see SPECIAL FUNCTION > Store Parameters)
- SetupAll.for (for details see SPECIAL FUNCTION > Store Parameters)
- Diagnose.log (for details see SPECIAL FUNCTION > Store diagnosis)

Each of the file names is completed by the printer type and the serial number of the CPU board. The file content is english, regardless of the language setting at the printer.

Those data are very helpful for the technical support for fault diagnosis purposes.

Data blocks del. function

- Deletes one or all data blocks in the flash memory.

- Appears only, if at least one data block is in the flash memory.
- Settings: [Bxx, All]

Bxx: Deletes block number xx.

After calling the parameter, data block number 01 is displayed:

```
Data blocks del.
B01 diagnose inf
```

„B01“: block number 01.

„diagnose inf“: name of the data block; is contained in the data block header.

If the flash memory contains more than one data block:

- Press the cut button several times, until the wanted data block appears.

Deleting a data block:

- Press the online button.
- Press the feed button to change to „yes“.
- Press the online button to delete the block.

```
Data blocks del.
Delete? --> no
```

All: Deletes all blocks

SERVICE DATA menu



If the text shown is longer than the display line length:

- Press the button to move the text to the left.
- Press the button to move the text to the right.

Submenu >MODULE FW VERS.

System version function

- Shows the firmware version of the labeler

System revision function

- Shows a consecutive revision number.
- Only for factory-internal purpose.

System date function

- Shows the date, at which the firmware was generated.

Bootloader function

- Shows the bootloader version number.

uMon function

- Shows the micromonitor version number.
- Only for factory-internal purpose.

Applicator int. function

- Shows the firmware version of the applicator interface:

Applicator int.
V 1 – T 17

V1 – T17 means firmware version 1.17.

Submenu >OPERATION DATA

Service operations function

- Shows the total number of services that have been carried out.
- Increment the counter by using SERVICE/DIAGNOS. > Service
- Maximum value: 4 Bn.

Tot. mat. length function

- Displays the total material length that has been fed, i.e. the "mileage" of the drive roller.
- Maximum value: 4 Bn. metres

Dispensing cycl. function

- Counter for the number of labels dispensed.

Operation time function

- Displays the total running time of the machine since it was last powered up.

Total Operation function

- Displays the total running time of the machine since it was first powered up.

Submenu >POWERSUPPLYDATA

Type function

- Displays the type of power supply.

Version function

- Shows the power supply version.

Serial number function

- Shows the power supply serial number.

PS Temperature function

- Shows the temperature of the power supply in °C.

Standby+On time function

- Shows the total time, during which the power supply was switched on.

Submenu >CPU BOARD DATA

CPU identifier function

- Displays the identification of the processor used

PCB Revision function

- Displays the layout revision and part number of the CPU board

FPGA version function

- Displays the FPGA version

MAC Address function

- Displays the MAC address, an address for the board which is programmed by the manufacturer and cannot be changed

Serial number function

- Displays the serial number, which is programmed in by the board manufacturer

Production date function

- Displays the date of manufacture of the CPU board

PCB part number function

- Displays the part number of the board without components

Board part numb. function

- Displays the part number of the board complete with components

Manufacturer function

- Displays the manufacturer of the board

Work place function

- Displays the work place of the labeler

Company name function

- Displays the company name

Submenu >DISPLAY DATA**Display Version function**

- Displays the version of the operator panel.

Display serialNr function

- Shows the serial number of the operator panel.

Remote disp.vers function

- Shows the version of the remote operator panel.

Remote disp. ## function

- Shows the serial number of the remote operator panel.

Submenu > PERIPHERAL DATA**Applicator int. function**

- Function only appears when there is an applicator interface installed
- Shows the PCI model of the applicator interface

Submenu >MEMORY DATA

RAM memory size function

- Shows the size of the available RAM

Flash mem size function

- Shows the size of the available flash memory

Custom defaults function

- Shows, if custom default settings are stored (displays „Yes“ or „No“, see MACHINE SETUP > Custom defaults)

Enhanced Functions

ACCESS VIA A WEB/FTP SERVER

Web server

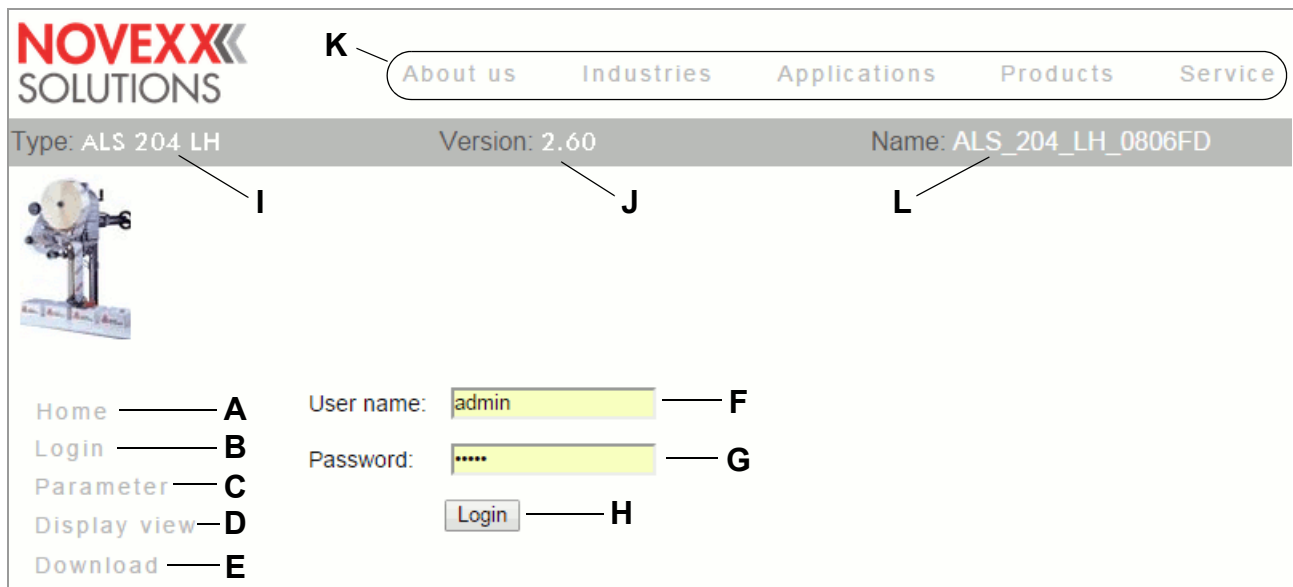

[82] User interface of the web server (after clicking on "Login")

- A** Link to the web server home
- B** Opens input fields for user name and password [82]
- C** Calls the function menu
 - Enables settings in the labeler function menu to be changed.
- D** Calls the operator panel display
 - Gives access to all the functions of the real operator panel
- E** Starts the FTP server in a new browser window
 - See chapter **FTP server**  on page 87
- F** Input field for user name
 - Preset: "admin"
- G** Input field for password
 - Preset: "admin"
 - The password can be changed under INTERFACE PARA >NETWORK PARAM. > WEB server
- H** Click on this button after entering user name and password
- I** Displays the machine model
- J** Displays the firmware version
- K** Links to the NOVEXX Solutions website
- L** DHCP host name (see INTERFACE PARA >NETWORK PARAM. > DHCP host name)

Applications

The web server makes it possible

- to set or read the values of functions from the function menu via a web browser
- to control the operator panel of the labeler via a web browser.



The web server is *not* multi-session compatible, i.e. only one user can be logged in at any time.

The web server is a setup utility, not an operational one. The web server should not be heavily used during a high performance application of the dispenser.

Prerequisites

- Labeler is connected to network
- A valid IP address is assigned to the dispenser (by the network administrator or by a DHCP server)
- INTERFACE PARA >NETWORK PARAM. > WEB server must be set to “Enabled”.
- Web browser installed on the host (e. g. Firefox, Internet Explorer, Chrome)

Starting the web server

- Note down the IP address of the labeler
- This is shown under INTERFACE PARA >NETWORK PARAM. > IP address
- Start internet browser.
- Enter the following in the address bar:
http://[IP address without initial zeroes]
- Example: IP address = 144.093.029.031
Enter: http://144.93.29.31

Logging in to the web server

- Click on the “Login” link [82B]
- Enter user name and password [82F, G]
- Preset in both cases: admin
- Click on the “Login” button [82H]

Changing a setting in the labeler menu

Click on the names of submenus and functions to open them so that you can change the settings they contain.

Example: Making a change to LABEL SETUP > Start offset:

- Click on “Parameter” link [82C].
- Click on “LABEL SETUP” link.
- Click on “Start offset” link.
- A dialog box opens: [83].
- Enter the required value in the entry field.
- Click on the “Save” button.

The value is now transferred to the labeler.

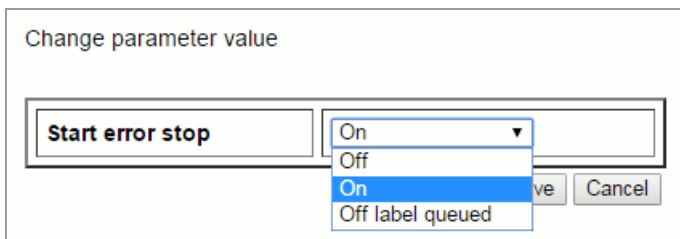

[83] Example: Dialog box for entering value for the function MACHINE SETUP > Startfehler Halt

i Some functions trigger a reset of the labeler, if they have been changed on the labeler via the operator panel. However, if any of these functions is changed via the web server, the reset does not occur automatically. The changes only come into effect after the next time the labeler is reset. In these cases, the “Reset” button [84A] appears after the setting has been changed.

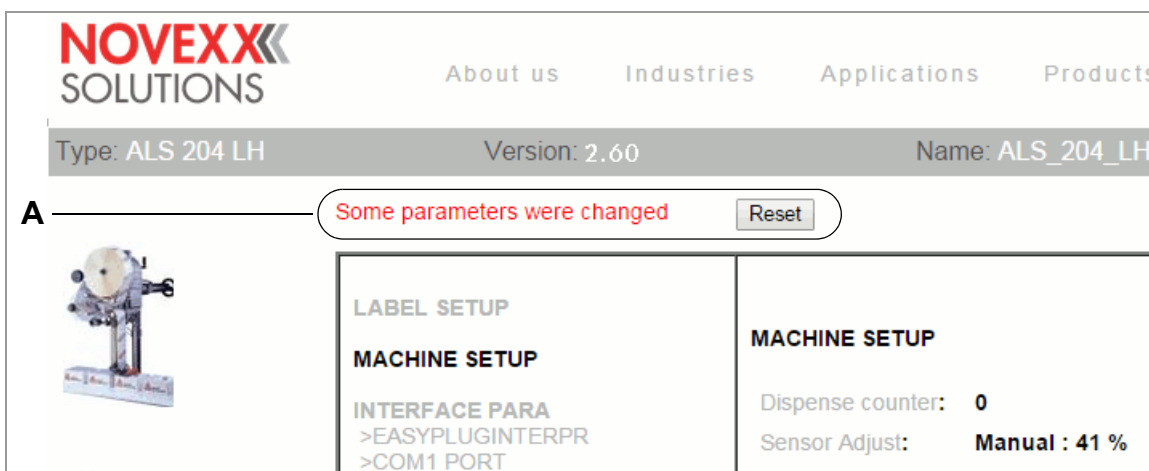

[84] Information (A): Changes made to the function setting do not come into effect until after a reset.

The virtual operator panel

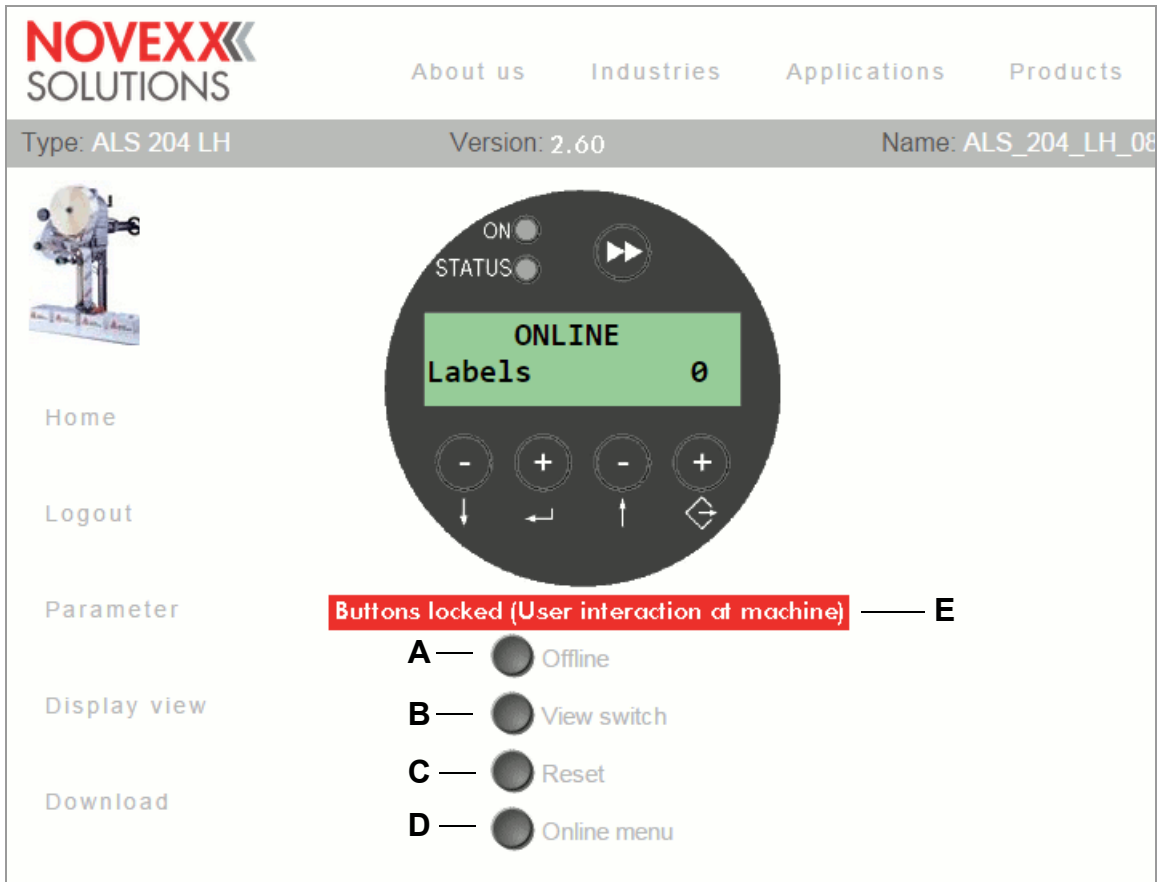

[85] The virtual operator panel

After the “Display view” link is clicked, an image of the labeler operator panel (= virtual operator panel) appears on the screen [85]. All of the buttons on the real operator panel can also be operated by mouse-click on the virtual operator panel.

The buttons [85A-D] underneath the virtual operator panel are equivalent to key combinations on the real operator panel

A “Offline” button

- Sets the machine offline during dispensing mode
- Equals pressing the

B “View switch” button

- Switches into standalone mode (required for loading firmware, see chapter **Loading from USB thumb drive** on page 128)
- Equivalent to the combination +

C “Reset” button

- Triggers a reset
- Equivalent to the combination + +

D „Online Menü“ button

- Changes to „Dispensing mode“ > „Online settings“ (- button) or back to „Dispensing mode“ (buttons +).

FTP server

Applications

The file transfer protocol (FTP) server (RFC959) enables access to the labeler's internal RAM disk and to the compact flash card in the card slot of the labeler (as long as there is a compact flash card in the slot).

In this way, files (configuration or firmware files) can be saved to the CF card or the internal RAM disk, or existing files renamed or deleted.

-  The FTP server is multi-session compatible.
- The FTP server should not be heavily used during a high performance application of the labeler.

Prerequisites

- Labeler is connected to network
- A valid IP address is assigned to the dispenser (by the network administrator or by a DHCP server)
- INTERFACE PARA >NETWORK PARAM. > FTP server must be set to “On”.
- FTP client is installed on the host computer (e. g. WS-FTP, Windows Explorer, Internet Explorer, Midnight Commander).
- The FTP connection is *not* blocked by a firewall

Establishing a FTP connection

- Note down the IP address of the labeler
- This is shown under INTERFACE PARA >NETWORK PARAM. > IP address
- Start the FTP client.
- Enter the following in the address bar:
 - ftp://[IP address without initial zeroes]
- Example: IP address = 144.093.029.047
Enter: ftp://144.93.29.47

An input field for the user name and password appears.

- Enter user name and password.
- A user name can be chosen at will; preset password = “novexx”
- Change the password under INTERFACE PARA >NETWORK PARAM. > FTP Password

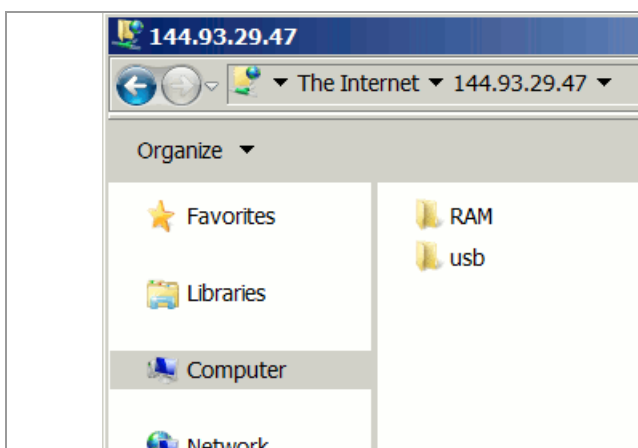

[86] User interface of the FTP server in the Windows Explorer. RAM = internal machine memory; usb = connected USB stick.

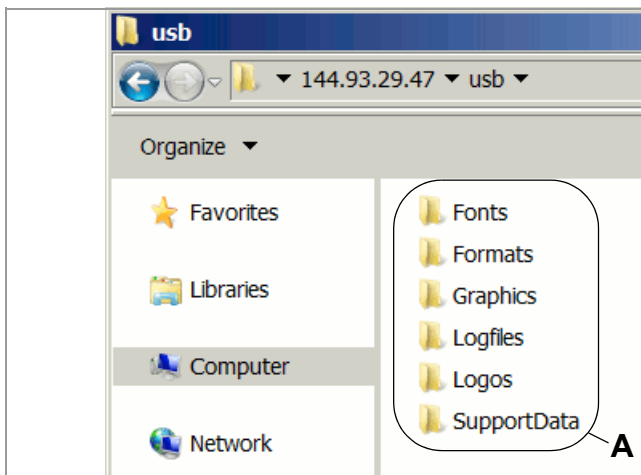

[87] Folders on the USB stick (A).

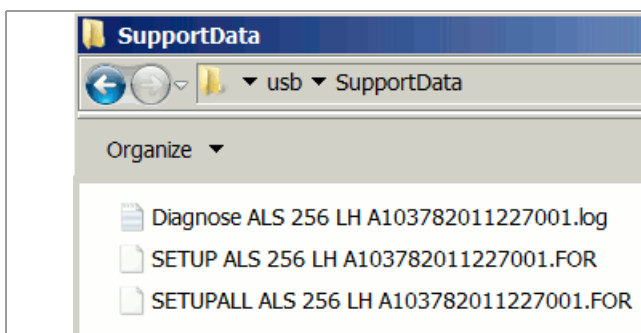

[88] Files in folder „SupportData“.

If the login was successful, separate folders appear in the FTP client, one for the internal RAM disk and one for each connected memory medium [86]:

- RAM:
The content of the RAM disk is without matter for the user.
- USB:
If one of the functions for storing setup or diagnosis data on a memory medium was already processed, the following subfolders can be found here ¹:

Subfolder	Comment
Formats	Location for setup files (see MACHINE SETUP > Store Parameters) Location for firmware files to be uploaded in standalone mode.
Logfiles	Location for diagnosis files (see SERVICE/DIAGNOS. > Store diagnosis)
SupportData	Location for setup and diagnosis files (see SERVICE/DIAGNOS. > Gen.Support Data)
Fonts	Without function
Graphics	
Logos	

1) Depending on the applied memory medium appears SD, CF or USB.

SAVING/LOADING A CONFIGURATION

Applications

It sometimes happens that all of the parameter settings for a labeler must be restored or transferred to another labeler. In such cases, the user can import all of the function settings together as a set, saving time, money and stress. The following applications come to mind:

- After a service action, when the same settings as before the service are to be reinstalled on a labeler.
- When the settings in the functions menu of one labeler are to be transferred onto another machine of the same model.
- When several labelers of the same model are to be set up with exactly the same settings.

In these cases, it is convenient to first export and save the settings so that they can later be imported. There are two ways of doing this:

- Data interface: Readout via the data interface with the help of appropriate interface commands. This method requires a sound knowledge of the Easy Plug command language and will not be described here (for detailed information see the Easy Plug manual).
- External memory medium: Saving the settings onto a memory medium as a text file (“setup file”) (see description that follows).



For details about applying external memory media refer to the „External memory media manual“.

Saving onto an external memory medium

- Switch the labeler off.
- Connect a memory medium to the USB connector.
- Switch the labeler on.
- Call MACHINE SETUP > Store Parameters
 - This function only appears in the menu if there is a memory card in the labeler’s card slot.
- Choose an option for saving: “With adjust para” or “Without adj. par”
 - “With adjust para”: (Preset): device-specific settings are *included* in what is saved. These include sensor settings, for example.

The names of the relevant functions are marked with a “*” in the text file.

This setting is recommended when the intention is to transfer the settings back onto the same machine.
 - “Without adj. par”: parameters that contain device-specific settings are *excluded* from what is saved.

This is recommended when settings from one machine are to be transferred to another machine of the same model.
- Press the  button.
 - The preset file name is now shown (saved in \FORMATS directory on the memory medium):

“SETUPALL ALS xxx yy zzzzzzzzzzzzzzzzzzzzz.FOR” for MACHINE SETUP > Store Parameters = “With adjust para”

“SETUP ALS xxx yy zzzzzzzzzzzzzzzzzzzzz.FOR” for MACHINE SETUP > Store Parameters = “Without adj. par”

(with xxx = machine type, e. g. 306; yy = RH or LH; zzzzzzzzzzzzzzzzzzzzz = CPU board serial number)



File name and directory can be changed using buttons on labeler operator panel. If a file with the name entered already exists, this will be overwritten without asking for confirmation.

Loading from an external memory medium

Selecting a file

- Press the + buttons simultaneously.
- Display:

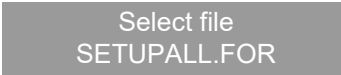

Files with the following endings can be selected:

- “.FOR” (configuration file) or
- “.S3B” (firmware file).

The files must be located on the compact flash card, in the “\FORMATS” directory.

If there is more than one file in the “\FORMATS” directory, the first file alphabetically is displayed. The following system is used to select a file:

Button	Action
	Show next file
	Show previous file
	Show first file
	Select currently displayed file

[Tab. 15] Functions of buttons for file selection

Once a file has been selected, it is executed. If a configuration file was selected, the configuration is loaded. For a firmware file, the firmware starts loading.

If there are no suitable files in the “\FORMATS” directory or no memory medium is connected, the following message appears:

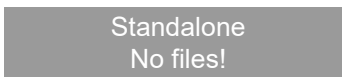

Loading procedure

- Select file as described above.
- Press the button.
- Display:

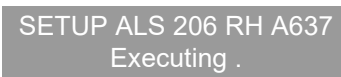

(Top line = selected file name)

The loading can take a couple of seconds. To visualize the progress, the point is moving during the loading.

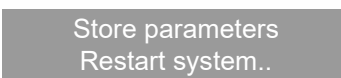

The configuration is loaded after the restart.

Automatic loading

→ Save the configuration file as \AUTOSSETUP.FOR (in the memory medium root directory)

Importing the settings:

→ Switch labeler off

→ Insert memory card

→ Switch labeler on

The import of the function settings starts automatically. Display after settings have successfully been applied:

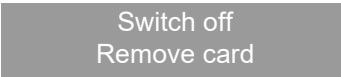



Switch off
Remove card

→ Switch labeler off

→ Remove memory card

Loading a configuration via the data interface

Prerequisites:

- A configuration file has been read out (see chapter [Saving onto an external memory medium](#)  on page 89).
- The configuration file was saved on the host computer (The transfer can be carried out using the FTP server, for example, see chapter [FTP server](#)  on page 128).
- The host computer and labeler are connected via *the* interface which has been activated through the menu: SCHNITTST. PARA > EASYPLUGINTERPR > Schnittstelle (Com1, USB or Ethernet)
- Host computer operating system: Windows XP, Windows 7 or Windows 10

Serial interface

On the host computer:

→ Open a command prompt window.

→ Enter the command `copy setupall.for com1` [89] (replace “setupall.for” with your filename)

→ Press the Enter key.

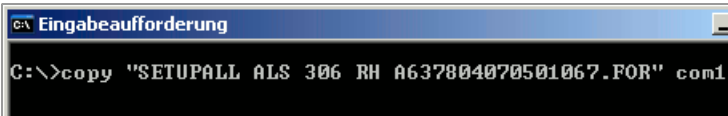

```

Eingabeaufforderung
C:\>copy "SETUPALL ALS 306 RH A637804070501067.FOR" com1

```

[89] Command prompt window showing the command to transfer the file “setupall.for” to the interface Com1.

USB/Ethernet interfaces

On the host computer:

→ Open a command prompt window.

→ Enter the command `copy setupall.for \\Computername\Share name` (replace “setupall.for” with your filename), where:

- Computername = Name of the computer. You can find this name in Windows XP under START > SETTINGS > CONTROL PANEL > SYSTEM > COMPUTERTNAME (e.g. “DM-ECH-0990”).
- Share name = name found in Windows XP under START > SETTINGS > PRINTERS AND FAXES, by right-clicking on the device icon then clicking PROPERTIES > SHARING. The Share name stands for a printer that is connected to a certain port – a USB port for transfer via USB or the TCP/IP port for Ethernet transfer.



Some tips about transfer via a USB or Ethernet interface:

- The procedure described does not work with Windows 98, Windows ME or Windows NT 4.0.
- The Share name must satisfy MS-DOS conventions (max. 8 characters length, no special characters or spaces)

Example of a printout from SETUPALL.FOR

```

#!A1
#G Machine Setup for ALS 256 LH      Version: V2.52
#G Serial number      : A103782011227001
#G MAC Address        : 000A.44.08.00.05
#G Creation date      : 01.01.2000 00:03

#G-----
#G LABEL SETUP
#G-----
#G PC2067/0           #G Gap detect. mode : Manual
#G PC6000/10.0        #G Dispense speed  : 10.0 m/min
#G PC6001/10.0        #G Slew speed      : 10.0 m/min
#G PC6002/100.0       #G Label pitch     : 100.0 mm
#G PC6003/19.0        #G Lab. stop offset : 19.0 mm
#G PC6004/15.1        #G Start offset    : 15.1 mm
#G PC6034/0.0         #G Start offset    : 0.0 mm
#G PC6017/0.0         #G Product length  : 0.0 mm
#G PC6035/0           #G Multi label mode : Off
#G PC6036/100.0       #G Label 2 offset  : 100.0 mm
#G PC6037/100.0       #G Label 3 offset  : 100.0 mm
#G PC6007/1           #G Miss. label tol. : 1
#G PC6041/0           #G Miss. label mode : Compensate
#G PC6015/0           #G Stop count. mode : Off
#G PC6016/0           #G Label stop quan. : 0
#G-----
#G MACHINE SETUP
#G-----
#G PC5050/4           #G *Dispenser type  : ALS 256 LH
#G PC2002/0           #G Speed unit       : Inch/s
#G PC2069/1           #G Cover open error : Immediately
#G PC2065/1           #G Param. data base : 1
#G PC2005/3           #G *Dispense counter : 3
#G PC2006/0           #G w/wo magazine   : with
#G PC2058/0           #G Feed mode        : Head up
#G PC2071/0           #G EasyPlug errors  : Tolerant handl.
#G PC2068/5           #G Foil stretching : Feedback: 5 mm
#G PC2043/0           #G Start print mode : Pulse falling
#G PC6005/0           #G Speed Adaption   : Off
#G PC6006/0           #G Encoder Type     : Single Phase
#G PC6008/500         #G Encoder Resol.   : 500 pulses/turn
#G PC6009/64.0        #G Encoder Diameter : 64.0mm 0.0var
#G PC6040/1           #G Rewinder Operat. : On
#G PC6046/1.64        #G Rewinder gear    : Reduction 1:1.64
#G PC6018/0           #G Tandem Operation : Off
#G PC6047/0           #G Tandem startmode : 1 Start sensor
#G PC6020/3           #G Tandem Synch.    : UDP Tandem Port
#G PC6038/0           #G Slave IP address : 000.000.000.000
#G PC6019/500.0       #G Tandem Distance  : 500.0 mm
#G PC2015/4           #G Label sens. type : Optical
#G PC6011/1           #G Labelsens. In.Type : PNP
#G PC6012/1           #G Startsen. In.Type : PNP
#G PC6013/0           #G Start disp. mode  : Pulse falling
#G PC6014/0           #G Start error stop  : Off
#G PC6042/0           #G On inhibit enter  : Do saved starts
#G PC6043/0           #G On inhibit leave  : Do saved starts
#G PC2020/1           #G Turn-on mode      : Online
#G PC2051/1           #G Language          : English
#G PC2053/0           #G Access authoriz.  : Off
#G PC2075/60          #G Materialend err   : Mat.diam < 60mm
#G PC2074/80          #G Materialend warn  : Mat.diam < 80mm
#G PC2076/202         #G Rewinder full     : Diameter > 202mm
#G PC6022/0           #G Ext. OD sensor    : Off
#G PC6028/0           #G OD Sens.polarity  : Level low active
#G PC6044/0           #G Loop supply mode  : Full label print
#G PC6045/0           #G Loop setup        : 1 deviator roll
#G PC6023/0           #G Unwinder motor    : Off
#G PC6024/15500       #G Feed accelerate   : 15500 mm/s2
#G PC6025/15500       #G Feed decelerat.   : 15500 mm/s2
#G PC6029/15500       #G Rew.empty accel.  : 15500 mm/s2
#G PC6030/15500       #G Rew.full accel.   : 15500 mm/s2
#G-----
#G Easyplug Interpreter
#G-----
#G PC1101/5           #G Interface         : Automatic
    
```

```

#PC1102/0          #G Spooler mode      : Mult. print jobs
#PC1103/1          #G *Dispenser ID no. : 1
#PC1104/64        #G Spooler size      : 64 KBytes
#PC2072/0         #G Offline mode      : Interf. disabled
#PC2021/0         #G Interface delay   : 0 ms
#G-----
#G COM1 Port Parameter
#G-----
#PC1201/8         #G Baud rate         : 115200 Baud
#PC1202/8         #G No. of data bits  : 8
#PC1203/2         #G Parity            : None
#PC1204/1         #G Stop bits         : 1 Bit
#PC1205/0         #G Data synch.      : RTS/CTS
#PC1206/0         #G Serial port mode  : RS232
#PC1207/1         #G Frame error       : Display
#G-----
#G Ethernet Parameter
#G-----
#PC1501/0         #G IP Addressassign  : DHCP
#PC1502/144.093.028.109 #G *IP address      : 144.093.028.109
#PC1503/255.255.000.000 #G *Net mask        : 255.255.000.000
#PC1504/000.000.000.000 #G *Gateway address : 000.000.000.000
#PC1505/9100      #G Port address     : 9100
#PC1506/0         #G Ethernet speed    : Auto negotiation
#PC1513/ALS_204_LH_000000#G#G DHCP host name   : ALS_204_LH_000000
#PC1507/1         #G FTP server        : On
#PC1508/novexx#G #G FTP Password    : novexx
#PC1509/1         #G WEB server        : On
#PC1510/5         #G WEB display refr  : 5 s
#PC1511/admin#G #G WEB admin passw. : admin
#PC1512/supervisor#G #G WEB supervisor p.: supervisor
#PC1532/operator#G #G WEB operator p.  : operator
#PC1529/0         #G Time client       : Off
#PC1530/-2105212662 #G Time server IP   : 130.133.001.010
#PC1531/3600      #G Sync. interval   : 3600 s
#PC1533/0.0       #G Time zone         : +0:00
#G-----
#G Signal Interface Parameter Menu
#G-----
#PC6033/0         #G Interface mode    : PLC signals
#G-----
#G PLC Signals Parameter Menu
#G-----
#PC3211/0         #G End dispense mod  : Mode0 inactive
#PC3213/100      #G Disp.end delay    : 100 ms
#PC3214/0         #G End pulse width   : 0 ms
#G-----
#G Applicator Signals Parameter Menu
#G-----
#PC6101/0         #G Applicator type   : LTP - LTPV
#PC6112/0         #G Status outputs    : Off
#PC6102/0         #G Apply mode        : After start sig.
#PC6115/0         #G TouchDown Sensor : Pulse falling
#PC6113/1         #G Lab release time  : 1 ms
#PC6106/1         #G Dwell time        : 1 ms
#PC6107/1         #G Blow on time      : 1 ms
#PC6108/0         #G Restart delay     : 0 ms
#PC6109/2000     #G Position timeout  : 2000 ms
#PC6114/99       #G TouchDownTimeout : Off
#PC6111/0         #G Apply comp. time  : 0 ms
#G-----
#G AI Board Signals Parameter Menu
#G-----
#PC3112/1         #G Status signals    : On
#PC3101/6         #G Applicator type   : Direct Dispense
#PC3102/0         #G Apply mode        : After start sig.
#PC3110/2         #G Start disp. mode  : Pulse rising
#PC3118/0         #G TouchDown Sensor : Pulse falling
#PC3116/1         #G Lab release time  : 1 ms
#PC3106/1         #G Dwell time        : 1 ms
#PC3107/1         #G Blow on time      : 1 ms
#PC3108/0         #G Restart delay     : 0 ms
#PC3115/80       #G Stop lag time     : 80 ms
#PC3109/2000     #G Position timeout  : 2000 ms
#PC3117/99       #G TouchDownTimeout : Off
#PC3111/0         #G Apply comp. time  : 0 ms
#G-----
#G Active signal inputs
#G-----
#PC3230/0         #G Start signal      : Default input
#PC3231/0         #G Inhibit signal    : Default input
#PC3232/0         #G OD sensor signal  : Default input
#G-----
#G Printer Service Menu
#G-----
#PC5111/0         #G Spec parameter 1 : 0

```

```

#PC5112/0          #G Spec parameter 2 : 0
#PC5133/0          #G *Loop dancer val. : 0
#G-----
#G DHCP Addresses
#G-----
#G readonly ID=30001 #G IP address      : 144.093.029.047
#G readonly ID=30002 #G Net mask       : 255.255.254.000
#G readonly ID=30003 #G Gateway address : 144.093.028.001
#G-----
#G Module Firmware Versions
#G-----
#G readonly ID=30004 #G System version  : V2.52
#G readonly ID=30067 #G System revision : 8512
#G readonly ID=30070 #G System date     : Aug  8 2014
#G readonly ID=30076 #G Model-ID       : ALS 256 LH
#G readonly ID=30081 #G storage medias  : RAM,USB
#G readonly ID=30058 #G Applicator int. : V 1 - T 41
#G-----
#G Operational Data
#G-----
#G readonly ID=30014 #G Serv. operations : 0
#G readonly ID=30021 #G Tot. mat. length : 0 m
#G readonly ID=30027 #G Dispensing cycl. : 8
#G readonly ID=30028 #G Operation time   : 0 hours  3 min
#G readonly ID=30082 #G Total Operation  : 2 hours 53 min
#G-----
#G Power supply data
#G-----
#G readonly ID=30029 #G Type           : ALPS600
#G readonly ID=30030 #G Version        : H8.02 F2.03
#G readonly ID=30031 #G Serial number   : 14184007
#G readonly ID=30072 #G PS Temperature  : 35 °C
#G readonly ID=30032 #G Standby+On time : 5 hours 51 min
#G readonly ID=30033 #G On time         : 5 hours 32 min
#G readonly ID=30200 #G PS Reg.        0x000 : 10 00 00 23 B4 00 EF 00 00 00 00 00 00 37 00 29
#G readonly ID=30201 #G PS Reg.        0x010 : 00 00 05 32 00 00 05 51 00 00 06 19 00 00 80 CA
#G readonly ID=30202 #G PS Reg.        0x020 : 2F 00 00 00 00 02 00 00 00 00 00 00 00 00 00
#G readonly ID=30203 #G PS Reg.        0x030 : AB 00 42 40 23 00 60 00 00 00 05 48 00 00 05 45
#G readonly ID=30204 #G PS Reg.        0x040 : 10 00 00 08 02 14 18 40 07 00 01 00 41 00 00 00
#G readonly ID=30205 #G PS Reg.        0x050 : 00 4B 50 25 32 03 00 00 00 00 FF 37 00 00 00 00
#G readonly ID=30206 #G PS Reg.        0x060 : 0A 0A 1E 3C 00 0A 0A 14 0A 00 19 19 00 00 32 1F
#G readonly ID=30207 #G PS Reg.        0x070 : 00 00 05 29 00 00 05 48 00 00 05 26 00 00 05 45
#G readonly ID=30208 #G PS Reg.        0x080 : 41 4C 50 53 36 30 30 20 20 20 20 20 20 20 20 20
#G readonly ID=30209 #G PS Reg.        0x090 : 02 03 00 00 00 00 00 00 00 00 5A 2D 3C 03 00 00 00
#G readonly ID=30210 #G PS Reg.        0x0A0 : 00 00 00 00 00 00 00 00 00 00 00 00 00 00 00 00
#G readonly ID=30211 #G PS Reg.        0x0B0 : 00 00 00 00 00 00 00 00 00 00 00 00 00 00 00 00
#G readonly ID=30212 #G PS Reg.        0x0C0 : 10 00 00 00 00 00 00 00 00 00 00 00 00 00 00 00
#G readonly ID=30213 #G PS Reg.        0x0D0 : 00 4B 50 25 32 03 00 00 00 00 FF 37 00 00 00 00
#G readonly ID=30214 #G PS Reg.        0x0E0 : 0A 0A 1E 3C 00 0A 0A 14 0A 00 19 19 00 00 32 00
#G readonly ID=30215 #G PS Reg.        0x0F0 : 00 00 00 00 00 00 00 00 00 00 00 00 00 00 00 00
#G readonly ID=30216 #G PS Reg.        0x100 : 00 00 00 00 00 00 00 00 00 00 00 00 00 00 00 00
#G readonly ID=30217 #G PS Reg.        0x110 : 00 00 00 00 00 00 08 00 00 16 00 00 31 00 00 A1
#G readonly ID=30218 #G PS Reg.        0x120 : 00 00 57 00 00 18 00 00 00 00 00 00 00 00 00 00
#G readonly ID=30219 #G PS Reg.        0x130 : 00 00 00 00 00 00 00 00 00 00 00 00 00 00 00 00
#G readonly ID=30220 #G PS Reg.        0x140 : 2F 00 00 00 00 00 00 00 00 00 00 00 00 00 00 00
#G readonly ID=30221 #G PS Reg.        0x150 : 00 00 00 00 00 00 00 00 00 00 00 00 00 00 00 00
#G readonly ID=30222 #G PS Reg.        0x160 : 00 00 00 00 00 00 00 00 00 00 00 00 00 00 00 00
#G readonly ID=30223 #G PS Reg.        0x170 : 00 00 00 00 00 00 00 00 00 00 00 00 00 00 00 00
#G-----
#G CPU board data
#G-----
#G readonly ID=30034 #G CPU identifier  : ARM926T Rev5
#G readonly ID=30036 #G PCB Revision    : REV01
#G readonly ID=30037 #G FPGA version    : 3825
#G readonly ID=30039 #G MAC Address     : 000A.44.08.00.05
#G readonly ID=30040 #G Serial number   : A103782011227001
#G readonly ID=30041 #G Production date : 11.09.2012
#G readonly ID=30042 #G PCB part number : A10378
#G readonly ID=30043 #G Board part numb. : 2-01 Kurz
#G readonly ID=30044 #G Manufacturer    : Dummy Record
#G readonly ID=30045 #G Work place      : FCT BlueFin2
#G readonly ID=30046 #G Company name    : Dummy Record
#G-----
#G Display board data
#G-----
#G readonly ID=30059 #G Display Version : V3.10
#G readonly ID=30068 #G Display serialNr : A662603S06091493
#G-----
#G Internal Memory Configuration
#G-----
#G readonly ID=30007 #G RAM memory size : 128 MB
#G readonly ID=30008 #G Flash mem size  : 8 MB STM
#G readonly ID=30013 #G Custom defaults : No
#G-----
#G Printer Debug Menu
#G-----

```

```

#PC5127/0          #G Debug interface : Off
#PC5124/0          #G Debug mask      : 0
#PC5128/-1872945986 #G Debug IP address : 144.093.028.190
#PC5404/0          #G Fields          : Off
#PC5400/0          #G Label generation : Off
#PC5401/0          #G Print handling   : Off
#PC5402/0          #G Variables        : Off
#PC5408/0          #G OLV data         : Off
#PC5403/0          #G Pctrl communica. : Off
#PC5406/0          #G RFID-Reader      : Off
#PC5407/0          #G RFID-Task        : Off
#G-----
#G Product profiles
#G-----
#PB01N/Product 1/
2067=0,6000=10.0,6001=10.0,6002=100.0,6003=19.0,6004=15.0,6034=0.0,
6017=0.0,6035=0,6036=100.0,6037=100.0,6007=1,6041=0,6015=0,2002=0,2069=1,
2006=0,2058=0,2071=0,2068=5,2043=0,6005=0,6006=0,6008=500,6009=64.0,
6040=1,6046=1.64,6018=0,6047=0,6020=3,6038=0,6019=500.0,2015=4,6011=1,
6012=1,6013=0,6014=0,6042=0,6043=0,2020=1,2051=1,2053=0,2075=60,2074=80,
2076=202,6022=0,6028=0,6044=0,6045=0,6023=0,6024=15500,6025=15500,
6029=15500,6030=15500,1101=5,1102=0,1104=64,2072=0,2021=0,1201=8,1202=8,
1203=2,1204=1,1205=0,1206=0,1207=1,1501=0,1505=9100,1506=0,
1513=ALS_204_LH_000000,1507=1,1508=novexx,1509=1,1510=5,1511=admin,
1512=supervisor,1532=operator,1529=0,1530=-2105212662,1531=3600,1533=0.0,
6033=0,3211=0,3213=100,3214=0,6101=0,6112=0,6102=0,6115=0,6113=1,6106=1,
6107=1,6108=0,6109=2000,6114=99,6111=0,3112=1,3101=6,3102=0,3110=2,3118=0,
3116=1,3106=1,3107=1,3108=0,3115=80,3109=2000,3117=99,3111=0,3230=0,
3231=0,3232=0,5111=0,5112=0,5124=0,5128=-1872945986,5404=0,5400=0,5401=0,
5402=0,5408=0,5403=0,5406=0,5407=0#G
#PB02N//CLEAR#G
#PB03N//CLEAR#G
#PB04N//CLEAR#G
#PB05N//CLEAR#G
#PB06N//CLEAR#G
#PB07N//CLEAR#G
#PB08N//CLEAR#G
#PB09N//CLEAR#G
#PB10N//CLEAR#G
#PB11N//CLEAR#G
#PB12N//CLEAR#G
#PB13N//CLEAR#G
#PB14N//CLEAR#G
#PB15N//CLEAR#G
#PB16//CLEAR#G
#G-----
#G Execute system restart ( 134 parameters )
#G-----
#PC999999/-1#G
    
```

Electronics Description

SIGNAL INTERFACE

General notes

The signal interface is in series a D-Sub15 (fem.) connector [?A]. The machine can additionally (optionally) be equipped with separate M12 sockets for inputs and outputs [91][92].

The signal interface can be used as interface for applicator signals or for PLC signals. The selection of the interface type is done via the function menu:

- PLC signals: SIGNAL INTERFACE > Interface mode = „PLC signals“.
- Applicator signals: SIGNAL INTERFACE > Interface mode = „Applic. signals“.



Recommended connector:

- Novexx article no.: A8144 (male), A8145 (fem.)
- *Manufacturer:* Franz Binder GmbH
- *Order no.:* 713 1 99 1487 812 08

See www.binder-connector.de

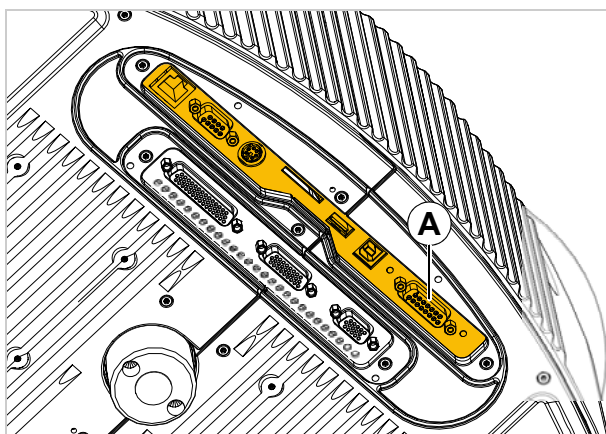

[90] Position of the signal interface (A) at a RH machine with „Gen. 2“-Electronics.



[91] Position of the M12 sockets.

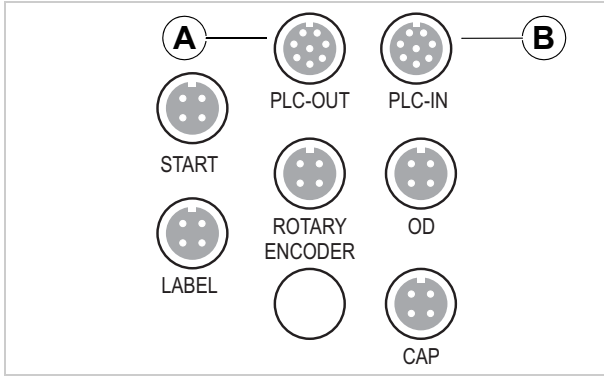

[92] Arrangement of the optional M12 sockets:
A Outputs
B Inputs

Circuit diagrams for signal inputs

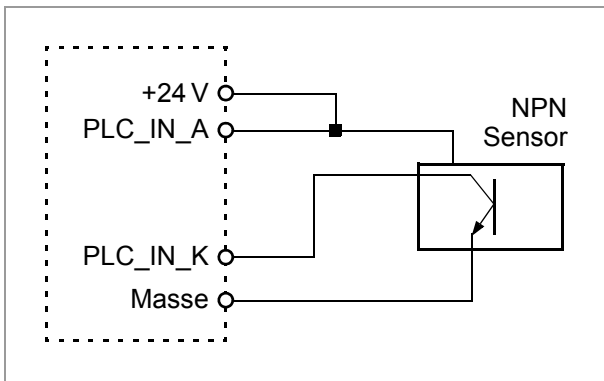

[93] Main circuit for signal inputs (NPN)

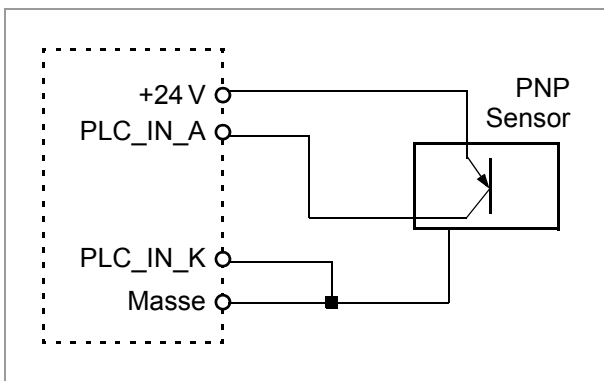

[94] Main circuit for signal inputs (PNP)

Circuit diagram for signal outputs

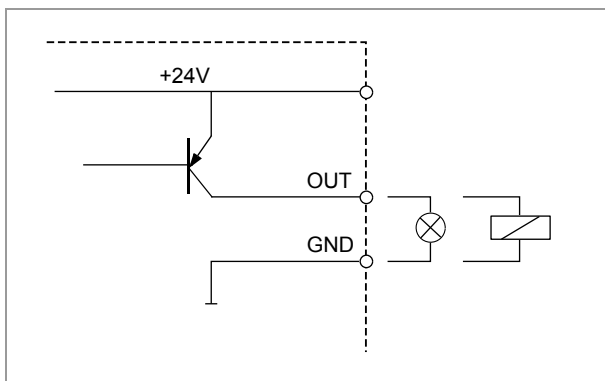

[95] Main circuit for signal outputs.

Signals for applicator connection

Required setting: SIGNAL INTERFACE > Interface mode = „Applicator int.“.

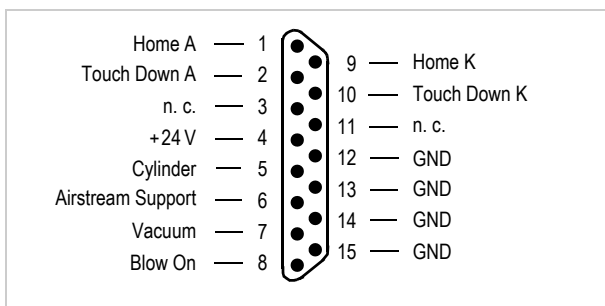

[96] Pin assignment D-Sub15 connector

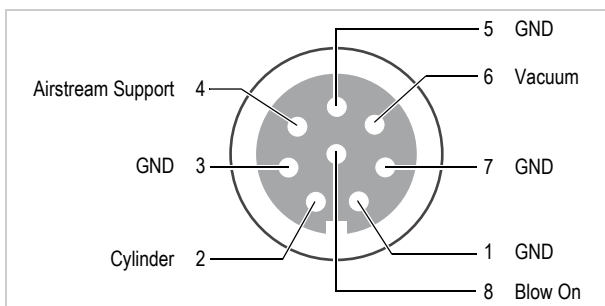

[97] Output signals: Pin assignment M12 socket (female, matching connector: article no. A8144).

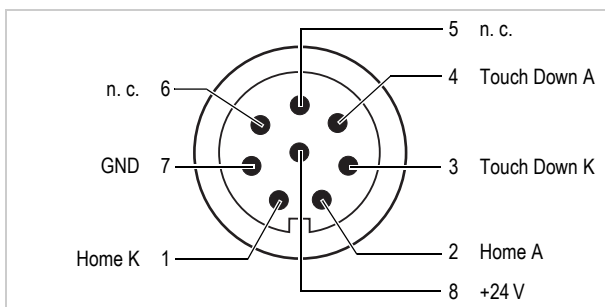

[98] Input signals: Pin assignment M12 socket (male socket, matching connector: article no. A8145).

Signal name	Function
<i>Home</i>	Input Active, if the applicator has reached the home position (application is finished)
<i>Touch Down</i>	Input Use with sensor-controlled applicators (e. g. LTP) Active, if the applicator touches the product
<i>Cylinder</i>	Output Controls the pneumatic cylinder of the applicator Active during the dwell time or until touch down Duration setable with: SIGNAL INTERFACE >APPLIC. SIGNALS > Dwell time
<i>Airstream Support</i>	Output Controls the airstream, which presses the label against the applicator plate. Active after the start signal until start of application (cylinder)
<i>Vacuum</i>	Output Controls the vacuum at the applicator plate Active after the start signal until end of application (cylinder)
<i>Blow On</i>	Output Controls the blow-on valve of the applicator Active after end of application (cylinder) Duration setable with: SIGNAL INTERFACE >APPLIC. SIGNALS > Blow on time



Not every applicator uses the same signals: See chapter [Applicator type <--> Signals](#) on page 100

Applicator type <--> Signals

The table below lists all the signals that are required by the relevant applicator type to be able to work. With some applicator type settings, the interface provides additional signals, which are not mandatory for the applicator to work, e. g. the blow on signal with the setting Applicator type = „LTP - LTPV“

Signal	Applicator												
	LTP(V)	PEP IV	PEP Blow on	PEP II Sens.	ASA	Rev. PEP	Direct Dispense	BTS	O-Ring appl.	LA-BO	LA-TO timed.	LA-TO sensor	
Inputs:	Home Position	X	X	X	X		X		X	X		X	X
	Touch Down	X			X				X				X
Out-puts:	Airstream Support	X	X	X	X	X	X	X ²	X	X	X	X	X
	Vacuum	X ¹		X	X	X	X		X		X	X	X
	Cylinder	X	X	X	X		X		X	X		X	X
	Blow On			X	X	X	X		X	X			
	+24V	X	X	X	X		X		X	X	X	X	X
	BTS ³								X				

[Tab. 16] Signals which are used by the different applicator types (X = signal applied)

- 1) Only used with LTPV
- 2) Only used with pneumatic dispensing edge
- 3) Signal only at optional Applicator Interface



For details about applicator types read the description of function SIGNAL INTERFACE >APPLIC. SIGNALS > Applicator type on page 82.

Signal wave forms of applicator signals



For details about applicator types read the description of function SIGNAL INTERFACE
>APPLIC. SIGNALS > Applicator type on page 82.

PEP

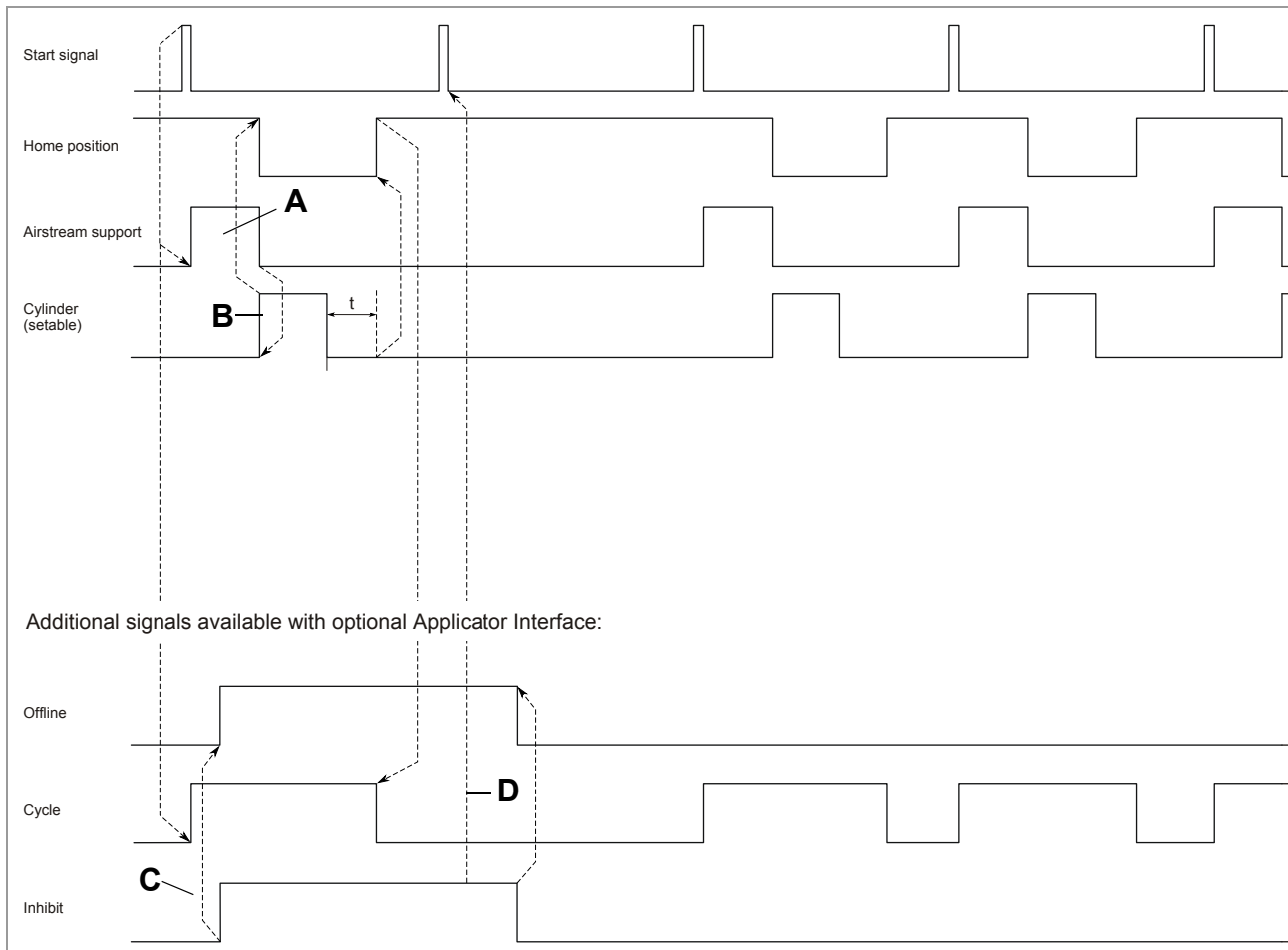

[99] Pattern of control signals over time for the setting Applicator type = „PEP“.

A Duration is determined by label length and dispensing speed. „Airstream Support“ switching to low means the label is dispensed.

B Can be adjusted via “Dwell time”. Duration t is determined by the backwards movement of the applicator. The application cycle ends when the home position signal is high again.

C The output signal „Offline“ follows the input signal „Inhibit“.

D The start signal is ignored because of the active „Inhibit“.

PEP Blow On, LA-TO BO timed

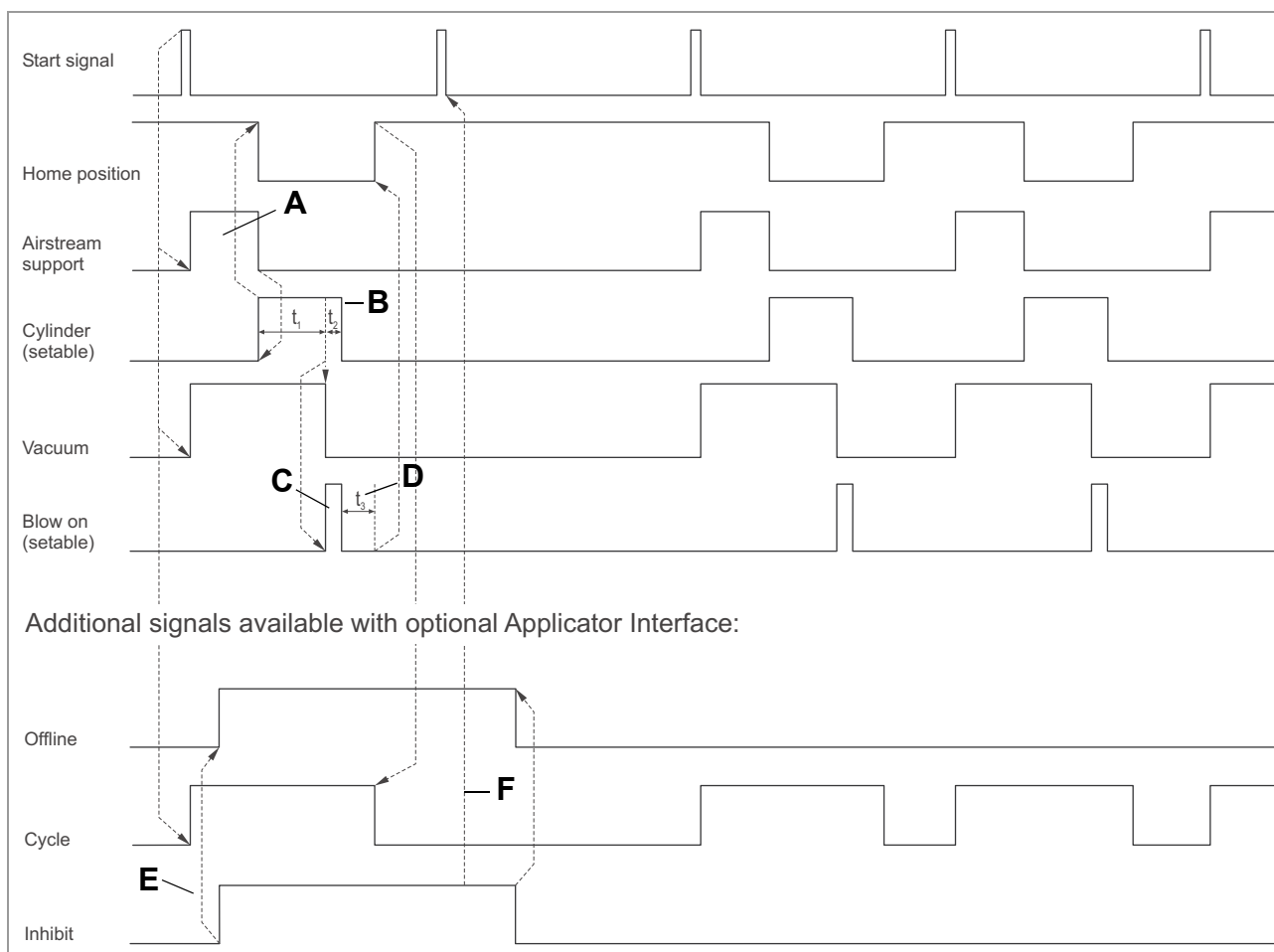

[100] Pattern of control signals over time for the settings Applicator type = „PEP Blow on“ or „LA-TO BO zeitge.“.

- A** Duration is determined by label length and dispensing speed. „Airstream Support“ switching to low means the label is dispensed.
- B** The total duration of Cylinder is the sum of both durations t_1 and t_2 . The duration t_1 is setable by „Dwell time“; t_2 is setable by „Blow on time“ (see note C).
- C** Can be adjusted with „Blow on time“.
- D** Duration t_3 is determined by the backwards movement of the applicator. The application cycle ends when the home position signal is high again.
- E** The output signal „Offline“ follows the input signal „Inhibit“.
- F** The start signal is ignored because of the active „Inhibit“.

Reverse PEP

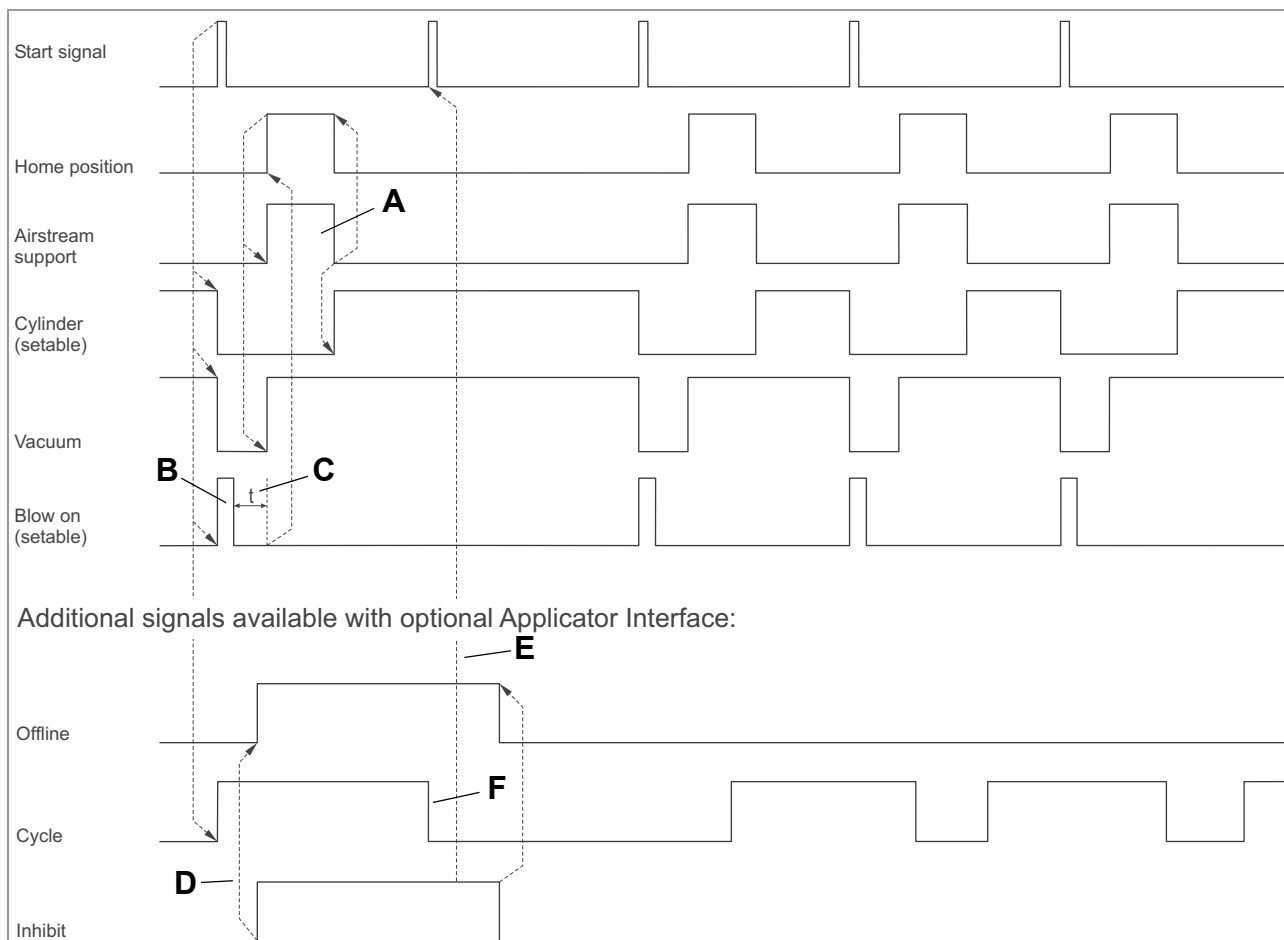

[101] Pattern of control signals over time for the setting *Applicator type = „Reverse PEP“*.

- A** Duration is determined by label length and dispensing speed. „Airstream Support“ switching to low means the label is dispensed.
- B** Adjustable with “Blow on time”.
- C** Duration *t* is determined by the backwards movement of the applicator. The application cycle ends when the home position signal is high again
- D** The output signal „Offline“ follows the input signal „Inhibit“.
- E** The start signal is ignored because of the active „Inhibit“.
- F** The end of „Cycle“ can be adjusted with “Dwell time” (usually, this function sets the end of the „Cylinder“ signal, in case of the Reverse PEP, „Cylinder“ stays active up to the next start signal, what means that the dwell time is ignored).

PEP II Sensor

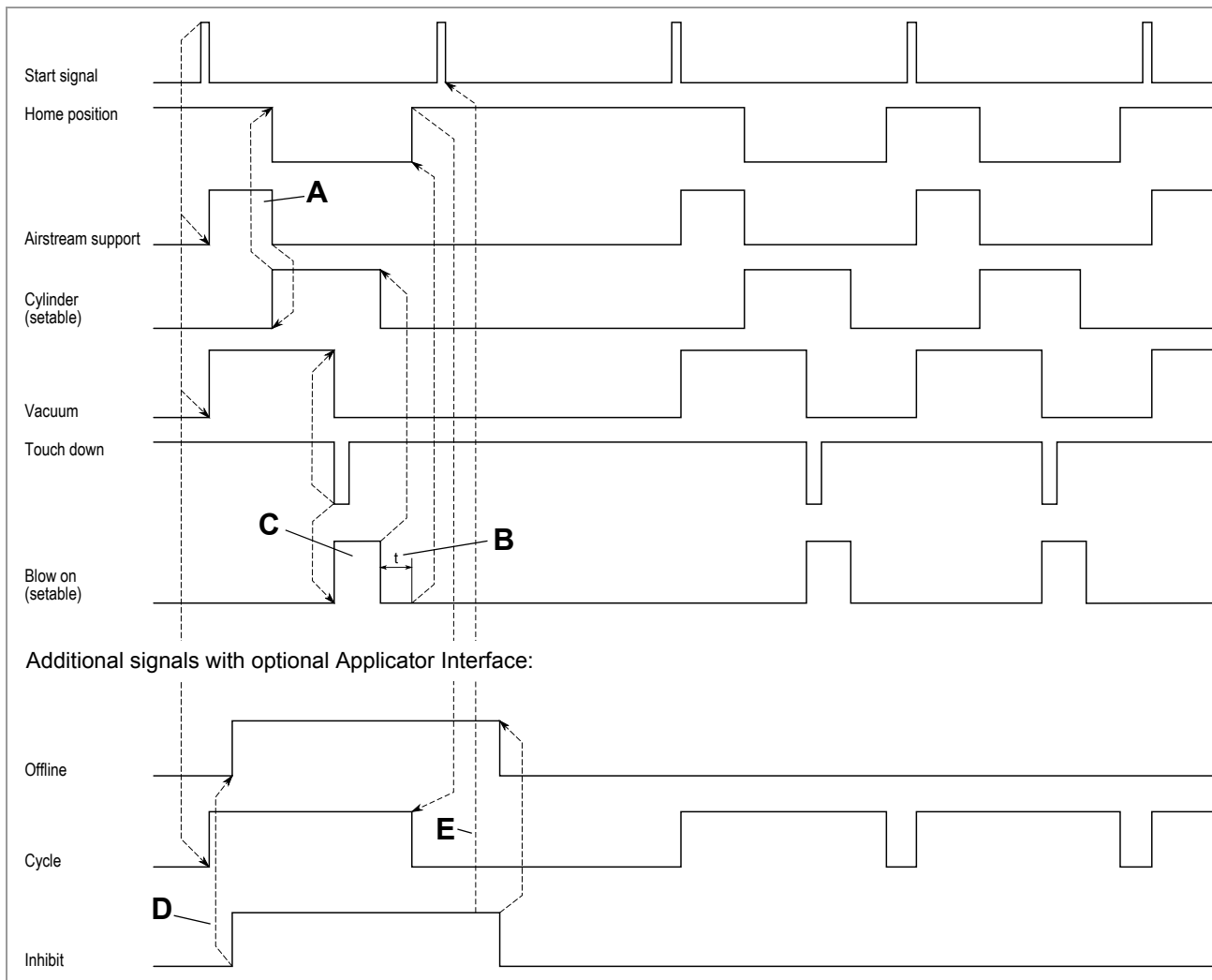

[103] Pattern of control signals over time for the settings Applicator type = „PEP II Sensor“.

- A** Duration is determined by label length and dispensing speed. „Airstream Support“ switching to low means the label is dispensed.
- B** Duration t is determined by the backwards movement of the applicator. The application cycle ends when the home position signal is high again.
- C** Adjustable with “Blow on time”.
- D** The output signal „Offline“ follows the input signal „Inhibit“.
- E** The start signal is ignored because of the active „Inhibit“.

LA-TO sensor

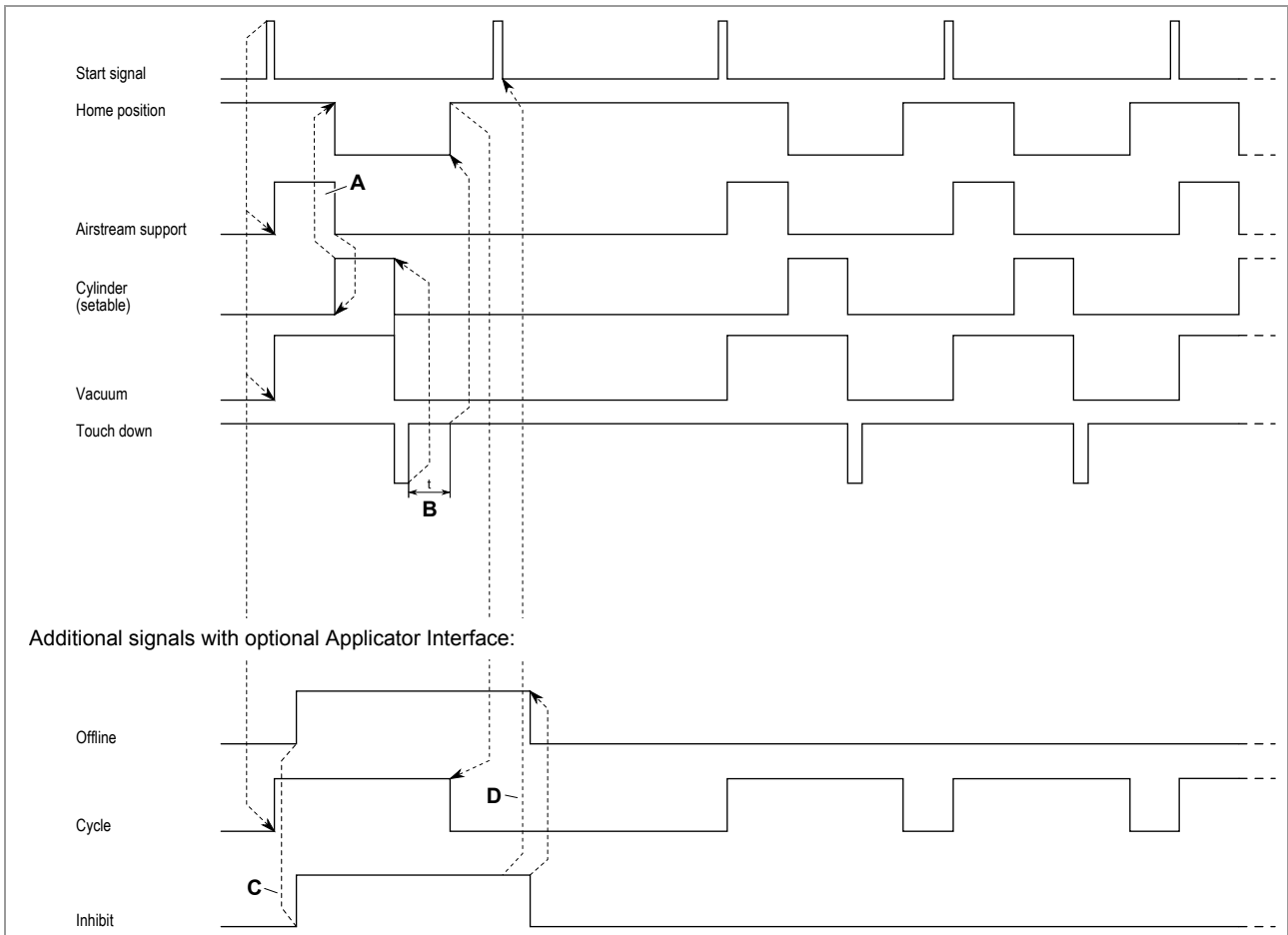

- [104] Pattern of control signals over time for the setting Applicator type = „LA-TO Sensor“.
- A** Duration is determined by label length and dispensing speed. „Airstream Support“ switching to low means the label is dispensed.
 - B** Duration t is determined by the backwards movement of the applicator. The application cycle ends when the home position signal is high again.
 - C** The output signal „Offline“ follows the input signal „Inhibit“.
 - D** The start signal is ignored because of the active „Inhibit“.

LA-TO timed

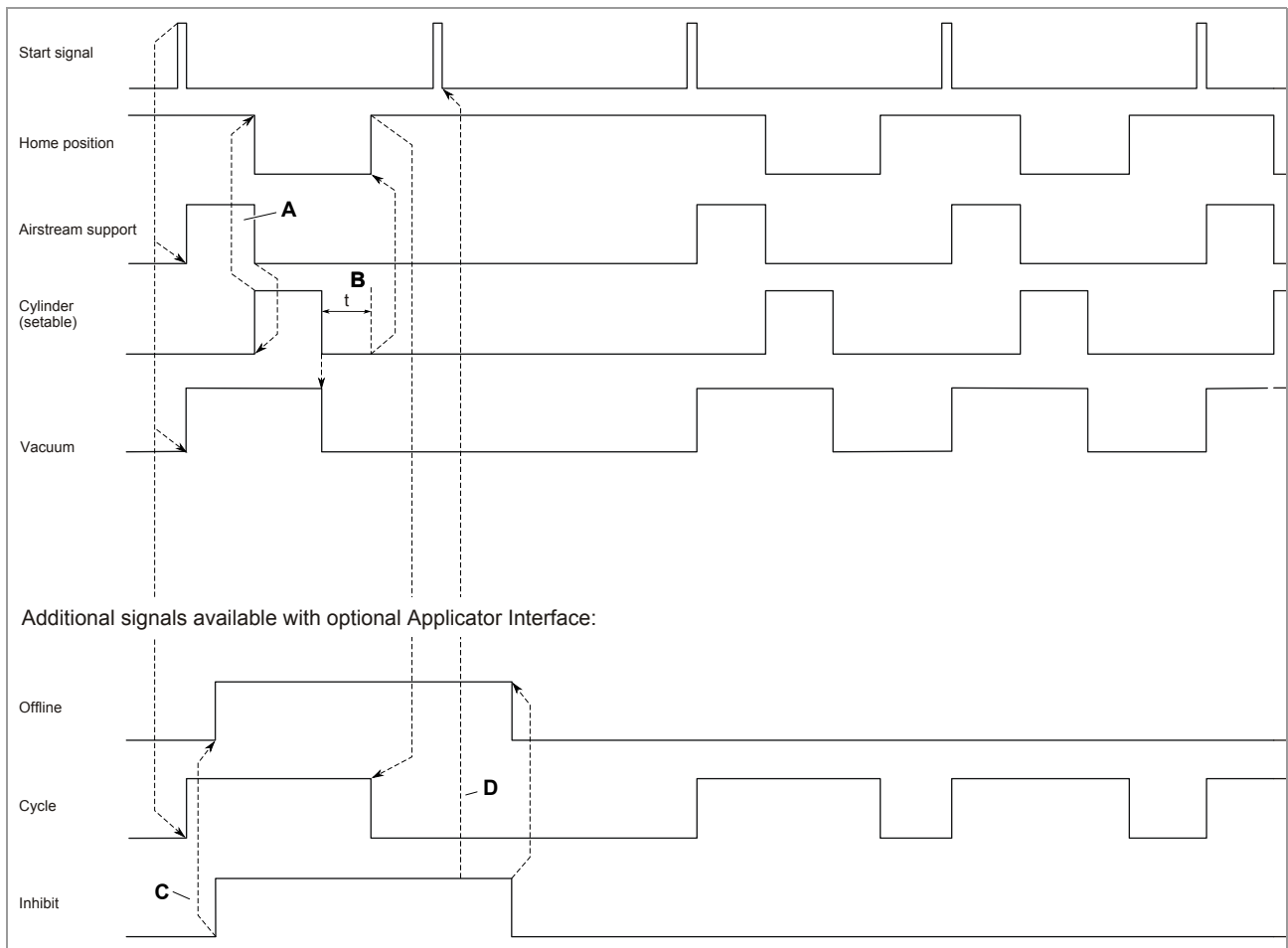

- [105] Pattern of control signals over time for the setting *Applicator type = „LA-TO zeitgest.“*.
- A** Duration is determined by label length and dispensing speed. „Airstream Support“ switching to low means the label is dispensed.
 - B** Duration *t* is determined by the backwards movement of the applicator. The application cycle ends when the home position signal is high again.
 - C** The output signal „Offline“ follows the input signal „Inhibit“.
 - D** The start signal is ignored because of the active „Inhibit“.

ASA

The ASA is a special case, which does not have any moving parts. The label is applied only by compressed air. Therefore, signals controlling the movement of the applicator (Home position, Cylinder) are not required.

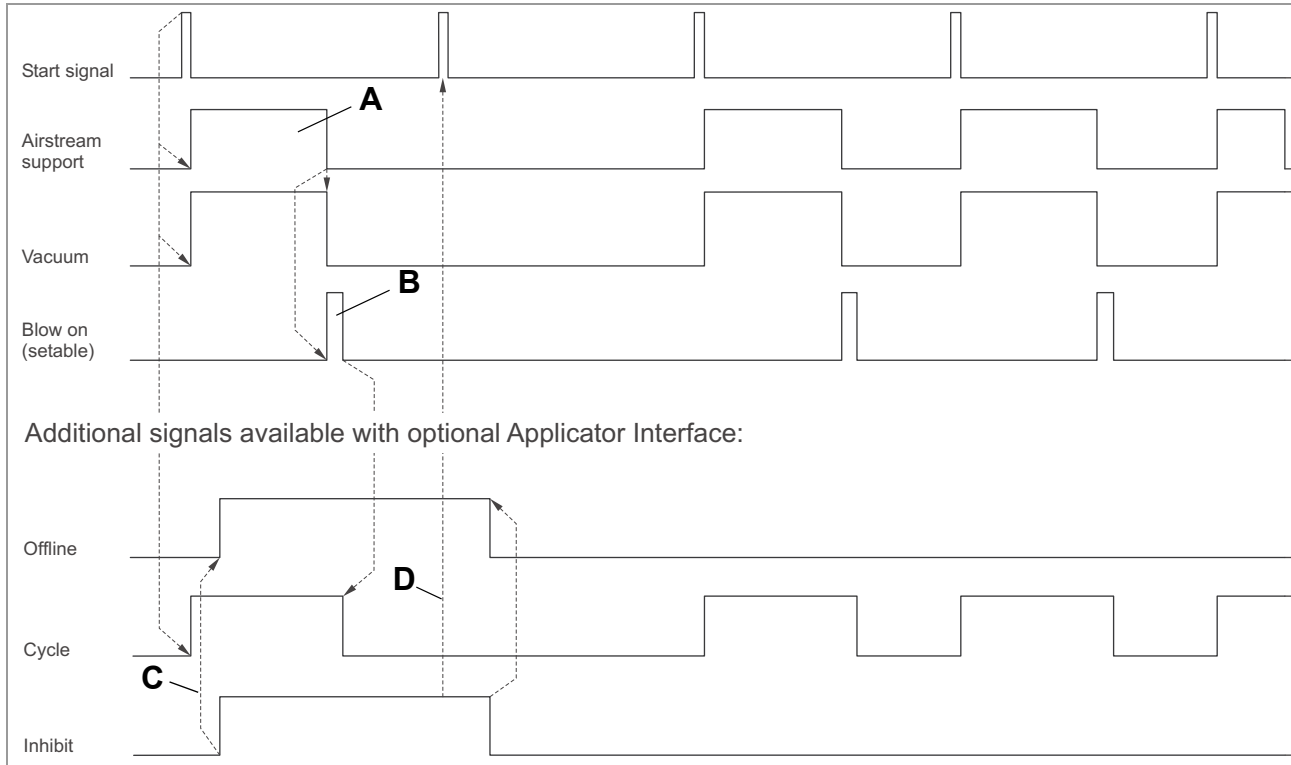

[106] Pattern of control signals over time for the setting Applicator type = „ASA“.

A Duration is determined by the label length and dispensing speed. „Airstream Support“ switching to low means the label is dispensed.

B Can be adjusted via “Blow on time”.

C The output signal „Offline“ follows the input signal „Inhibit“.

D The start signal is ignored because of the active „Inhibit“.

LA-BO

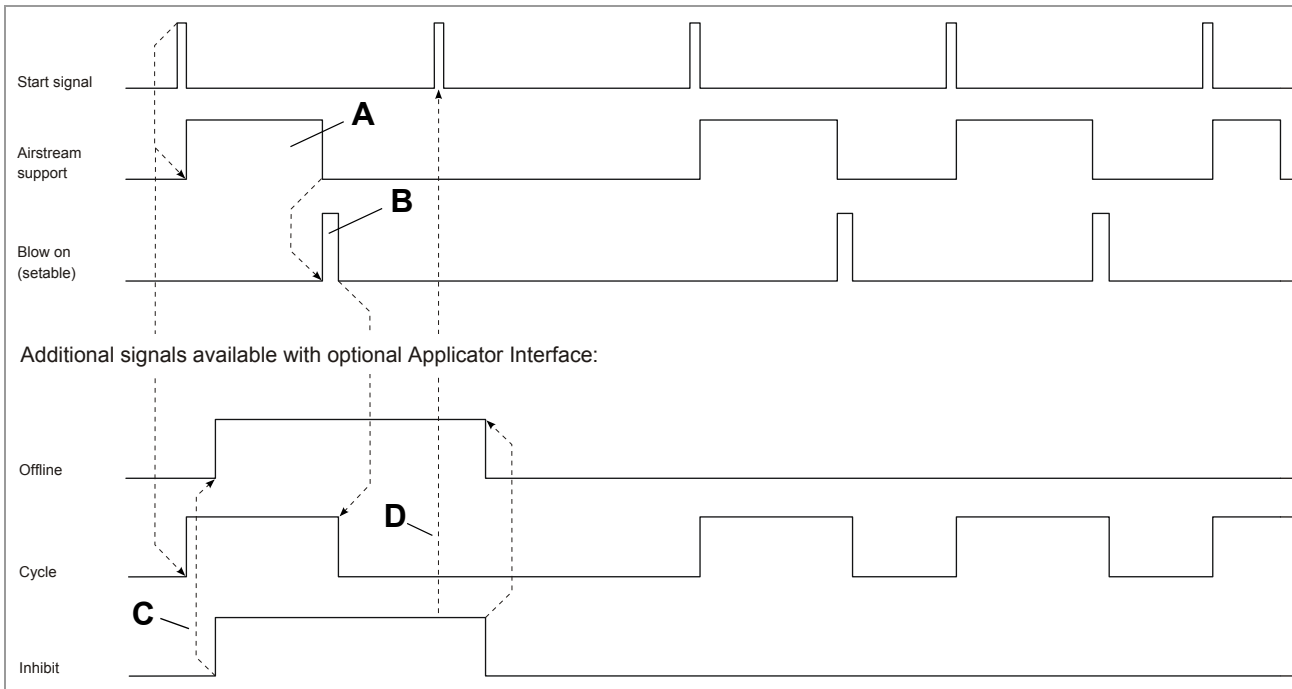

[107] Pattern of control signals over time for the setting Applicator type = „LA-BO“.

- A** Duration is determined by the label length and dispensing speed. „Airstream Support“ switching to low means the label is dispensed.
- B** Can be adjusted via “Blow on time”.
- C** The output signal „Offline“ follows the input signal „Inhibit“.
- D** The start signal is ignored because of the active „Inhibit“.

Signals for PLC connection

Required setting: SIGNAL INTERFACE > Interface mode = „PLC signals“.

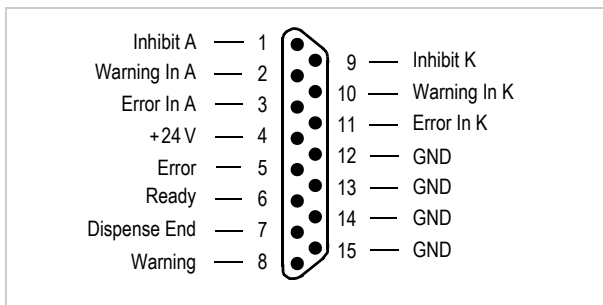

[108] Pin assignment D-Sub15 connector

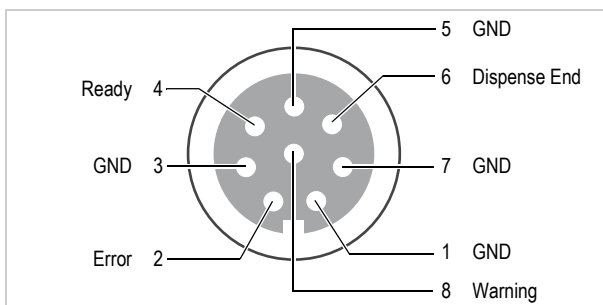

[109] Pin assignment M12 socket (fem. connector; output signals). Matching connector: article no. A8144.

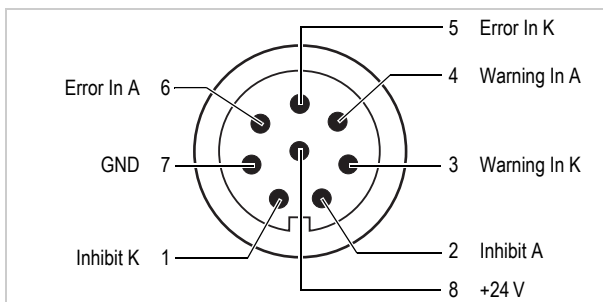

[110] Pin assignment M12 socket (male connector; input signals). Matching connector: article no. A8145.

Signal name	Function
<i>Inhibit</i>	<p>Input</p> <p>If the signal is active, start signals at both signal interfaces (standard and AI) are ignored. Triggering via -button is possible.</p> <p>AI installed: alternatively, the Inhibit input at the AI can be activated (SIGNAL INTERFACE > ACTIVE INPUTS > Inhibit signal = „Opt. appl.interf“)</p> <p>$I_{in} \geq 7 \text{ mA}$</p>
<i>Warning In</i>	<p>Input</p> <p>An external warning status can be signaled by OR-link at the warning output</p> <p>$I_{in} \geq 7 \text{ mA}$</p>
<i>Error In</i>	<p>Input</p> <p>An external error status can be signaled by OR-link at the error output</p> <p>$I_{in} \geq 7 \text{ mA}$</p>

Signal name	Function
<i>Ready</i>	Output Active in dispensing mode (online or online settings) Not active in configuration mode (offline inclusive error status) and in tandem mode at the deactivated machine $I_{out} < 500 \text{ mA}^1)$
<i>Error</i>	Output Signal active when an error message appears on the operator panel display $I_{out} < 500 \text{ mA}^1)$
<i>Dispense End</i>	Output Signal that can be used to activate a secondary unit (e.g. a printing unit). Signal length and delay can be set via the function menu $I_{out} < 500 \text{ mA}^1)$
<i>Warning</i>	Output Active, if a warning status occurs (e. g. label roll diameter below desired nominal value) $I_{out} < 500 \text{ mA}^1)$

1) I_{max} over all outputs < 1500 mA

Signal response „Dispense End“

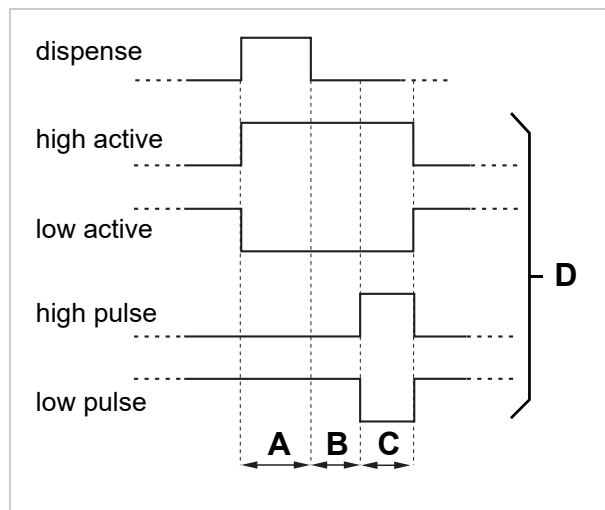

[111] Signal response of „Dispense End“.

The signal „Dispense End“ can be controlled by the functions in the SIGNAL INTERFACE > PLC SIGNALS submenu.

A Duration of the dispensing operation [111A]

B Period setable via SIGNAL INTERFACE > PLC SIGNALS > Disp.end delay [111B]

C Period setable via SIGNAL INTERFACE > PLC SIGNALS > End pulse width [111C]

D Signal modes; setable via SIGNAL INTERFACE > PLC SIGNALS > End dispense mod [111D]

- Modes *high/low active*: The signal is activated with the start of dispensing. The duration is the sum of the three periods A+B+C.

- Modes *high/low pulse*: The signal is activated after dispensing ended and after period B and it lasts period C [111C].

Impact of the inhibit signal

The description in this chapter only affects the inhibit input at the standard signal interface (in PLC mode), *not* the inhibit input at the optional applicator interface.

The impact of the inhibit signal on the start signal is influenced by MACHINE SETUP > On inhibit enter and MACHINE SETUP > On inhibit leave. Combining the settings of the two functions has different effects.

To simplify the description in the following, abbreviations are used for the settings (see table). „A“ refers to the rising slope, „B“ refers to the dropping slope of the inhibit signal.

Function	Setting	Abbrev.	Signal slope	Effect
MACHINE SETUP > On inhibit enter	„Do saved starts“	A1	Low-high	Queue is processed
	„Del saved starts“	A2		Queue is deleted
MACHINE SETUP > On inhibit leave	„Do saved starts“	B1	High-Low	Queue is processed
	„Del saved starts“	B2		Queue is deleted

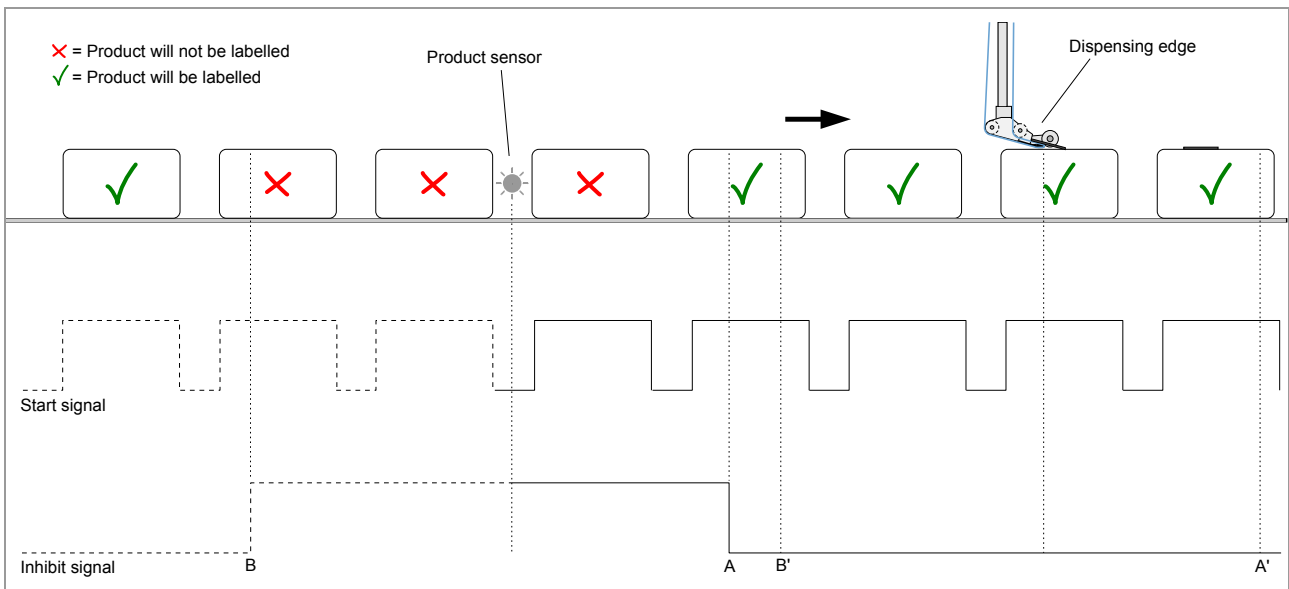

[112] Example for setting combination A1B1 and A1B2.

- A = relative position of the product sensor at the time of *rising* signal slope
- A' = relative position of the dispensing edge at the time of *rising* signal slope
- B = relative position of the product sensor at the time of *dropping* signal slope
- B' = relative position of the dispensing edge at the time of *dropping* signal slope

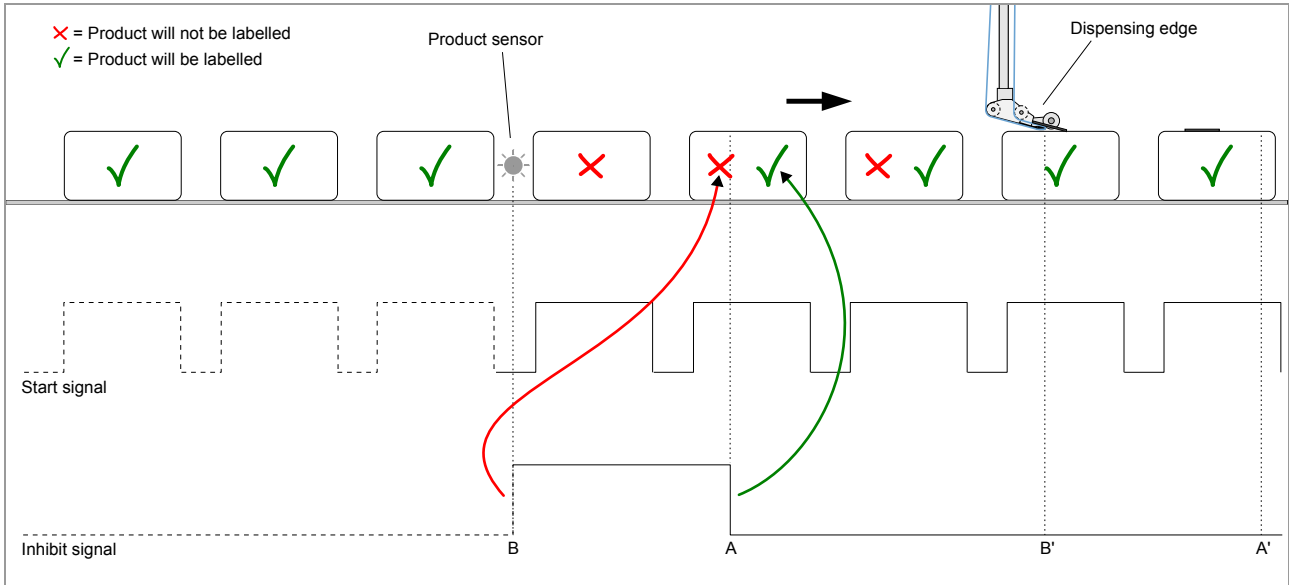

[113] Example of setting combination A1B2. Green arrow: the rising slope causes products registered in the queue to be labelled. Red arrow: the dropping slope causes the queue to be deleted. Two of the products are matching both conditions, in this case, the impact of the dropping slope counts.

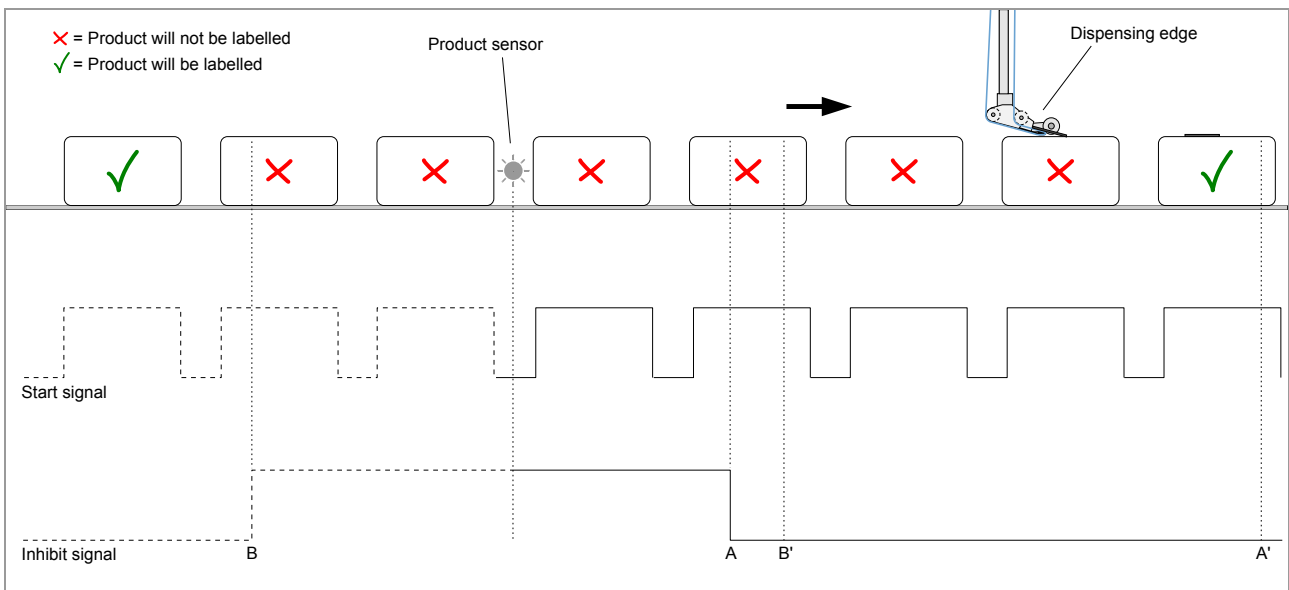

[114] Example of setting combination A2B1.

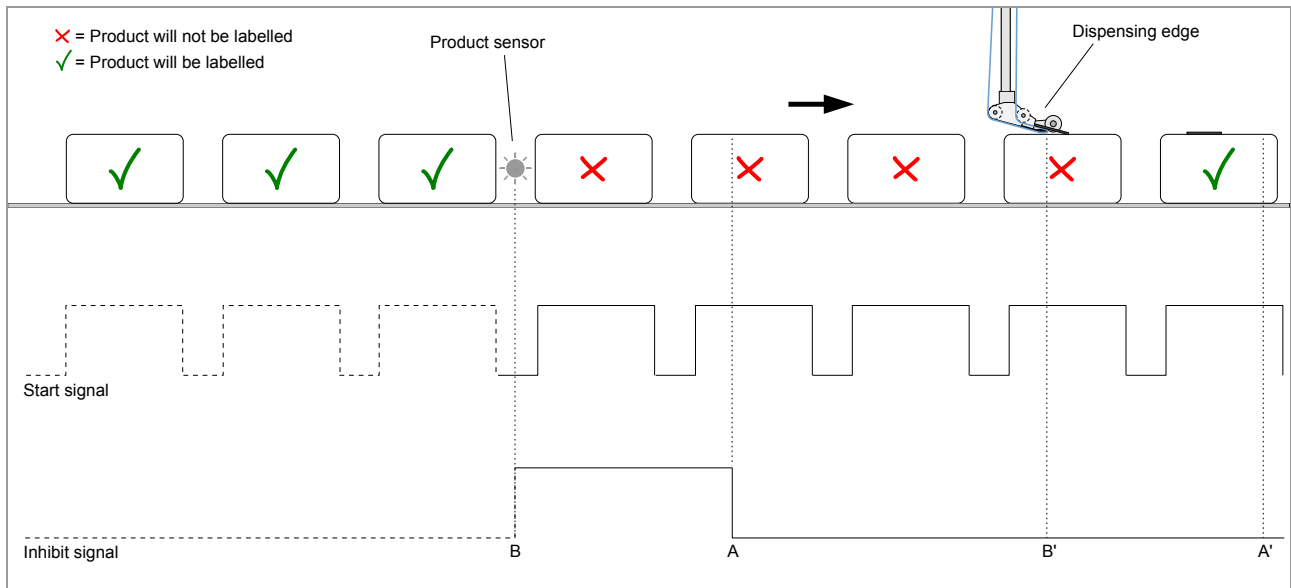

[115] Example of setting combination A2B2.

DATA INTERFACES

Overview connector positions

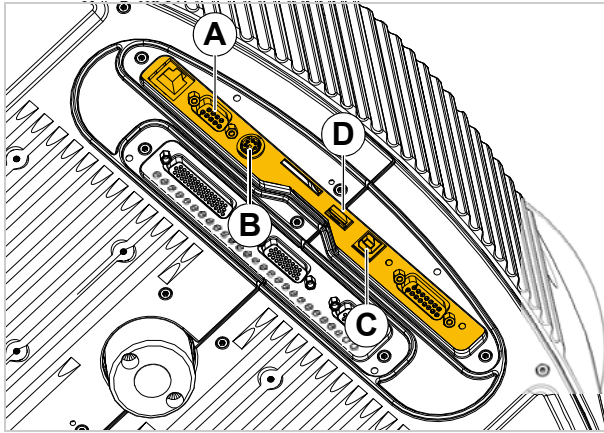

- [17] **A** RS 232 interface (D-Sub9)
B Connection for external operator panel (Mini DIN 6)
C USB interface (device, not supported with „Gen. 2“)
D USB interface (host, only at „Gen. 2“ board)

RS 232

Pin	Signal
1, 4, 6	connected
2	RxD
3	TxD
5	Ground
7	RTS
8	CTS
9	not used

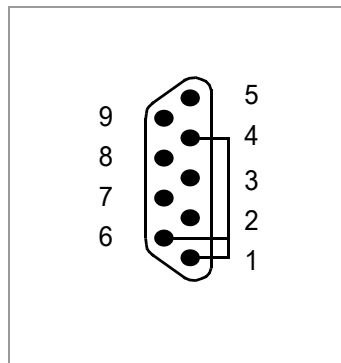

[Tab. 18] Pin assignment for RS 232 interface (looked at from „PC point of view“; Dispenser = DCE)

- i** Suitable connection cable to a PC:
- D-Sub9, 1:1, connector-socket (extension cable)
 - Article number: A1207

Connection for external operator panel

The connector [17B] allows for the connection of an external operator panel.

See chapter [Connecting / mounting the external operator panel](#) on page 71.

USB (device)

Not yet supported with „Gen. 2“ CPU board.

Pin	Signal
1	V _{CC} from the host (detection, if a connection is existing)
2	Data -
3	Data +
4	Ground

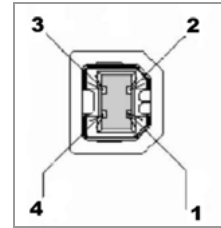

[Tab. 19] Pin assignment for USB interface

- i** Suitable connection cable to a PC:
- USB cable A/B
 - Article number: 126738

USB (host)

Only at „Gen. 2“ CPU board.

Pin	Signal
1	V _{CC}
2	Data-
3	Data+
4	GND

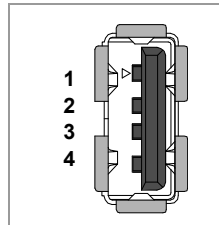

[Tab. 20] Pinout USB interface

Ethernet

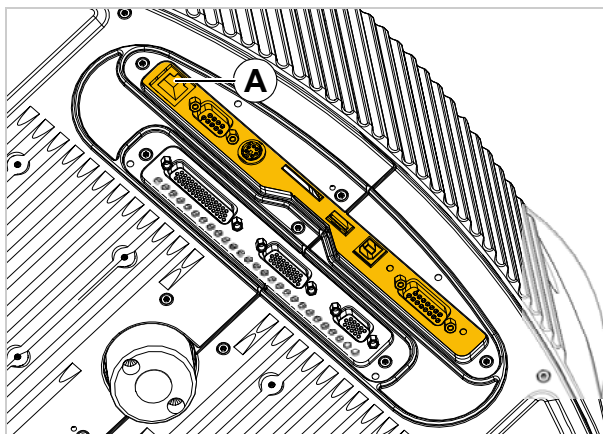

[21] Ethernet interface (A)

Pin		Signal
A	B	
1	1	TD +
2	3	TD -
3	2	RD +
4		Termination
5		Termination
6	4	RD -
7		Termination
8		Termination

[Tab. 22] Pin assignment for Ethernet interface

A Connection at standard device (RJ 45)

B Connection at device with splash/dust guard (M12 D-coded)

Integration of the Ethernet interface

- 10/100 Base T
- The transfer rate is set by auto-negotiation
- LED display on the interface:

LED	Meaning
Green	<i>Continuously lit:</i> High transfer rate (100 Mbit/s)
Yellow	<i>Continuously lit:</i> Labeller is connected with the network <i>Flashing:</i> Communicating with network

i **MAC address:** Every device that is to be used in an Ethernet needs a unique MAC (Media Access Control) address. This consists of 6 Bytes and that are generally separated by colons or hyphens when the address is written out (hexadecimal, e.g. 00:0a:44:02:00:49 or 00-0a-44-02-00-49). The first three bytes are always 00:0A:44 (Novexx identifier); the last 3 bytes vary from device to device. Manufacturers are responsible for assigning MAC addresses to the devices they make.

IP address: The labeller firmware implements a TCP/IP protocol stack, which means that the labeller needs an IP address for the network in addition to its MAC address. IP addresses are always written in decimal format as 4 bytes separated by points (e.g. 192.168.1.99). IP addresses are assigned by whoever runs the network, generally a network administrator.

MAC and IP addresses originate from different protocol layers and are fundamentally independent from each other.

Setting IP parameters

The following alternatives are available for setting the IP parameters:

Fixed setting

The preset values are as follows:

- IP address: 192.168.1.99
- Net mask: 255.255.255.0
- Default Gateway: 0.0.0.0

Assigned by DHCP server

The following are requested from the DHCP server: *Address, net mask, default gateway*. During the request process, a device name is communicated to the DHCP server, to assist the system administrator. This name is made up of the model of labeller + 3 characters from the MAC address.

- Example: ALS_204__020049
- It is not necessary to connect to a name server

This is where to set the IP parameters in the labeller function menu:

Menu	Function	Description
INTEFACE PARA	IP Addressassign	Set to “Fixed IP address” or “DHCP”
>NETWORK PARAM.	IP address	Input fields for the IP parameters, if the method of assigning addresses was set to Fixed IP address”.
	Net mask	
	Gateway address	

IMPORTANT: These addresses must be assigned with care, ensuring they are unique on each machine. Call in your network administrator.

Novexx Solutions GmbH
Ohmstraße 3
85386 Eching
Germany
☎ +49-8165-925-0
www.novexx.com

NOVEXX 
SOLUTIONS