

OPERATING MANUAL

LA-BO Applicator



Contents

Please Note - 3

General Information - 3

Validity of this manual and required compliance - 3

How information is represented - 4

For your safety - 5

Intended use - 5

Information and qualification - 5

Operating safety of the machine - 7

Product description - 8

Application Notes - 8

System requirements - 8

Component overview (XLS 2xx, ALS 306, ALX 73x) - 10

Component overview (XPA 93x) - 12

Technical data - 14

Startup - 17

Mounting & Setting on ALS/XLS 2xx, ALS 306 or ALX 73x - 17

Mounting - 17

Adjustment/Setting - 19

Mounting & setting on XPA 93x - 20

Montage - 20

Adjustment/Setting - 21

Installing the service unit - 22

Connecting compressed air - 23

Adjusting the application height - 24

Adjustments to the label material - 24

Adjusting the sliding bars in the vacuum grid - 24

Adjusting the air nozzles in the vacuum grid - 26

Adjusting the air stream support - 27

Setting the dispensing position parameter - 28

Operation - 29

Activating/deactivating the applicator - 29

Cleaning - 30

Fault correction - 31

Appendix - 32

Pneumatic diagram - 32

EU Declaration of Incorporation - 33

Please Note

GENERAL INFORMATION

Validity of this manual and required compliance

Contents

The following manuals are available for the applicator LA-BO:

Manual	Target group	Medium	Availability
Operating manual	Operating personnel Service personnel	PDF file	NOVEXX Solutions website www.novexx.com
Service manual	Service personnel		NOVEXX Solutions Partner Portal https://partner.novexx.com
Spare parts catalogue			

The present *operating manual* describes the installation and operation of the named applicator. For safe and proper operation of the print- & apply system with attached applicator, it is indispensable to consult the operating manual for the relevant print- & apply system too.

For technical questions not covered in this manual:

- ▶ Follow the instructions of the service manual for the applicator and for the applied print & apply system or
- ▶ Request a service technician from our sales partner.

NOVEXX Solutions customer service department is available especially for configuration settings and malfunctions.

Liability

NOVEXX Solutions reserves the right:

- To make changes in design and components, and to use equivalent other parts than those specified in line with technological progress.
- To change information in this manual.

Any obligation to extend these changes to machines previously delivered is excluded.

Copyright

NOVEXX Solutions retains all rights to this manual and its appendices. Reproduction, reprint or any other type of duplication, including parts of the manual, are permitted only with written approval.

Manufacturer

Novexx Solutions GmbH
 Ohmstrasse 3
 D-85386 Eching, Germany
 Tel.: +49-8165-925-0

www.novexx.com

How information is represented

Explanation of symbols

To enhance readability and make information easier to find, different types of information are identified:

▶ Instruction with no order of tasks assigned

1. Numbered instructions introduced by preceding text
2. The specified order must be followed!

|| Note.

- Enumeration of features
- Other feature

 The Experts symbol identifies activities that are reserved exclusively for qualified and specially trained personnel.

Warning Notes

Warning notes are specially highlighted:



WARNING!

Warning notes with the signal word **WARNING** refer to risks that can result in severe or fatal injuries! The note contains safety measures to protect affected persons.

- ▶ Instructions must be followed without exception.

CAUTION!

Warning notes with the signal word **CAUTION** refer to risks that can result in property damage or personal injury (minor injuries). The note contains instructions for preventing damage.

- ▶ Instructions must be followed without exception.

Illustrations

Illustrations appear in the text where required. References to the illustrations are shown in brackets, if necessary (see table).

Reference to illustration	Application
none	<ul style="list-style-type: none"> • Only one illustration • Reference to the illustration is obvious • No position number in the illustration
(A)	<ul style="list-style-type: none"> • Only one illustration • Reference to the illustration is obvious • Position number in the illustration
(see fig. above)	<ul style="list-style-type: none"> • Several illustrations • No position number in the illustration

Reference to illustration	Application
(see fig. above, pos. A)	<ul style="list-style-type: none"> • Several illustrations • Position number(s) in the illustration

Table 1: Different references to illustrations.

Parameters

Parameters in the parameter menu are represented in the format **Menu name > Parameter name** in grey type.

FOR YOUR SAFETY

Intended use

The LA-BO applicator is a device for automatic attachment of self-adhesive labels, which are supplied to the applicator by one of the following labelers or print & apply systems.

Print & apply systems:

- ALX 73x
- XPA 93x

Labelers:

- ALS/XLS 20x
- ALS/XLS 256
- ALS/XLS 272
- ALS 306

The LA-BO is mounted to the respective machine by means of its base plate. In contrast to direct dispensing from the dispensing edge of the machine onto the product, the LA-BO can bridge distances of up to 10 cm between dispensing edge and product. The applicator is controlled by an optional applicator interface (depending on the machine type) or by the internal applicator interface (ALS only, for details read chapter Systemrequirements > **Machine type** on page 8). The electrical connection to the LA-BO is done via a plug connector. The drive is provided by compressed air.

The application process is triggered by means of a product sensor, which is connected to the machine.

Any other type of or more extensive application will be considered non-intended use. NOVEXX Solutions shall assume no liability for damage resulting from non-intended use of the machine.

Information and qualification

Ensuring the necessary qualification

- Only fully trained and authorised personnel are permitted to operate, adjust and maintain the machine.
- Service work must only be performed by qualified and appropriately trained technical specialists (service technicians) or the customer service department.
- Areas of responsibilities for operating and servicing the machine must be clearly defined and consistently observed.

Qualification for operation

The instruction provided for the operating personnel must ensure:

- That the operating personnel can use the machine independently and without danger.
- That the operating personnel can rectify minor operating faults (for example a paper jam) independently.
- At least 2 persons should be instructed in operation.
- Have a sufficient quantity of label materials available for tests and instruction.

Making note of information

The device can only be operated safely and efficiently by complying with all of the requisite information!

- Carry out the installation, connection, programming, setting, and repairing of the machine exclusively in accordance with the specifications in this manual.
- Before beginning operation, read this operating manual and the user manual of the machine to which the applicator is attached and follow all of the instructions.
- Observe all additional safety and warning information given on the device.
- Only technically knowledgeable persons are permitted to operate the device and make settings on it.

Any product liability and warranty claims will not be valid unless the machine is operated according to the instructions in the operating manual.

Keep product information at hand

This operating manual

- must remain readily available for operating personnel at a location near to the machine.
- The safety and warning symbols and messages on the machine must be kept in a clean and legible state. Replace any signs that are damaged or missing.
- can be downloaded here: <https://www.novexx.com/service-and-support/user-manuals/>



Operating safety of the machine

Intended use

The machine must only be used in accordance with the specifications described in chapter **Technical data** on page 14 and in chapter **Intended use** on page 5.



WARNING!

Improper usage of the machine can lead to accidents, material damage and loss of production!

- ▶ Only use the unit in accordance with the instructions specified in this manual.
- ▶ Only configure the unit in accordance with this manual and with the required care.
- ▶ Only use original accessories.
- ▶ Do not make any modifications or alterations to the unit.
- ▶ Repairs to the device may only be performed by authorised specialists who are aware of the risks involved.

Protection against injuries by electrical current

Applicators of type LA-BO operate using low voltage 24 V DC supplied by NOVEXX Solutions print & apply systems or labelers (“machine”).



WARNING!

The machine to which the applicator is attached works with mains voltage! Contacting electrically live components can cause lethal electrical shocks and burns.

- ▶ Never connect the LA-BO unit directly to mains voltage!
- ▶ Only operate the unit once the housing has been reassembled properly.
- ▶ Before cleaning, switch off the machine and remove the power cable from the socket.
- ▶ Keep the unit dry.
- ▶ If liquids have penetrated the LA-BO unit, switch the machine off and disconnect or unplug its power cable immediately. Inform a service technician.

Protection against injuries by mechanical action



WARNING!

Risk of injury due to moving parts!

Risk of crushing hands between the vacuum grid of the LA-BO and the conveyed products!

- ▶ Never reach between the product and the LA-BO edge while the unit is in operation or ready for operation.

Protection against injuries by chemicals



WARNING!

Operating materials such as cleaning agents or the solvents in glues can be damaging to health.

- ▶ Always follow the instructions, use and safety regulations specified by the manufacturer!

Product description

APPLICATION NOTES

Installation position

Permissible installation positions for the LA-BO are:

- *Vertical*: if application takes place from top to bottom (also referred to as “top labelling” - the product is located below the applicator) or from bottom to top (also referred to as “bottom labelling” - the product is located above the applicator).
- *Horizontal*: the product is located next to the applicator (also referred to as “side labelling”).

Device designation

LA-BO stands for "Label Applicator Blow-On". The abbreviation 'BO' (blow on) distinguishes this applicator from other application techniques such as 'touch on' or 'swing on'.

Mode of Operation

The fan in the LA-BO is continuously powered, creating a strong inwards airflow through the aluminium vacuum grid at the bottom side. While a label is dispensed, the small blow pipe is activated, creating a small focused air stream to force the label against the aluminium grid. When the label is fully dispensed, it is held onto the aluminium grid by the inwards airflow and is then stand-by to blow off the label. When the application cycle is triggered by the product sensor, a high volume air pressure is applied through the air nozzles built-in above the aluminium grid. The nozzles which are not covered by the black sliding bars will now blow off the label towards the product at a high velocity. After that, the next label can be dispensed on the grid.

 [Video of an application.](#)

 [Video of an application.](#)

SYSTEM REQUIREMENTS

Machine type

Machine	Article no. LA-BO	Controller	Notes
XPA 934/935/936 LH	N102171	8IO	Machine must be equipped with short dispensing edge and 8IO board.
XPA 934/935/936 RH	N102333		

Machine	Article no. LA-BO	Controller	Notes
ALS 306 LH	A9776	AI or internal	Machine must be equipped with L-shape fixed dispensing edge (ALX 73x: holder with 160 mm width mandatory; ALS/XLS 272: holder with 110 mm width mandatory). The AI is an Option; nevertheless, the connector at the LA-BO cable matches the AI. As a standard, the internal applicator interface can be used, but limits the use of PLC signals. For use with the standard interface, the adapter cable A9103 (option) is mandatory.
ALS 306 RH	A9777		
ALX 734/735/736 LH	A9776		
ALX 734/735/736 RH	A9777		
ALS/XLS 204/206/256/272 LH (brief: ALS/XLS 2xx)	A8677		
ALS/XLS 204/206/256/272 RH (brief: ALS/XLS 2xx)	A8678		

Table 2: Machines at which the LA-BO can be operated and the appropriate article numbers for ordering.

By ordering the specified part number, you will receive a LA-BO applicator with installation material and connection cables, suitable for installation on the device type listed at the beginning of the line. The Applicator Interface (AI) board is *not* part of the delivery and has to be ordered separately:

Machine	AI retrofit kit	Adapter cable
ALS/XLS 2xx	A9516	A9103
ALS 306		
ALX 73x		

Table 3: Article numbers AI and adapter cable

Firmware

Machine	Firmware Machine	Firmware AI
ALS/XLS 2xx	1.17	1.11
ALS 306, ALX 73x (LMA ^[1])	1.17	1.11
XPA 93x	1.00	--

Table 4: Required minimum firmware versions for machine and AI.

Compressed air

The LA-BO should be operated with an air pressure of 5-6 bar.

CAUTION!
The applied compressed air must match the following conditions to assure proper operation of the applicator:

- ▶ The maximum air pressure must not exceed 6 bar! A higher pressure can damage the device.
- ▶ The air pressure must be kept constant to ensure the correct operation of the applicator.

¹ LMA = Dispenser part of the machine

Start signal

- ALS/XLS 2xx, ALS 306

▶ Connect the start signal to the M12-connector “Start”.

For details see installation manual XLS 2xx or ALS 306, chapter “Installation and Deinstallation” > “Connecting the sensors” > “Start (product) sensor”.

- ALX 73x

▶ Connect the start signal to the M12-connector “Start”.

For details see installation manual ALX 73x, topic section “Installation / Deinstallation”, chapter “Connecting the sensors” > “Start (product) sensor”.

- XPA 93x

▶ Connect the start signal to the M12 connector “Start” (BasicIO board, leftmost).

For details see installation manual XPA 93x, chapter “Commissioning” > “Electrical Connections” > “Connecting the start sensor”.

COMPONENT OVERVIEW (XLS 2XX, ALS 306, ALX 73X)

Front side

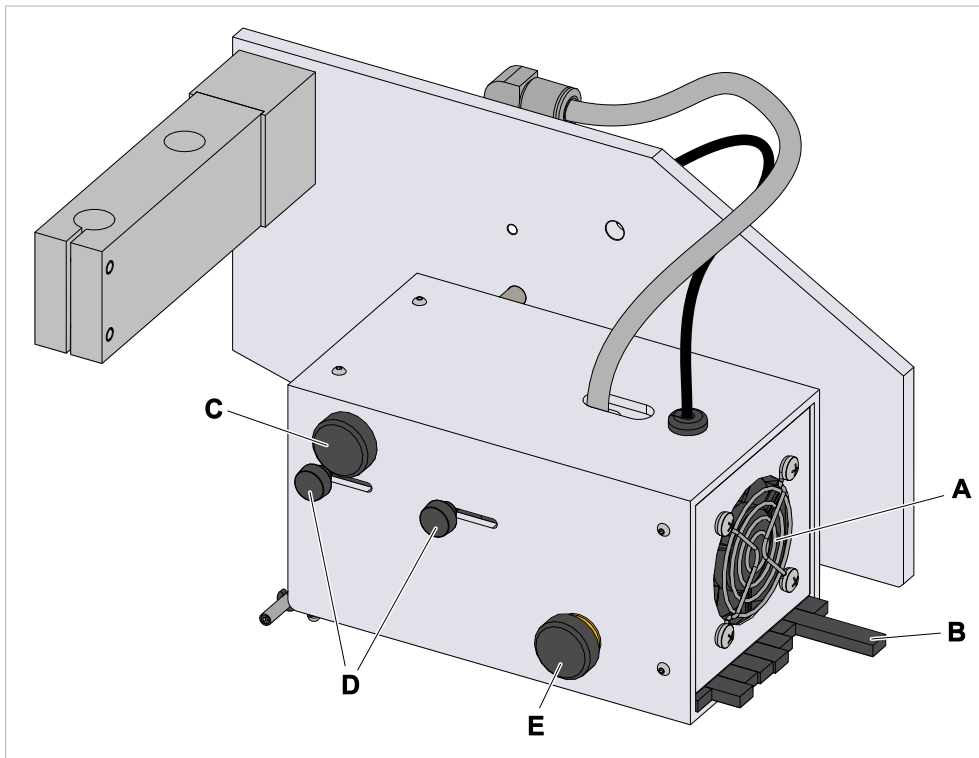

Fig. 1: Control elements on the front side of the LA-BO (here: version for ALS/XLS 2xx, ALS 306 and ALX 73x).

Pos.	Name
A	Fan
B	Sliding bars

Pos.	Name
C	Knob for unlocking the swivelling mechanism
D	Knobs for adjusting the air nozzles in feed direction
E	Knob for adjusting the air nozzles across feed direction

Rear side

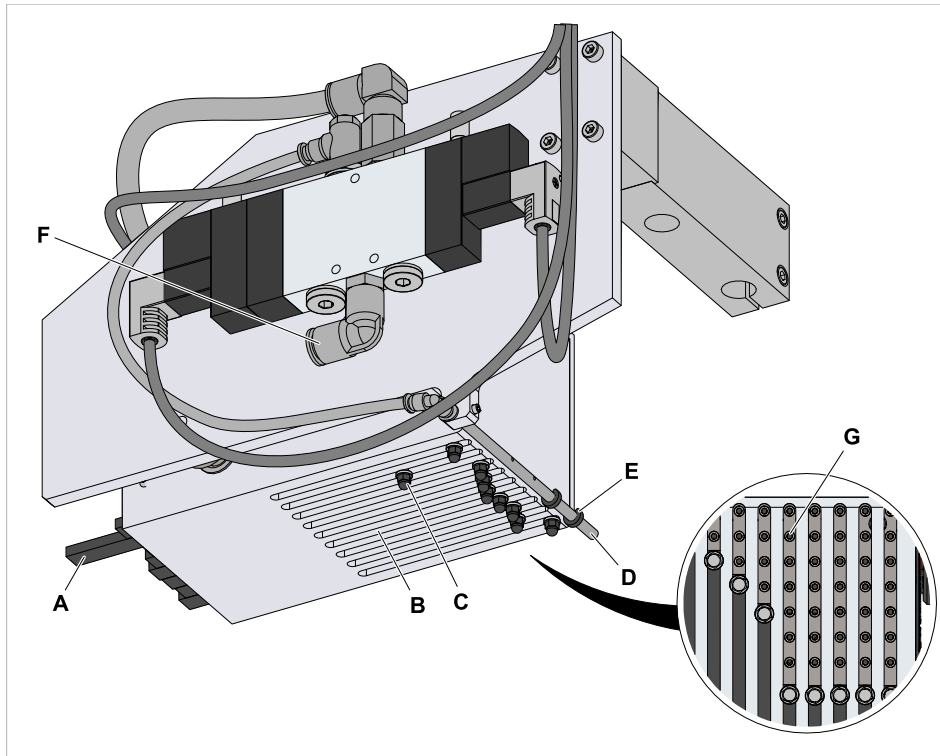

Fig. 2: Control elements on the rear side of the LA-BO (here: version for ALS/XLS 2xx, ALS 306 and ALX 73x).

Pos.	Name
A	Sliding bars
B	Vacuum grid
C	Knob at the sliding bar
D	Blow pipe
E	Ring to close off holes in the blow pipe
F	Connection for compressed air supply hose
G	Air nozzle

COMPONENT OVERVIEW (XPA 93X)

Front side

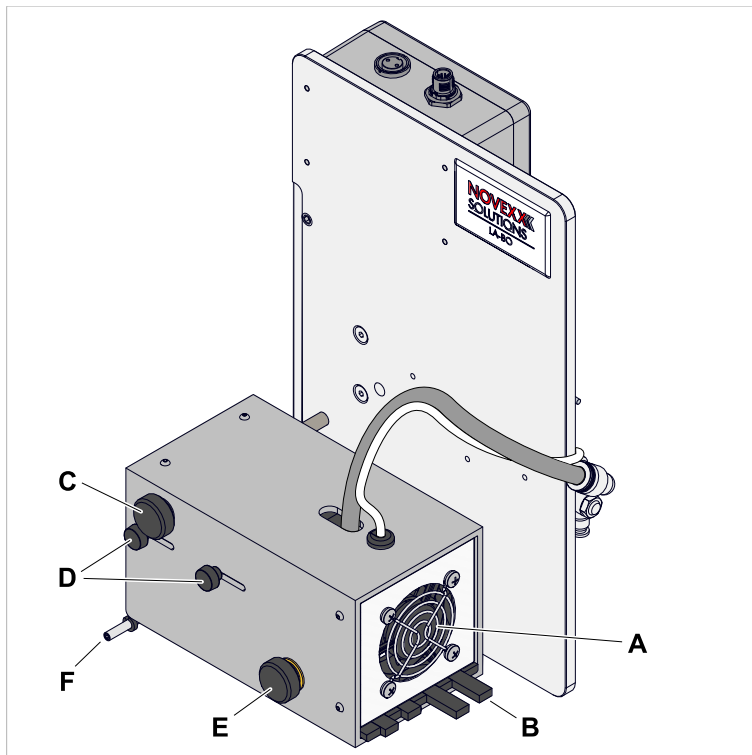

Fig. 3: Control elements on the front side of the LA-BO (here: version for XPA 93x).

Pos.	Name
A	Fan
B	Sliding bars
C	Knob for unlocking the swivelling mechanism
D	Knobs for adjusting the air nozzles in feed direction
E	Knob for adjusting the air nozzles across feed direction
F	Blow pipe

Rear side

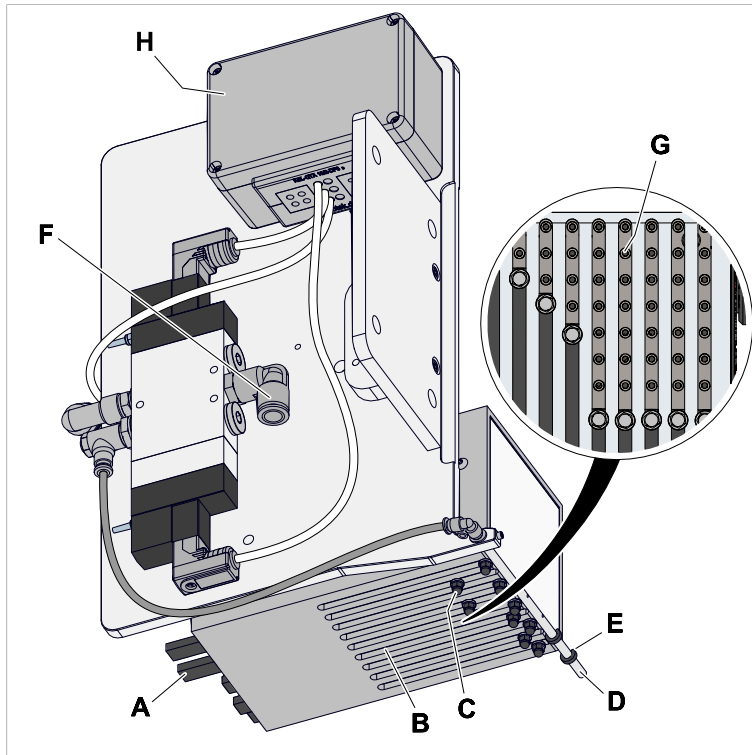

Fig. 4: Control elements on the rear side of the LA-BO (here: version for XPA 93x).

Pos.	Name
A	Sliding bars
B	Vacuum grid
C	Knob at the sliding bar
D	Blow pipe
E	Ring to close off holes in the blow pipe
F	Connection for compressed air supply hose
G	Air nozzle
H	Connection box

TECHNICAL DATA

Material type	Self-adhesive labels of paper, PE or PP
Label size	Min. 30 x 30 mm Max. 100 x 100 mm
Application distance	Min. 20 mm Max. 100 mm ^[2]
Application capacity	Up to 160 labels/min ^[3]
Product speed	From 0 up to 120 m/min ^[4]
Application angle	90° +/- 10°
Application accuracy	Typically +/- 1 mm
Control	Standard signal interface, Applicator Interface or 8IO interface (see chap. System requirements on page 8)
Compressed air	5-6 bar
Air consumption	Approx. 1 liter per apply cycle
Dimensions (LxWxH)	XPA 93x: 215 x 246 x 347 mm XLS 2xx, ALS 306, ALX 73x: 300 x 185 x 180 mm
Weight	3.5 kg
Environmental conditions	Enclosed rooms Working temperature: 5 to 40°C Storage temperature: 0 to 60°C Relative humidity: 30 to 80%, non-condensing
Protection class	IP 21
Power consumption	15 VA
Supply voltage	24 V DC (from ALX or ALS)
Noise level	82 dB(A) during blow cycle

² Depending on label size.

³ Depending on label size and time necessary for trailing edge of label to be released from backing paper.

⁴ Depending on label size, blow distance, productsurface and accuracy.

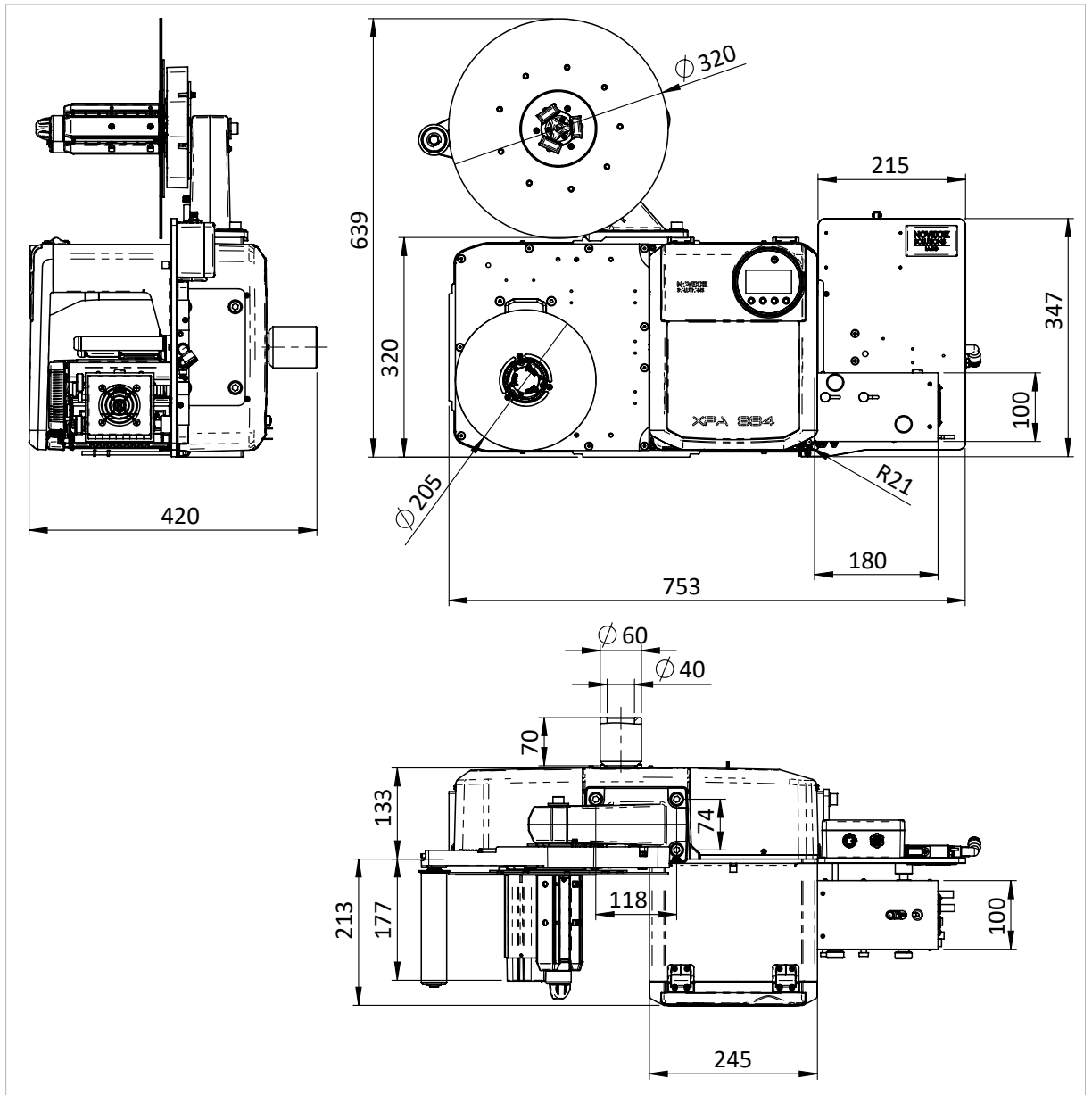

Fig. 5: LA-BO at XPA 934.

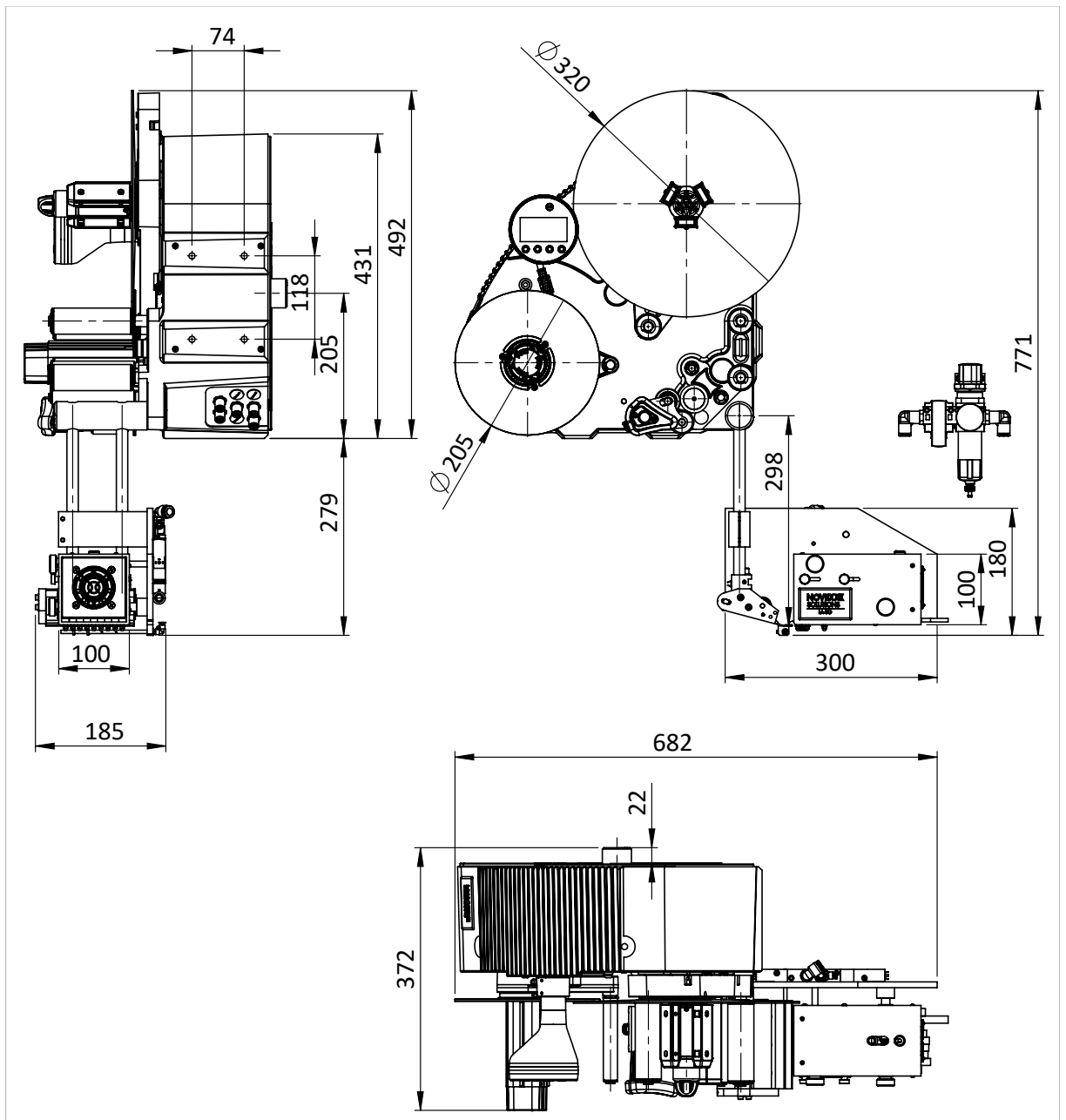

Fig. 6: LA-BO at XLS 204.

Startup

MOUNTING & SETTING ON ALS/XLS 2XX, ALS 306 OR ALX 73X

Mounting

This chapter describes how to mount the LA-BO to an ALS/XLS 2xx, ALS 306 or ALX 73x machine. The pictures show an XLS 20x (RH), but the procedure is the same for the other listed machine types. For article numbers refer to chapter **Machine type** on page 8.

Before you begin

Tools:

- Allen key 3 mm
- Small size screwdriver

Procedure

1. Remove the pressure roller (A) from the dispensing edge and then remove the dispensing edge (B) from the dispensing edge holder by loosening the M8 screw (D). Remove the black bracket (C) from the dispenser rods by releasing the 2 M5 screws at the bottom side.

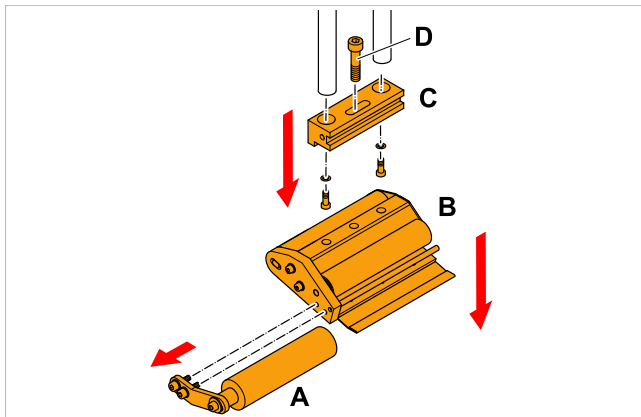

- Slide the aluminium bracket of the LA-BO over the 2 dispenser arm rods (A) and tighten the screws (B).

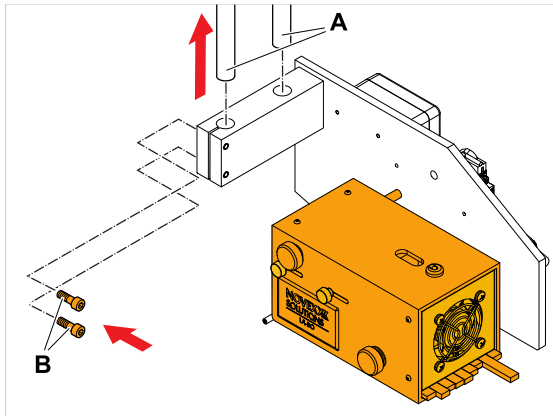

- Remount the black bracket (A) on the dispenser arm rods and adjust the height of the LA-BO so that there's a distance of approximately 39 mm to the black bracket for the dispensing edge. Re-mount the dispensing edge (B) to the black bracket at the dispensing edge holder.

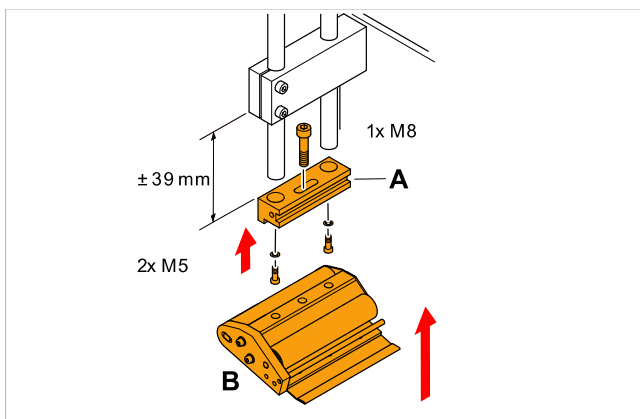

- Plug the cable of the LA-BO into the (44 pin) D-sub connector in the AI-board at the back side of the machine. Alternatively, plug the cable into the D-Sub 15 connector when using internal applicator interface (adapter connector A9103 necessary).

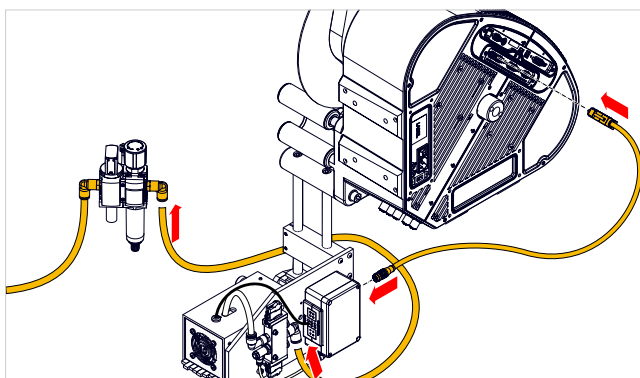

- Mount the supplied service unit near the LA-BO, e.g. on the support stand of the machine. For more information on mounting, see chapter **Installing the service unit** on page 22.
- Connect the LA-BO to the service unit. Connect the compressed air line to the service unit. For more information, see chapter **Connecting compressed air** on page 23.

Adjustment/Setting

Adjusting the dispensing edge to the vacuum grid

After fitting the applicator, the position of the vacuum grid of the applicator in relation to the dispensing edge must be verified and adjusted if necessary. When viewed from the side, the bottom surface of the vacuum grid must be slightly below and in front of the dispensing edge (figure below).

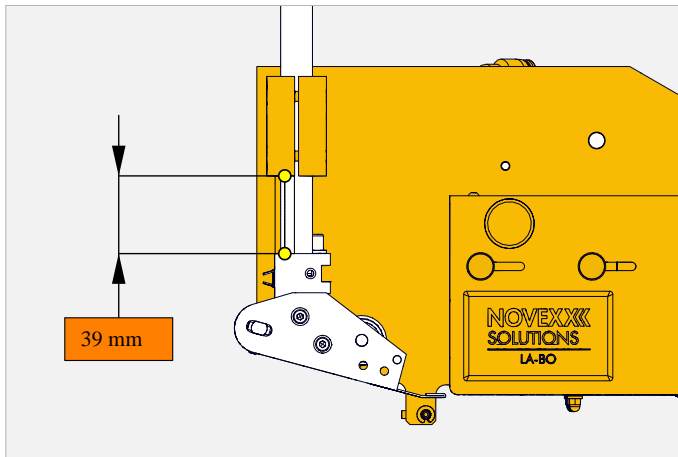

Fig. 7: Position of dispensing edge to vacuum grid.

As a guideline, the vacuum grid surface should be positioned approximately 1 mm *below* the center of the dispensing edge.

To adjust:

- ▶ Adjust the position of the applicator so that the lower edge of the mounting block on the rods is 39 mm above the black end piece (picture above).

Standard signal interface - parameter settings

The parameter settings required for operating the LA-BO applicator controlled by the *standard signal interface*:

Menu	Parameter	Setting
LABEL SETUP	Lab. stop offset	19.0 mm (also depending on distance of label sensor to disp. edge, label must be entirely dispensed)
SIGNAL INTERFACE	Interface mode	„Applic. signals“
SIGNAL INTERFACE >APPLIC. SIGNALS	Apply mode	„After start sig.“ (preferred setting for maximum output capacity)
	Blow on time	60 ms

AI - parameter settings

The parameter settings required for operating the LA-BO applicator controlled by the *applicator interface* (AI).

|| The SIGNAL INTERFACE >>AI BOARD SIGNAL menu appears, if an AI is installed *and* if SIGNAL INTERFACE > Interface mode is set to „Applic. signals“.

Menu	Parameter	Setting
LABEL SETUP	Lab. stop offset	19.0 mm (also depending on distance of label sensor to disp. edge, label must be entirely dispensed)
SIGNAL INTERFACE	Interface mode	„Applic. signals“
SIGNAL INTERFACE >AI BOARD SIGNAL	Apply mode	„After start sig.“ (preferred setting for maximum output capacity)
	Blow on time	60 ms

Related reference

[Adjustments to the label material](#) on page 24

MOUNTING & SETTING ON XPA 93X

Montage

This chapter describes how to mount the LA-BO to an XPA 93x machine. The pictures show an XPA 93x (RH). For article numbers refer to chapter [Machine type](#) on page 8.

Before you begin

Tool:

- Allen key, 8 mm

Procedure

1. Screw the applicator to the flange of the XPA 93x using the supplied screws (4x M10x25):

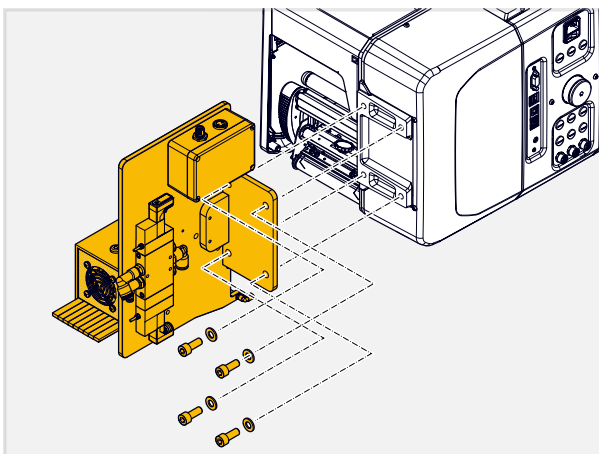

2. Connect the supplied cable to the connection box of the LA-BO and to the left connection of the 8IO board on the XPA 93x:

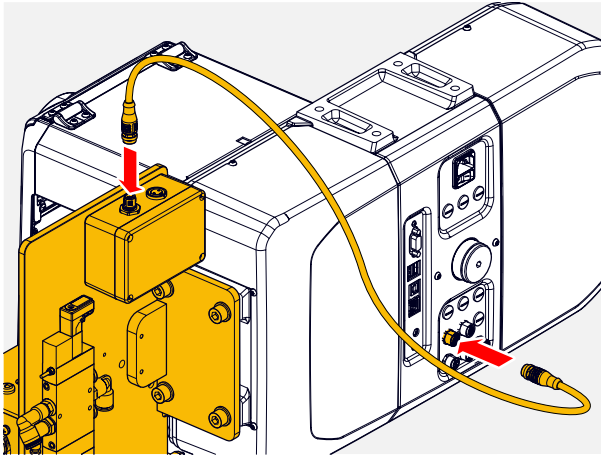

3. Mount the supplied service unit near the LA-BO, e.g. on the support stand of the machine. For more information on mounting, see chapter **Installing the service unit** on page 22.
4. Connect the LA-BO to the service unit. Connect the compressed air line to the service unit. For more information, see chapter **Connecting compressed air** on page 23.

Adjustment/Setting

Parameter settings on the XPA 93x

Menu	Parameter	Setting
Dispenser	Dispenseposition	0 mm (label must be entirely dispensed)
	Dispensing edge	short
	Application mode	“Save mode”
Options > Selection > Applicator	Applicator type	LA-BO
Options > LA-BO	Apply mode	“After start sig.” (preferred for maximum output capacity)
	Blow on time	60 ms

Related reference

Adjustments to the label material on page 24

INSTALLING THE SERVICE UNIT

The service unit comes with the applicator. It consists of the following parts:

- Manual on-off valve (A)
- Filter regulator (B) with pressure gauge (C)
- Condensate drain (D)

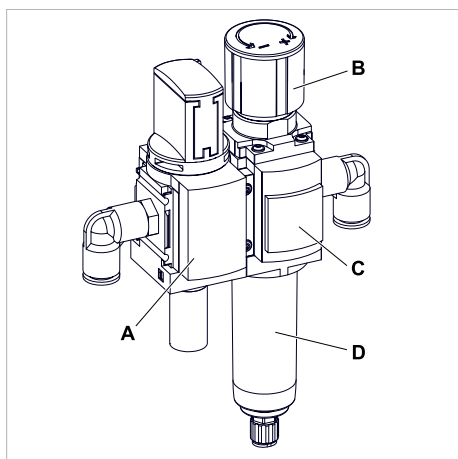

Fig. 8: Components of the maintenance unit.

Before you begin

Tool: 4 mm hex screwdriver

Procedure

1. Screw on the maintenance unit with the enclosed screws (M5x12).

|| The condensate drain (B) must point downwards. ||

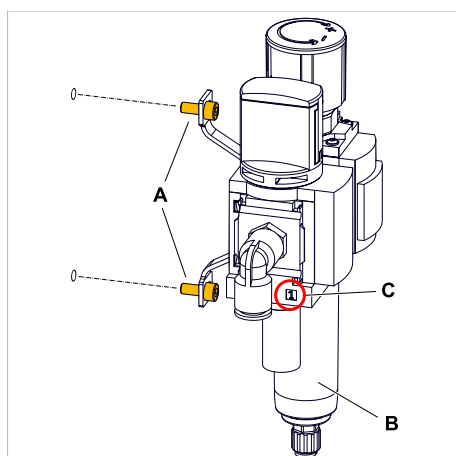

2. Fasten the pressure tubes so that the air flows through the pressure regulator in the direction from mark "1" (image above, C) to mark "2".

|| The connector marked "2" is the compressed air outlet. This must be connected to the applica-
tor. ||

|| Mind the instruction sheet of the manufacturer, which comes with the service unit. ||

CONNECTING COMPRESSED AIR

Before you begin

- Hose diameter: 10 mm
- Maximum admissible compressed air pressure at the service unit *entrance*: 10 bar
- Maximum admissible compressed air pressure at the service unit *exit*: 6 bar

|| Mind the instruction sheet of the manufacturer that comes with the service unit. ||

Procedure

1. Switch off the on-off valve. To do this, turn the rotary knob (A) clockwise as far as it will go

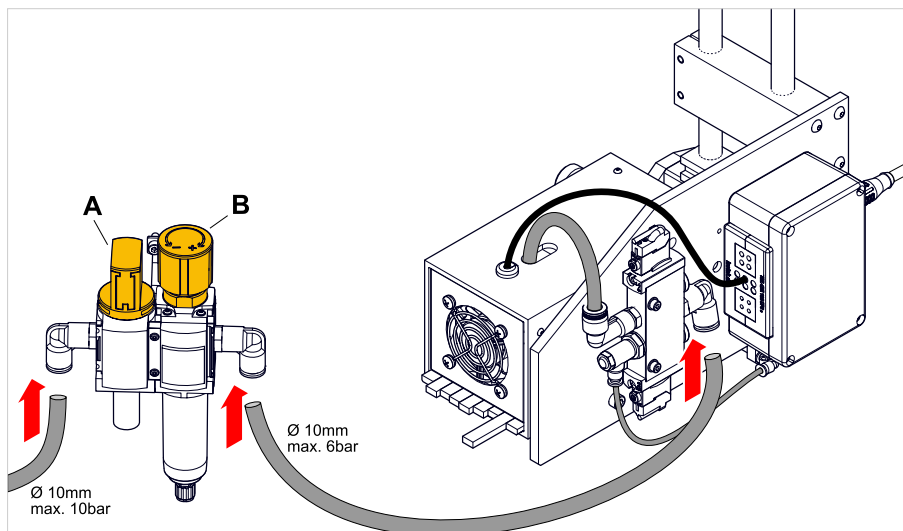

|| Fig. shows LA-BO for ALS/XLS 2xx, ALS 306 or ALX 73x. ||

2. Reduce the outlet pressure completely. To do this, turn the control valve knob (fig. above, B) all the way to "-".
3. Connect the compressed air line to the connections as shown (fig. above).
4. Switch on the compressed air.
5. Switch on the on-off valve. To do this, turn the rotary knob (fig. above, A) counterclockwise as far as it will go.
6. Set the outlet pressure. To do this, slowly turn the control valve knob (fig. above, B) in the "+" direction until the pressure gauge indicates the desired outlet pressure.

ADJUSTING THE APPLICATION HEIGHT

In general, to obtain a good apply accuracy of the label on the product, it is recommended to adjust the LA-BO as close as possible to the product surface.

CAUTION!

Hazard of collision between the conveyed products and the LA-BO.

Possible consequences: Damages at LA-BO and/or products respectively impairment of production output.

- ▶ When adjusting the label height, provide a safe distance between LA-BO (especially the support air nozzle) and products on the conveyor.
- ▶ Consider variations in product height, when adjusting the height of the LA-BO.

The labelling distance of the LA-BO to the product surface may vary between 20 mm and maximum 100 mm.

- ▶ Adjustment of the LA-BO application height is done by adjusting the mounting height of the machine.

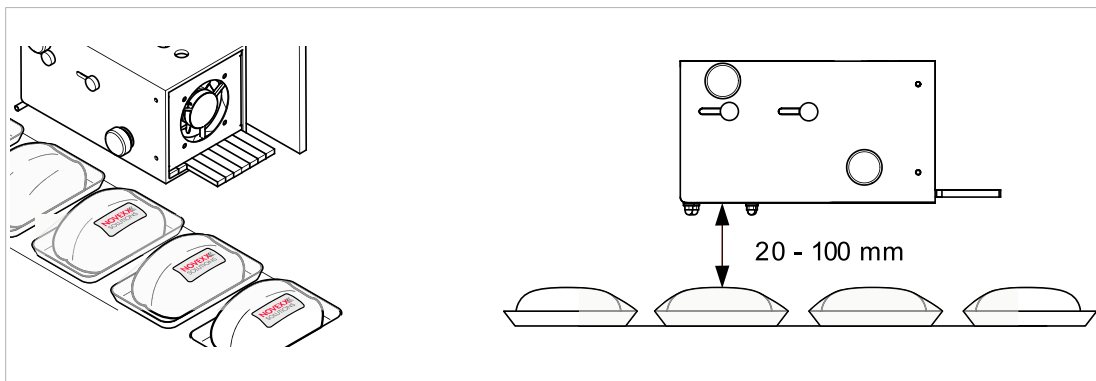

Fig. 9: Labelling distance between LA-BO and product.

ADJUSTMENTS TO THE LABEL MATERIAL

The following settings must be made each time the label format processed on the machine is changed.

Adjusting the sliding bars in the vacuum grid

About this task

Because the LA-BO needs to create a strong air flow, evenly spread over the label surface, it is important to adjust the sliding bars of the vacuum grid. Once this setting is done, the sliding bars will close off the air nozzles which are positioned outside the label area.

Procedure

1. Push back the sliding bars (A) completely:

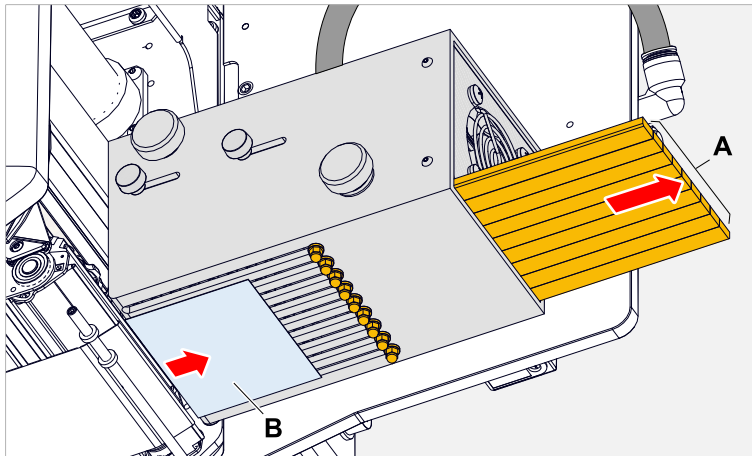

2. Dispense a single label (fig. above, B) on the vacuum grid of the applicator.

The label is not dispensed straight on the grid or still sticks with the trailing edge on the dispenser?

► Check the height adjustment of the dispenser in relation to the vacuum grid.

3. Carefully adjust the bars to the label size by moving the knobs (A) just against the label edge, without touching the edge of the label. Bars outside the width of the label should be fully moved inwards the vacuum grid (B) so all the air nozzles (C) above this bar are closed.

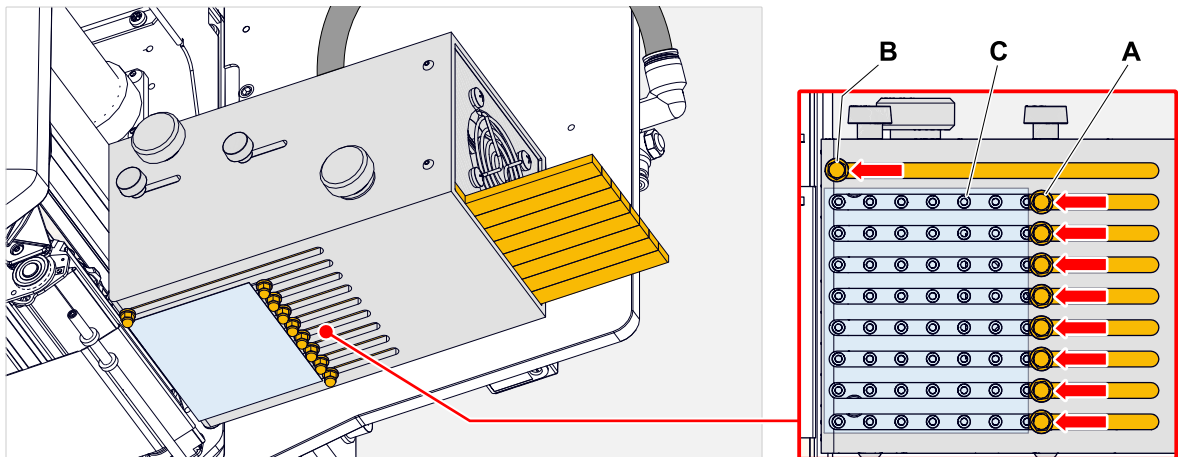

4. Proceed some dispensing tests and check if the knobs on the bars are not touching or holding the edge of the dispensed label.

Alternative setting method:

5. In most applications with a blow-on applicator, it will be difficult to visually verify the position of the sliding bars from the bottom side of the vacuum grid. Therefore, the bars can also be adjusted by matching the section of the bars outside the vacuum grid to the label surface.

Matching the section of the bars (A) outside the vacuum grid to the label surface (B):

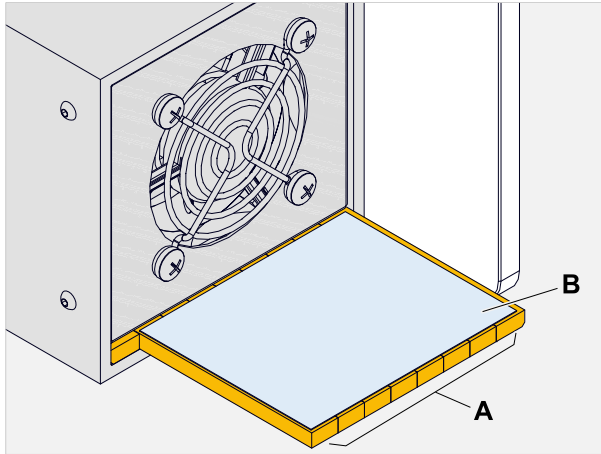

Adjusting the air nozzles in the vacuum grid

To achieve optimal labelling apply accuracy it is important to adjust the blow-off air flow in the center of the label under the vacuum grid. Therefore the air nozzles of the LA-BO can be fine adjusted in the X (width) and Y (length) direction in reference to the label area.

To adjust the air nozzles in X-direction (width of label)

- ▶ Turn the black lower-right knob (A) clockwise or counter clockwise until the sliding bars / nozzles are centered over the width of the label.

This setting becomes more critical for smaller label sizes. If the non-closed nozzles are not centered over the width of the label, the label will move sideways during the blow-on action.

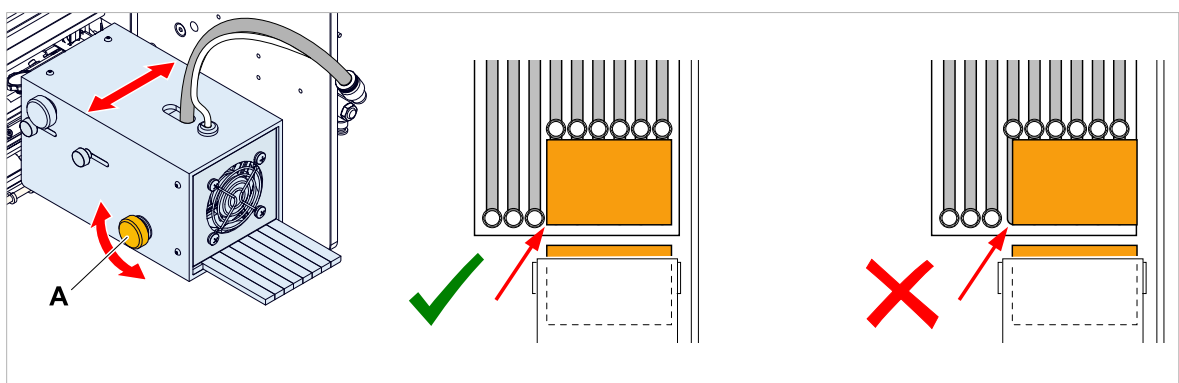

Fig. 10: Adjusting the air nozzles across feeding direction.

To adjust the air nozzles in Y-direction (length of label)

1. Loosen the 2 small black knobs (A) and slide them in a direction as follows:
 - Label length < 75 mm: Slide knobs towards the dispensing edge
 - Label length > 75 mm: Slide knobs away from the dispensing edge

2. Retighten the 2 small black knobs.
3. (Optional) Small label formats (less than 40 mm width): Check if the open nozzles are centered over the width of the label.

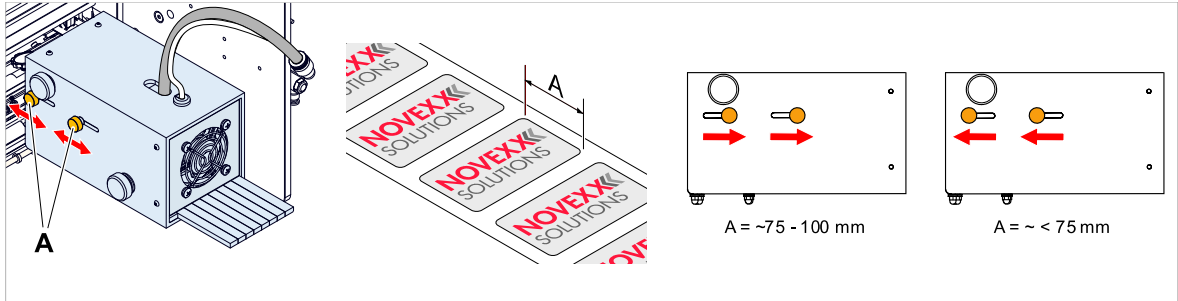

Fig. 11: Adjusting the air nozzles in feeding direction.

Adjusting the air stream support

The small brass blow pipe creates an air stream during the dispensing of the label to support the label towards the vacuum grid of the LA-BO. It is necessary to adjust the position of the blow pipe to obtain an aligned and straight label transport to the vacuum grid.

Before you begin

Tool: Allen key 2.5 mm

Procedure

1. Loosen the set screw (A) at the support air nozzle:

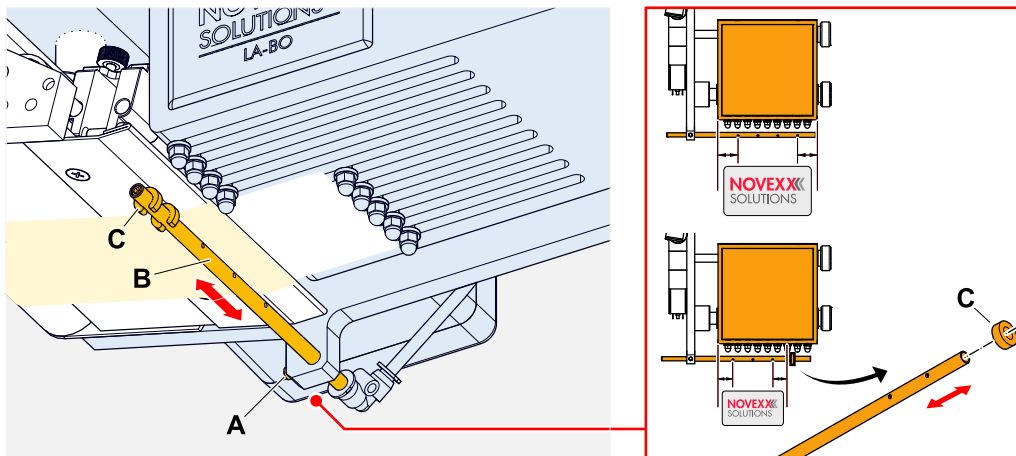

2. Adjust the support air nozzle (B, picture above) so the maximum number of air holes are centered to the label width.

If there are air holes outside the width of the label, they should be closed off by the red rings (C, picture above).

The air holes in the blow pipe should be directed to the vacuum grid.

3. Retighten the threaded pin to fix the blowpipe.

Setting the dispensing position parameter

When using the LA-BO applicator the dispensing stop position of the machine should be set so that the label is just released when dispensed, i.e. so that it no longer adheres to the carrier material.

If the label is not completely dispensed but is still partially attached to the carrier material, the label will be blown off side ways, or upside down or will not be blown off by the LA-BO.

Advancing the carrier material too far can cause the label be pulled back under the dispensing edge in case of strong adhesive or the following label can come in contact with the dispensed label.

Related reference

[Adjustment/Setting](#) on page 19

[Adjustment/Setting](#) on page 21

Operation

ACTIVATING/DEACTIVATING THE APPLICATOR

Activating

In *normal operation* mode, the applicator is supplied with compressed air by the plant in which it is integrated.

1. (If the rotary knob of the on-off valve is secured with a padlock) Open the lock and remove it.
2. Turn the rotary knob of the on-off valve on the service unit counterclockwise as far as it will go (90°):

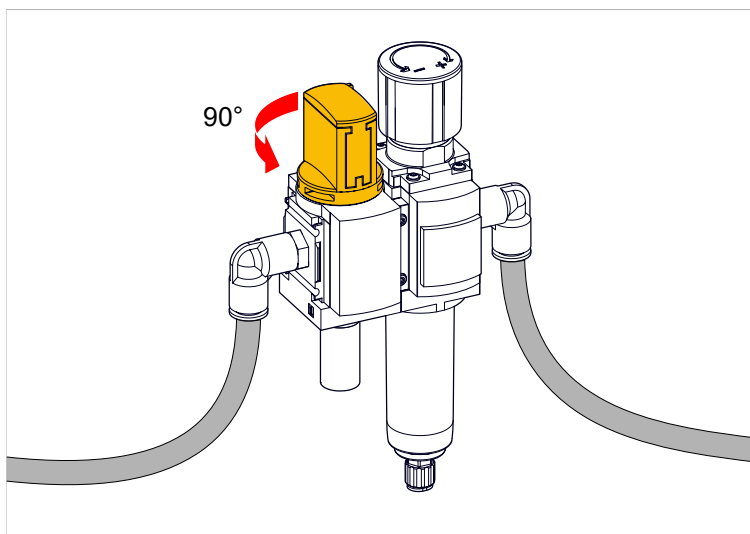

Fig. 12: Opening the on-off valve at the service unit (fig. shows closed valve).

-
- Control signals are active (machine is online)
- Interlock circuit is closed (protection door is closed)

Deactivating

CAUTION!

After switching off the compressed air supply, the of the applicator moves down into end position. Hazard of damage to the applicator by products passing by.

- ▶ Stop the conveyor or
- ▶ Make sure that no products pass by or
- ▶ Fix the applicator in home position

1. Stop the machine, to which the applicator is attached.
2. Switch off the compressed air supply (using an appropriate switch at the plant or the manual on-off valve at the service unit).

After switching off the compressed air supply, the of the applicator moves down into end position.

CLEANING

Safety



WARNING!

Dangerous situations may arise during maintenance and cleaning work. Accidents may occur due to mechanical or electrical effects if the relevant safety instructions are not observed!

- ▶ Switch off the machine before cleaning or maintenance and completely disconnect it from the main power supply. Depending on the machine type, it may be necessary to pull out the mains power connecting line (refer to the user manual of the machine)!
- ▶ Never allow liquid to get into the machine!
- ▶ Do not spray the machine with spray bottles or sprays! Use a cloth wetted with cleaning agent!
- ▶ Repairs to the machine must only be made by trained service technicians!

Cleaning interval

- ▶ Clean the machine regularly.

The frequency depends on the following factors:

- Operating conditions
- Daily operating duration

Cleaning instructions

CAUTION!

Using sharp cleaning materials may cause damage.

- ▶ Do not use any cleaning agents or materials that could damage or destroy the paint finish, labelling, type plates, electrical component, etc.
- ▶ Do not use any scouring cleaning agents or any cleaning agents that could dissolve plastic.
- ▶ Do not use acid or alkaline solutions.

Cleaning agents:

- Compressed air, vacuum cleaner (if available)
- White spirit (ethanol) or isopropyl alcohol

Proceeding:

- ▶ Blow away or suck off any dust and abrasive particles with compressed air or a vacuum cleaner (if any of the two is available)
- ▶ Moisten a cloth with white spirit and wipe the machine with it.

FAULT CORRECTION

Status

In the event of faults occurring on the machine, evaluate the status reports of the print & apply system respectively of the labeler before doing anything.

Read the user manual of the print & apply system or of the labeler, topic section „Status Reports“ or „Operational failures“.

Call service

If you are not authorised to carry out diagnosis and fault correction work, call your technician or the authorised service. The appropriate documentation and spare parts are available to the service personnel in order to carry out repair work of a sufficient quality.

Appendix

PNEUMATIC DIAGRAM

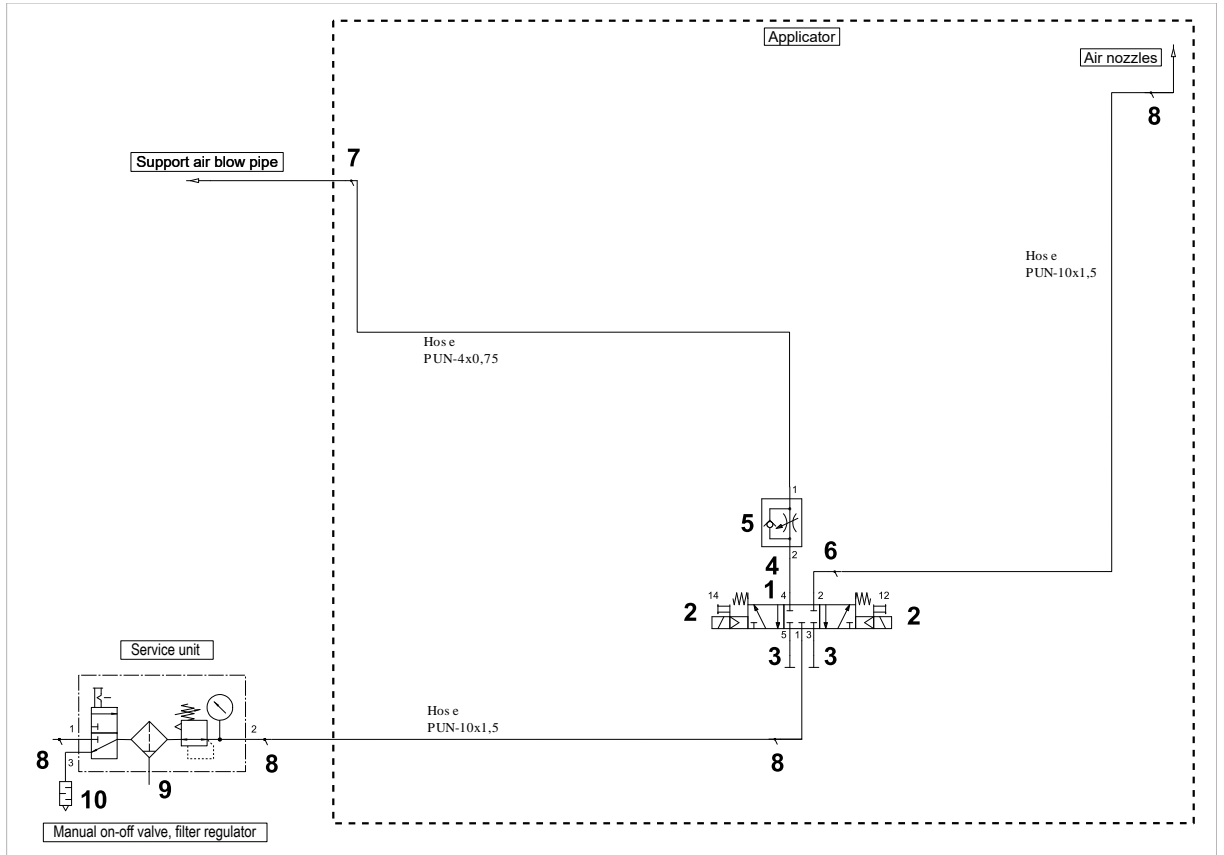

Fig. 13: Pneumatic diagram LA-BO

Pos. no.	Article no.	Amount	Designation
1	N104069	1	Solenoid valve
2	N104070	1	Solenoid valve connection cable
3	A8804	2	Plug
4	A8808	1	Reducing nipple
5	A8805	1	Check valve with choke
6	8803	1	Push-in long L-fitting
7	A8810	1	Push-in L-fitting
8	A8806	4	Push-in L-fitting
9	N104061	1	Service unit
10	N104062	1	Silencer

EU DECLARATION OF INCORPORATION

(Translation of original version)

We, Novexx Solutions GmbH
 Ohmstraße 3
 D-85386 Eching
 Germany

hereby declare that the partly completed machine designated below has been designed and built in such a way as to be in conformity with the safety and health protection requirements of directive 2006/42/EC, annex I, which are marked „fulfilled“ in the following table „Appendix regarding the Declaration of Incorporation“.

The special technical documents in accordance with appendix VII part B of directive 2006/42/EC have been created. We undertake to forward the special technical documentation in respect of the partly completed machine to national authorities at their request. We shall submit them by means of electronic data carrier.

The partly completed machine designated herein is furthermore in compliance with the provisions of directive 2014/30/EU (EMC) and directive 2011/65/EU(RoHS, in the currently valid version).

The designated partly completed machine must not be placed in operation until it has been determined that the machine in which the partly completed machine has been installed is in compliance with the provisions of directive 2006/42/EG.

Models	LA-TO / LA-TO XL LA-TO touch down / LA-TO XL touch down LA-TO BO / LA-TO BO XL LTP / LTPV LA-SO LA-BO LTSI / LTSA / LTMA
General designation	Applicator
Applicable EU directive	2006/42/EG (Machinery) 2014/30/EU (EMC) 2011/65/EU (RoHS) in the currently valid version
Applied harmonized standards, especially	EN ISO 12100 : 2010 EN ISO 4414 : 2010 EN 62638-1:2024/A11:2017
The person authorized to compile technical documents	Novexx Solutions GmbH (for address see above)

Eching, 4.2.2026

Alfredo Sansone
 Head of Supply Chain and Operations and Compliance

Appendix regarding the Declaration of Incorporation

List of the essential health and safety requirements applied and fulfilled for the product named in the declaration of incorporation, relating to the design and construction of machinery.

Number Annex I	Designation	Not applicable	Fulfilled	Remark
1.1	General remarks			
1.1.2.	Principles of safety integration		X	
1.1.3.	Materials and products		X	
1.1.4.	Lighting	X		
1.1.5.	Design of machinery to facilitate its handling		X	
1.1.6.	Ergonomics	X		
1.1.7.	Operating positions	X		
1.1.8.	Seating	X		
1.2.	Control systems			
1.2.1.	Safety and reliability of control systems	X		
1.2.2.	Control devices	X		
1.2.3.	Starting	X		
1.2.4.	Stopping			
1.2.4.1.	Normal stop	X		
1.2.4.2.	Operational stop	X		
1.2.4.3.	Emergency stop	X		
1.2.4.4.	Assembly of machinery	X		
1.2.5.	Selection of control or operating modes	X		
1.2.6.	Failure of the power supply		X	
1.3.	Protection against mechanical hazards			
1.3.1.	Risk of loss of stability	X		
1.3.2.	Risk of break-up during operation		X	
1.3.3.	Risks due to falling or ejected objects	X		
1.3.4.	Risks due to surfaces, edges or angles		X	
1.3.5.	Risks related to combined machinery	X		
1.3.6.	Risks related to variations in operating conditions	X		
1.3.7.	Risks related to moving parts			Requires protective device [5]

⁵ Installation by the system integrator

Number Annex I	Designation	Not applicable	Fulfilled	Remark
1.3.8.	Choice of protection against risks arising from moving parts			
1.3.8.1.	Moving transmission parts	X		
1.3.8.2.	Moving parts involved in the process			Requires protective device ^a
1.3.9.	Risks of uncontrolled movements	X		
1.4.	Required characteristics of guards and protective devices			
1.4.1.	General requirements			a
1.4.2.	Special requirements for guards			
1.4.2.1.	Fixed guards	X		
1.4.2.2.	Interlocking movable guards			a
1.4.2.3.	Adjustable guards restricting access	X		
1.4.3.	Special requirements for protective devices	X		
1.5.	Risks due to other hazards			
1.5.1.	Electricity supply		X	
1.5.2.	Static electricity		X	
1.5.3.	Energy supply other than electricity		X	
1.5.4.	Errors of fitting		X	
1.5.5.	Extreme temperatures		X	
1.5.6.	Fire		X	
1.5.7.	Explosion	X		
1.5.8.	Noise		X	
1.5.9.	Vibrations	X		
1.5.10.	Radiation		X	
1.5.11.	External radiation		X	
1.5.12.	Laser radiation	X		
1.5.13.	Emissions of hazardous materials and substances	X		
1.5.14.	Risk of being trapped in a machine	X		
1.5.15.	Risk of slipping, tripping or falling	X		
1.5.16.	Lightning	X		
1.6.	Maintenance			
1.6.1.	Machinery maintenance		X	
1.6.2.	Access to operating positions and servicing points		X	

Number Annex I	Designation	Not applicable	Fulfilled	Remark
1.6.3.	Isolation of energy sources		X	
1.6.4.	Operator intervention		X	
1.6.5.	Cleaning of internal parts	X		
1.7.	Information			
1.7.1.	Information and warnings on the machinery		X	
1.7.1.1.	Information and information devices	X		
1.7.1.2.	Warning devices	X		
1.7.2.	Warning or residual risks		X	
1.7.3.	Marking of machinery		X	
1.7.4.	Instructions		X	
1.7.4.1.	General principles for the drafting of instructions		X	
1.7.4.2.	Contents of the instructions		X	
1.7.4.3.	Sales literature		X	

Telephone: +49-8165-925-0 | www.novexx.com

NOVEXX«
SOLUTIONS

Novexx Solutions GmbH

Ohmstraße 3
85386 Eching
Germany