

OPERATING MANUAL

LA-TO xx Applicators

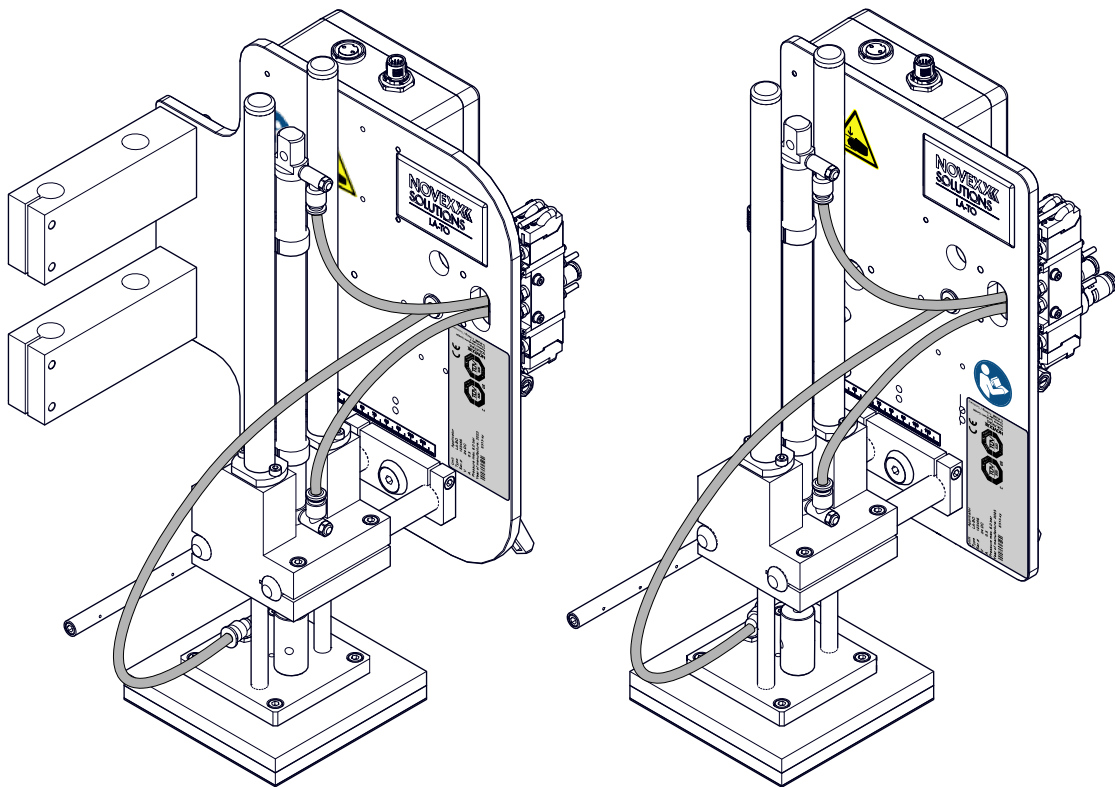

Contents

Please Note - 4

General Information - 4

Validity of this manual and required compliance - 4

How information is represented - 5

For your safety - 6

Intended use - 6

Information and qualification - 6

Safety functions - 7

Operating safety of the machine - 11

Warning notes on LA-TO - 13

Product description - 14

Technical Data - 14

Overview - 16

Product name - 16

System requirements - 17

Configurations - 18

Functionality - 19

Component overview - 20

Parameters - 22

(XPA 93x) Applicator-parameters in the parameter menu - 22

(XLS 2xx) Applicator-parameters in the parameter menu - 22

Parameter Reference (Applicators) - 24

Startup - 28

Assembly - 28

Preparing the connection cable for the interlock circuit - 28

Mounting on XPA 93x - 28

Mounting on XLS 2xx - 31

Installing the service unit - 34

Connecting the compressed air - 35

Connecting the compressed air (alternative way) - 36

Selecting the size of the vacuum plate - 38

Parameter settings - 39

Mechanical adjustments - 41

Adjusting the lateral position of the pressure plate - 41

Adjusting the distance between pressure plate and dispensing edge - 43

Operation - 45

Activating/deactivating the applicator - 45

Cleaning - 46

Fault correction - 47

Appendix - 48

Pneumatic diagrams - 48

Overview: holes in the pressure plates - **50**

EU Declaration of Incorporation - **51**

Index of parameter names and error messages - 55

Please Note

GENERAL INFORMATION

Validity of this manual and required compliance

Contents

Manual	Target group	Medium	Availability
Operating manual	Operating personnel Service personnel	PDF file	NOVEXX Solutions website www.novexx.com
Service manual	Service personnel		NOVEXX Solutions Partner Portal https://partner.novexx.com
Spare parts catalogue			

The present *operating manual* describes the installation and operation of the named applicator. For safe and proper operation of the print- & apply system with attached applicator, it is indispensable to consult the operating manual for the relevant print- & apply system too.

For technical questions not covered in this manual:

- ▶ Follow the instructions of the service manual for the applicator and for the applied print & apply system or
- ▶ Request a service technician from our sales partner.

NOVEXX Solutions customer service department is available especially for configuration settings and malfunctions.

Liability

NOVEXX Solutions reserves the right:

- To make changes in design and components, and to use equivalent other parts than those specified in line with technological progress.
- To change information in this manual.

Any obligation to extend these changes to machines previously delivered is excluded.

Copyright

NOVEXX Solutions retains all rights to this manual and its appendices. Reproduction, reprint or any other type of duplication, including parts of the manual, are permitted only with written approval.

Manufacturer

Novexx Solutions GmbH
 Ohmstrasse 3
 D-85386 Eching, Germany
 Tel.: +49-8165-925-0
www.novexx.com

How information is represented

Explanation of symbols

To enhance readability and make information easier to find, different types of information are identified:

▶ Instruction with no order of tasks assigned

1. Numbered instructions introduced by preceding text
2. The specified order must be followed!

|| Note.

- Enumeration of features
- Other feature

 The Experts symbol identifies activities that are reserved exclusively for qualified and specially trained personnel.

Warning Notes

Warning notes are specially highlighted:



WARNING!

Warning notes with the signal word **WARNING** refer to risks that can result in severe or fatal injuries! The note contains safety measures to protect affected persons.

- ▶ Instructions must be followed without exception.

CAUTION!

Warning notes with the signal word **CAUTION** refer to risks that can result in property damage or personal injury (minor injuries). The note contains instructions for preventing damage.

- ▶ Instructions must be followed without exception.

Illustrations

Illustrations appear in the text where required. References to the illustrations are shown in brackets, if necessary (see table).

Reference to illustration	Application
none	<ul style="list-style-type: none"> • Only one illustration • Reference to the illustration is obvious • No position number in the illustration
(A)	<ul style="list-style-type: none"> • Only one illustration • Reference to the illustration is obvious • Position number in the illustration
(see fig. above)	<ul style="list-style-type: none"> • Several illustrations • No position number in the illustration
(see fig. above, pos. A)	<ul style="list-style-type: none"> • Several illustrations • Position number(s) in the illustration

Table 1: Different references to illustrations.

Parameters

Parameters in the parameter menu are represented in the format **Menu name > Parameter name** in grey type.

FOR YOUR SAFETY

Intended use



WARNING!

The device described here is „partly completed machinery“ as defined by machinery directive 2006/42/EC!

► Do not set the applicator in operation until it has been determined that the machine in which the applicator will be installed meets the requirements of directive 2006/42 EC, appendix IIA.

The LA-TO applicator is a device for automatic attachment of self-adhesive labels, which are supplied to the applicator by one of the following labelers or print & apply systems (called “machine” in the following):

Labelers:

- XLS 204
- XLS 206
- XLS 256
- XLS 272

Print- & Apply Systems:

- XPA 93x

The LA-TO is firmly attached to the respective machine. In contrast to direct dispensing from the dispensing edge of the machine onto the product, the LA-TO can bridge distances of up to 18 cm (LA-TO XL: 38 cm) between dispensing edge and product.

The LA-TO must not be operated outdoors or in potentially explosive areas (EX areas).

Any other type of or more extensive application will be considered non-intended use. NOVEXX Solutions shall assume no liability for damage resulting from non-intended use of the machine.

Information and qualification

Ensuring the necessary qualification

- Only fully trained and authorised personnel are permitted to operate, adjust and maintain the machine.
- Service work must only be performed by qualified and appropriately trained technical specialists (service technicians) or the customer service department.
- Areas of responsibilities for operating and servicing the machine must be clearly defined and consistently observed.

Qualification for operation

The instruction provided for the operating personnel must ensure:

- That the operating personnel can use the machine independently and without danger.
- That the operating personnel can rectify minor operating faults (for example a paper jam) independently.
- At least 2 persons should be instructed in operation.
- Have a sufficient quantity of label materials available for tests and instruction.

Making note of information

The device can only be operated safely and efficiently by complying with all of the requisite information!

- Carry out the installation, connection, programming, setting, and repairing of the machine exclusively in accordance with the specifications in this manual.
- Before beginning operation, read this operating manual and the user manual of the machine to which the applicator is attached and follow all of the instructions.
- Observe all additional safety and warning information given on the device.
- Only technically knowledgeable persons are permitted to operate the device and make settings on it.

Any product liability and warranty claims will not be valid unless the machine is operated according to the instructions in the operating manual.

Keep product information at hand

This operating manual

- must remain readily available for operating personnel at a location near to the machine.
- The safety and warning symbols and messages on the machine must be kept in a clean and legible state. Replace any signs that are damaged or missing.
- can be downloaded here: <https://www.novexx.com/service-and-support/user-manuals/>



Safety functions



WARNING!

Danger of personal injury and property damage!
Without operational safety functions and protective equipment the applicator may cause personal injury and property damage.

- ▶ Do not operate the machine without protective equipment.
- ▶ Do not operate the machine when the safety functions are deactivated.

Protective equipment

A separating protective device must be installed by the system integrator in compliance with the requirements of EN953. It could be a protective enclosure with a secured door, for example.

The separating protective equipment is not included in the scope of delivery of the machine.

Connecting an interlocking guard

- ▶ Connect the interlock switch of the safeguarding device to the connector (small fig. below) delivered with the applicator.
- ▶ Plug the connector to the switch box (fig. below, B).

Operation of the applicator without the described safeguarding device shall be regarded as abnormal use. NOVEXX Solutions assumes no liability for damage due to abnormal use of the printer.

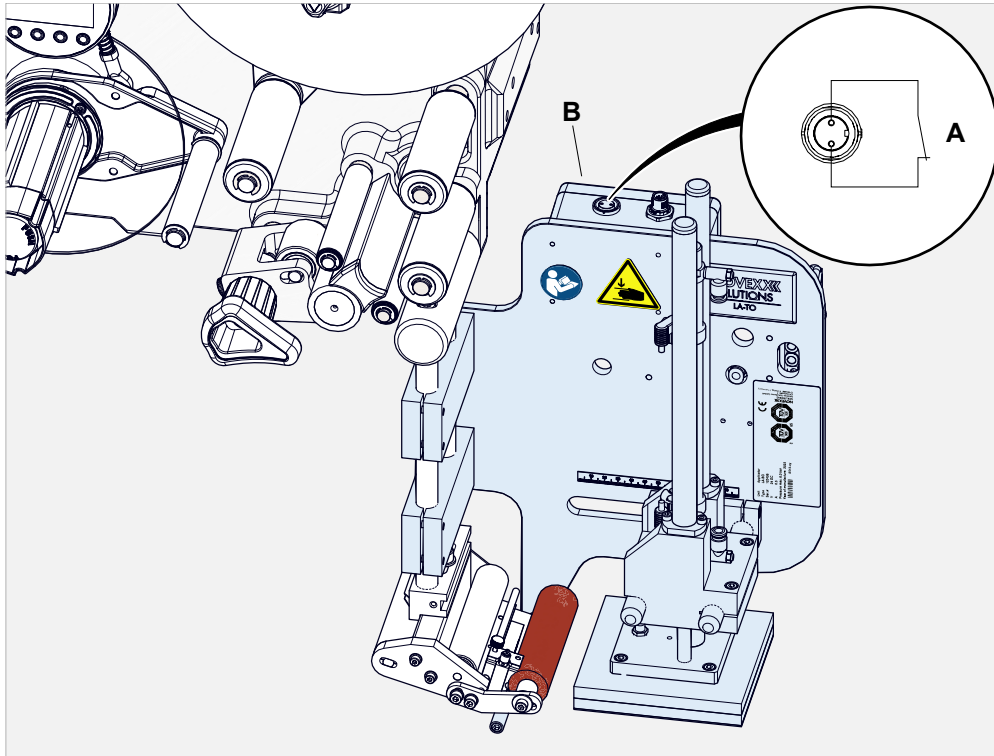

Fig. 1: Connecting the interlock switch (A) of the safeguarding device (or an emergency-stop switch) to a LA-TO.

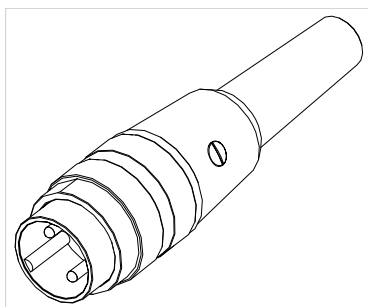

Fig. 2: Plug that comes with the applicator for connecting an interlock switch (article number: A102076).

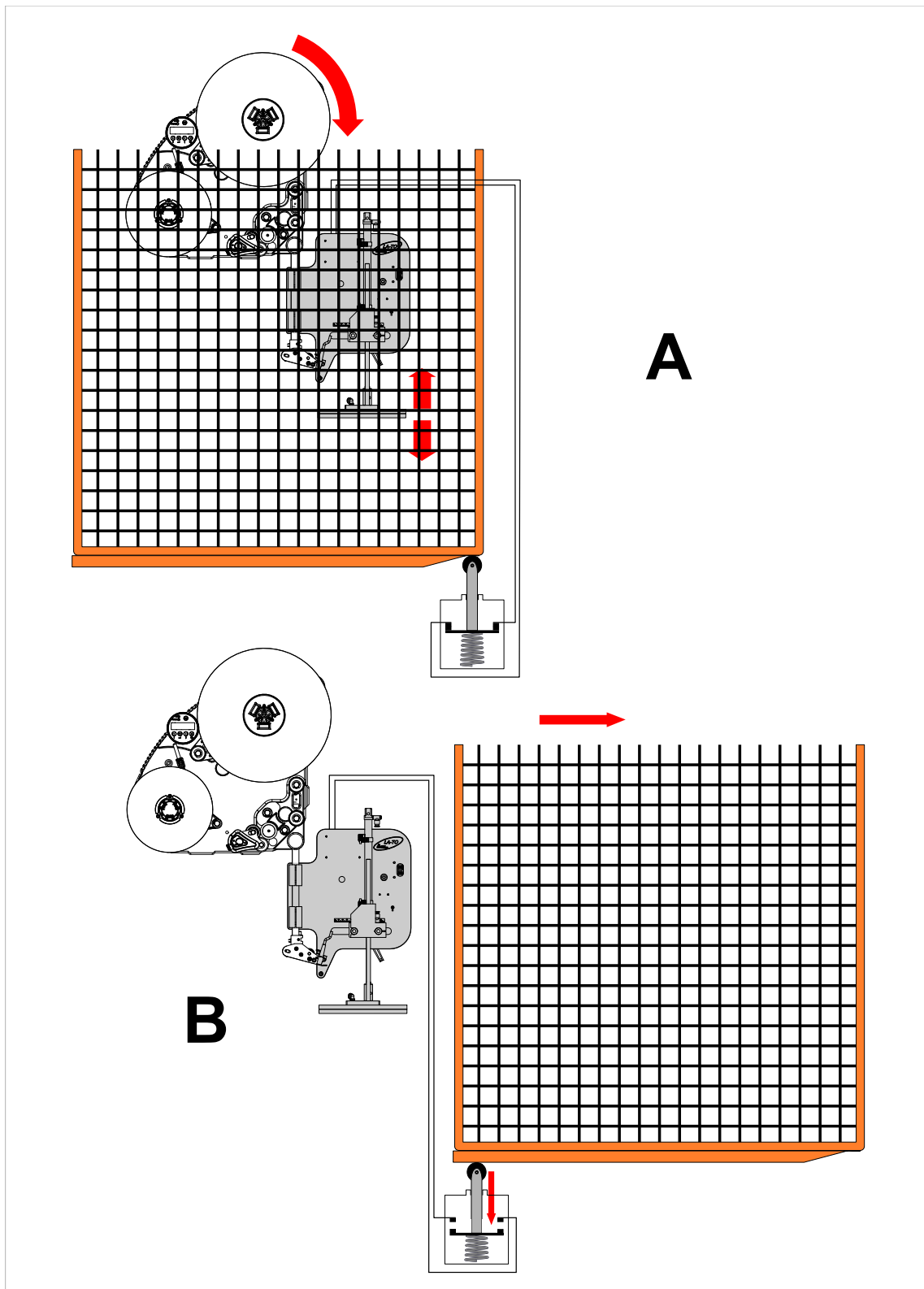

Fig. 3: Diagram of a movable interlocking guard (**A**: Protective guard closed. Interlock switch connected (C). Applicator is working; **B**: Protective guard open. Interlock switch not connected (D). Applicator stopped).

Emergency Stop

An external Emergency Stop device must be installed by the system integrator. It could be an Emergency Stop button located outside of the protective equipment, for example. The button must be pressed if a hazardous situation occurs or in the event of an emergency.

The external Emergency Stop device is not included in the scope of delivery of the machine.

Checking the safety functions

The following safety functions can be checked by the user or a service technician:

Safety function	Functional check
Emergency Stop	▶ Activate the Emergency Stop device (for example press the Emergency Stop button). The applicator must stop immediately.
Protective equipment	▶ Interrupt the safety switch circuit (for example open the safety door). The applicator must stop immediately.
Switching-on valve	▶ Switch on compressed air. The applicator foot moves from the end position slowly up to the home position. If the movement occurs abruptly, the switching-on valve must be adjusted by a service technician.

Table 2: Overview: Checking the safety functions

Operating safety of the machine

Installation, maintenance

**WARNING!**

Improper usage of the machine can lead to accidents, material damage and loss of production!

- ▶ When installing the machine, check for visible shipment damage. Immediately inform NOVEXX Solutions of any damage.
- ▶ When installing the machine, consider the admissible ambient conditions.
- ▶ When installing the machine, make sure that it can not tip over.
- ▶ When installing the machine, provide a supply disconnecting device and an emergency stop device.
- ▶ Install the supply disconnecting device and the emergency stop device in a way that they are easy reachable.
- ▶ Lay the connection cable and pneumatic hoses so that no one can trip over them.
- ▶ Check if all safety functions are functioning properly.
- ▶ Only put the machine into operation if it is in flawless condition.
- ▶ Only perform alterations or conversions to the machine with the consent of NOVEXX Solutions' customer service.
- ▶ Max. admissible operating air pressure: 6 bar
- ▶ Only link the applicator to devices that fulfil the ES1 circuit requirements specified in EN 62368-1.
- ▶ Fasten the pneumatic hoses in place to prevent them from whipping.
- ▶ Replace faulty pneumatic hoses immediately.
- ▶ Only put the machine into operation after at least one successful test run has been completed.
- ▶ Only use original replacement parts.

**WARNING!**

Danger of crushing between applicator and dispensing edge as well as between applicator and conveyor!

- ▶ Avoid access to the running machine by installing higher-level protective guards.

Warning of injuries due to electrical shock

**WARNING!**

The machine to which the applicator is attached works with mains voltage! Contacting electrically live components can cause lethal electrical shocks and burns.

- ▶ Switch the machine off before cleaning and servicing.
- ▶ Keep the machine dry.
- ▶ If a liquid gets into the machine, switch off the machine immediately. Notify a service technician.
- ▶ Only link the applicator to devices that fulfil the ES1 circuit requirements specified in EN 62368-1.
- ▶ In case of emergency switch off the machine.

Warning of injury hazards from mechanical components



WARNING!

Danger of crushing between the machine and conveyor equipment and between movable parts of the applicator!

- ▶ The machine may only be operated with higher-level protective equipment.
- ▶ Never remove or bypass the protective equipment that is designed to prevent reaching in while the machine is in operation.



WARNING!

Danger of injury due to moving and rapidly rotating parts!

- ▶ Maintain a safety clearance from the machine when it is in operation.
- ▶ Never reach into a machine that is running.
- ▶ Switch off the machine before making any mechanical adjustments.
- ▶ Keep clear of the area around moving parts even when the machine is stopped if there is any possibility of the machine starting up.



WARNING!

Entanglement hazard!

- ▶ When working in the vicinity of machines in operation, do not wear ties, loose clothing items, jewellery, wrist watches or similar objects on your body.
- ▶ Long hair must be kept in a hair net and must not be worn loose.



WARNING!

Tripping hazard!

- ▶ Lay the connection cable and pneumatic hoses (if fitted) so that no one can trip over them.

Warning notes on LA-TO

CAUTION!

Warning notes on the machine provide important information for the operating personnel.

- ▶ Do not remove warning notes.
- ▶ Replace missing or illegible warning notes.

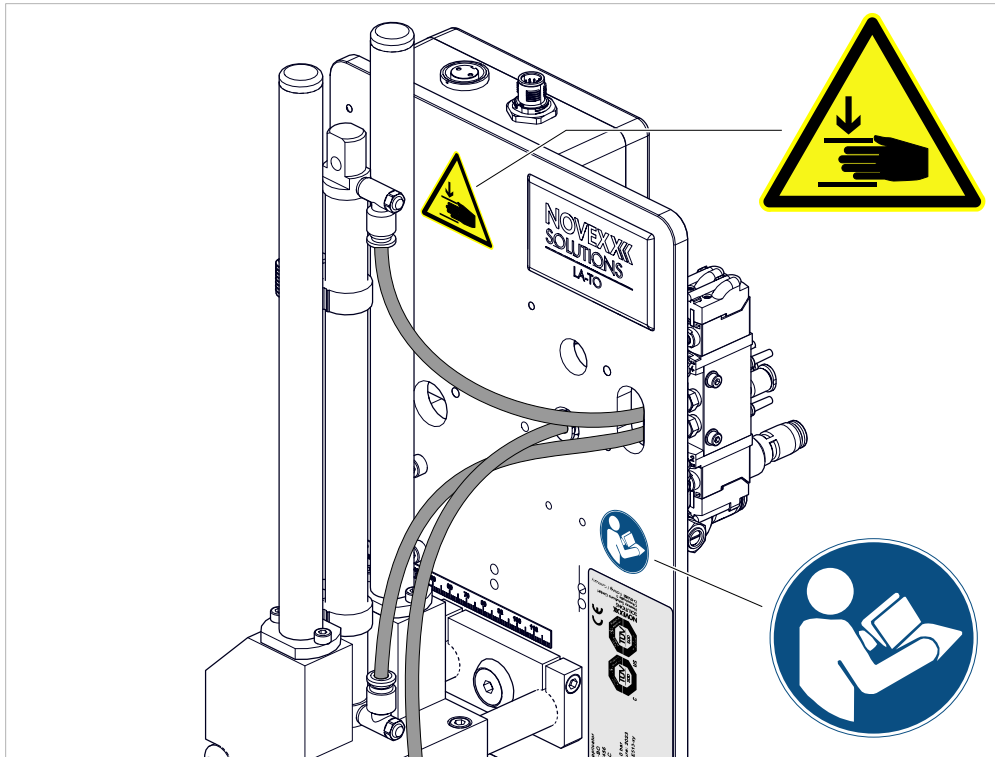



Fig. 4: Warning note on the LA-TO.

Warning note	Meaning	Article no.
	The warning symbol “Danger of crushing” warns of dangerous movements of the device that could lead to crushing. Switch off the device previously.	A103530
	The blue label “Read manual” demands that operators read the user manual.	A5331

Product description

TECHNICAL DATA

Differences between LA-TO and LA-TO XL

The table shows *those* properties that are different between LA-TO and LA-TO XL:

Specification	LA-TO	LA-TO XL
Stroke length	180 mm	380 mm
Product speed during application	15 m/min	keine
Air consumption per stroke	0.3 l	0.6 l
Size	See chapter "Dimensions" below	
Weight	approx. 5 kg	approx. 6 kg

Connectors

Power supply	<ul style="list-style-type: none"> • XLS 2xx: via <ul style="list-style-type: none"> – Standard signal interface or – Applicator interface (option) • XPA 93x: via 8IO interface (option)
Supply current	max. 0.5 A
Supply voltage	24 V(DC)
Supply air pressure	6 bar ^[1]
Air consumption	<ul style="list-style-type: none"> • LA-TO: 0.3 l/stroke • LA-TO XL: 0.6 l/stroke <p>Max. 40 l/min for vacuum (depending on duration of vacuum)</p>

Label material

Type	Self-adhesive (paper, plastic materials) ^[2]
Material width	<ul style="list-style-type: none"> • LA-TO (XL): 30-160 mm • LA-TO BO (XL): 50-110 mm
Material length	<ul style="list-style-type: none"> • LA-TO (XL): 30-210 mm • LA-TO BO (XL): 50-160 mm

¹ Max. admissible input pressure at the pressure regulator: 10 bar

² As a result of static charge and friction effects, plastic materials may tend to crease during the dispensation step. Therefore, plastic materials must be tested under application conditions before being used in production.

Application

Stroke length	<ul style="list-style-type: none"> • LA-TO: max. 180 mm • LA-TO XL: max. 380 mm <p>Usable distance, with sensors for end and home position LA-TO BO: Additionally to the max. stroke length, some centimeters^[3] blow-on length are added</p>
Application direction	From top, sideways or from bottom
Tolerance for label position	<ul style="list-style-type: none"> • LA-TO: ±1 mm • LA-TO BO: ±10 mm
Application angle	90°
Application pressure LA-TO TD	<ul style="list-style-type: none"> • At an edge of the touchdown plate: 16 -20N • In the middle of the touchdown plate: 30-35N
Product speed during application step	<ul style="list-style-type: none"> • LA-TO: max. 15 m/min • LA-TO XL: 0 m/min • LA-TO BO: max. 20 m/min
Air stream	Suction nozzle

Ambient conditions

Installation location	<ul style="list-style-type: none"> • Inside buildings • Protected from wind and spray water • Dry • Non-explosive atmosphere • Operation to max. 2000m above sea level
Operating temperature	5-40°C
Storage temperature	0-70°C
Air humidity	45-75% non-condensing
Noise emission	<70 dB(A)
Protection rating	IP 21

Dimensions

Size (B x H x T)	<ul style="list-style-type: none"> • LA-TO <ul style="list-style-type: none"> – for XLS 2xx: 275 x 442 x 295mm – for XPA 93x: 252 x 442 x 235mm • LA-TO XL <ul style="list-style-type: none"> – for XLS 2xx: 275 x 649 x 295mm – for XPA 93x: 252 x 649 x 235mm
Weight	<ul style="list-style-type: none"> • LA-TO: ca. 5 kg • LA-TO XL: ca. 6.5 kg

³ The blow-on length depends on several factors, e.g. label size and air pressure

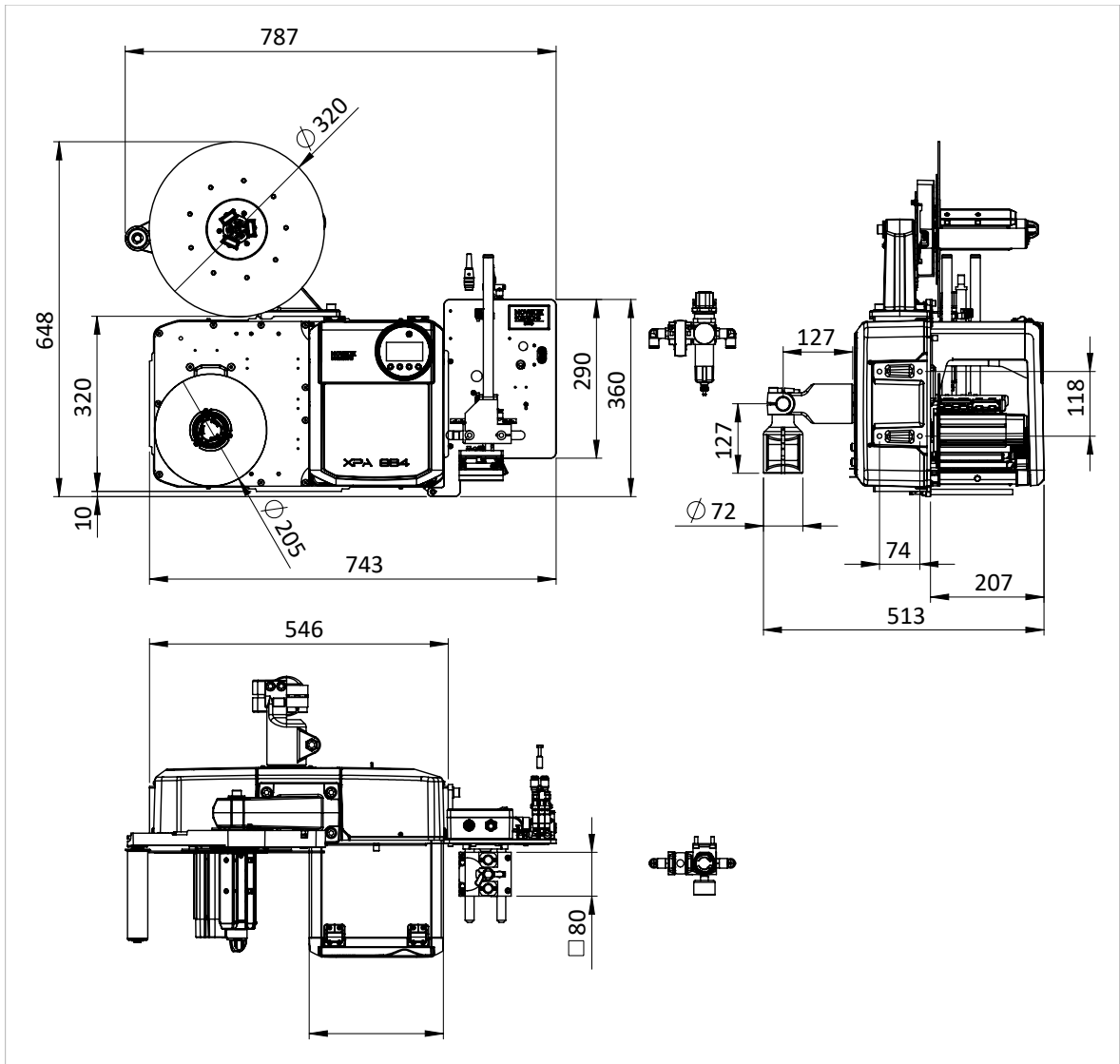

Fig. 5: Dimensions of the LA-TO TD at XPA 93x RH.

OVERVIEW

Product name

LA-TO is the abbreviation for “Label Applicator Touch-On”. The abbreviation “TO” (touch on) distinguishes this applicator from other application techniques such as “blow on” or “swing on”.

The designation LA-TO may be followed by one or two pairs of letters to define the applicator configuration in detail:

LA-TO xx yy

- xx = TD or BO
- yy = XL

Meaning of the letter pairs:

- **TD:** LA-TO with touch down sensor (TD = touch down). The applicator returns as soon as the applicator plate encounters resistance. Thus, products with alternating heights can be labelled.
- **BO:** LA-TO with blow-on function (BO = blow on). The last part of stroke length is overcome by blowing the label onto the product.
- **XL:** LA-TO with extended stroke length (XL = extended length).

List of LA-TO configurations:

- LA-TO
- LA-TO XL
- LA-TO TD
- LA-TO TD XL
- LA-TO BO
- LA-TO BO XL

For reasons of clarity in this manual, the XL, TD and BO designs are only mentioned separately, if their specifications or their use differ from the “standard” LA-TO.

For details refer to chapter Configurations ???.

“Machine” means in the following the labeler/print- & apply system with installed LA-TO applicator.

System requirements

Products

- LA-TO: admissible are
 - non-moving products with *alternating heights*
 - moving products with the *same height*
- LA-TO TD / LA-TO BO: Admissible are non-moving or moving products with *alternating heights*

Compressed air

- Compressed air connection must be available
- Mounting surface for pressure controller (see ???).

Machine (labeler / print & apply system)

Machine	Equipment
XPA 93x	Standard dispensing edge and optional 8IO board
XLS 2xx	<ul style="list-style-type: none"> • XLS 204, XLS 206, XLS 272 or XLS 256 with fixed L-shaped dispensing edge. • Control via the standard signal interface or via the optional applicator interface.

Firmware

Machine	Applicator	Machine firmware (min.)	AI firmware (min.)
XPA 93x	all LA-TO types	1.00	--

Machine	Applicator	Machine firmware (min.)	AI firmware (min.)
XLS 2xx	LA-TO, LA-TO TD	2.50	1.38
	LA-TO BO	2.52	1.40

Table 3: Firmware requirements for applicator operation.

Configurations

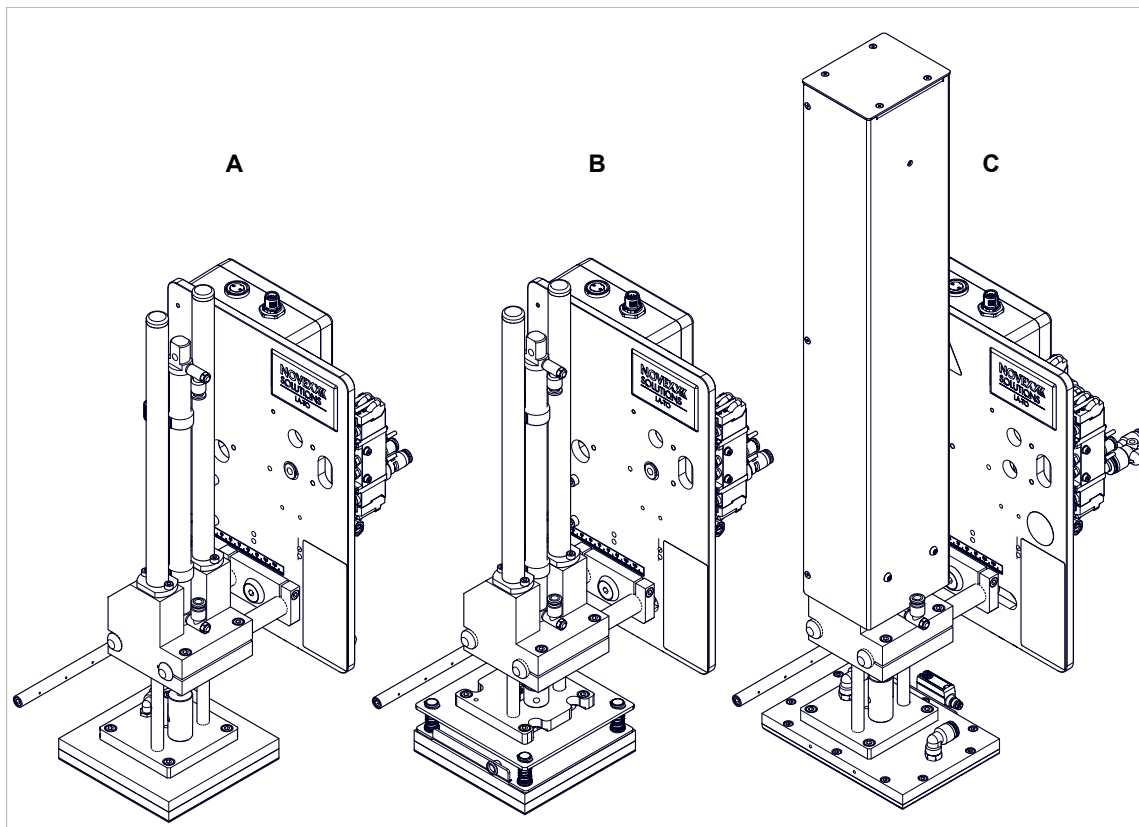

Fig. 6: Examples of LA-TO designs (all RH and all for XPA 93x; pictured without cables and hoses):

A	LA-TO (pad size 125x125 mm)
B	LA-TO TD (pad size 125x125 mm)
C	LA-TO BO XL (pad size 110x160 mm)

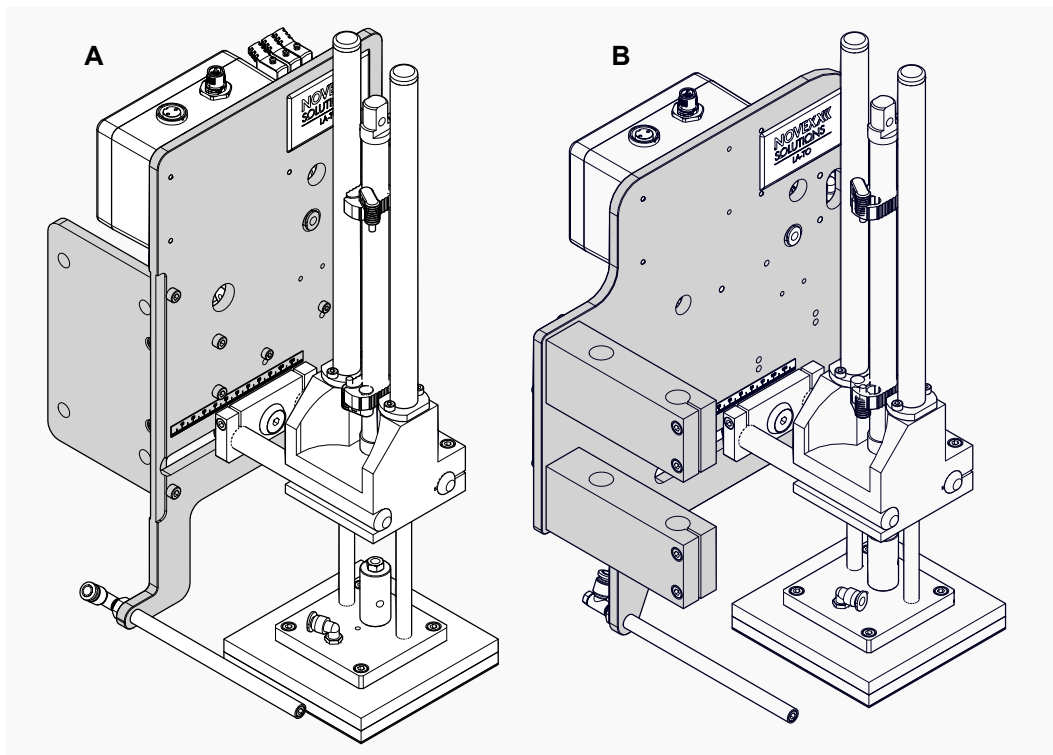

Fig. 7: LA-TO for XPA 93x(A) and for XLS 2xx (B) (picture without cables and hoses).

All LA-TO applicators are available in two designs, each right-handed or left-handed:

- XPA 93x: For fitting on one of the flanges on the machine frame (fig. above, A)
- XLS 2xx: For fitting on the dispensing edge holder for L-shape dispensing edges (fig. above, B)

|| Applicator and labeler / print- & apply system must be of the same handedness, that is both must be ||
RH or LH versions.

Functionality

 [Video showing an example application.](#)

The LA-TO applicator is an additional module to be mounted to one of the above named labelers or print & apply machines (see chapter **Intended use** on page 6). The device takes over self-adhesive labels from the dispensing edge of the labeler / print & apply system, moves each of the labels to the product in a linear movement and presses or blows (LA-TO BO) it to the product.

The label is sucked on to the pressure plate that is driven by a pneumatic cylinder between home position and end position. With the LA-TO BO, the label is blown from the pressure plate onto the product.

In home position, the label is taken over from the labeler or the print & apply machine. The arrival of the pressure plate in home position is detected by a sensor at the pneumatic cylinder of the applicator. The label is peeled off the backing paper by the dispensing edge and is pushed under the pressure plate, where it is sucked on by a vacuum. Additionally, the label is blown onto the pressure plate by an air stream from the support air nozzle. Afterwards, the pressure plate moves to the end position. In this position, the label is pressed or blown onto the product (LA-TO BO).

The arrival in the end position is either detected by a sensor ^[4] (sensor controlled), or by reaching the end of a time interval set in the parameter menu (time controlled) (see chapter **Parameter settings** on page 39).

Component overview

LA-TO front side

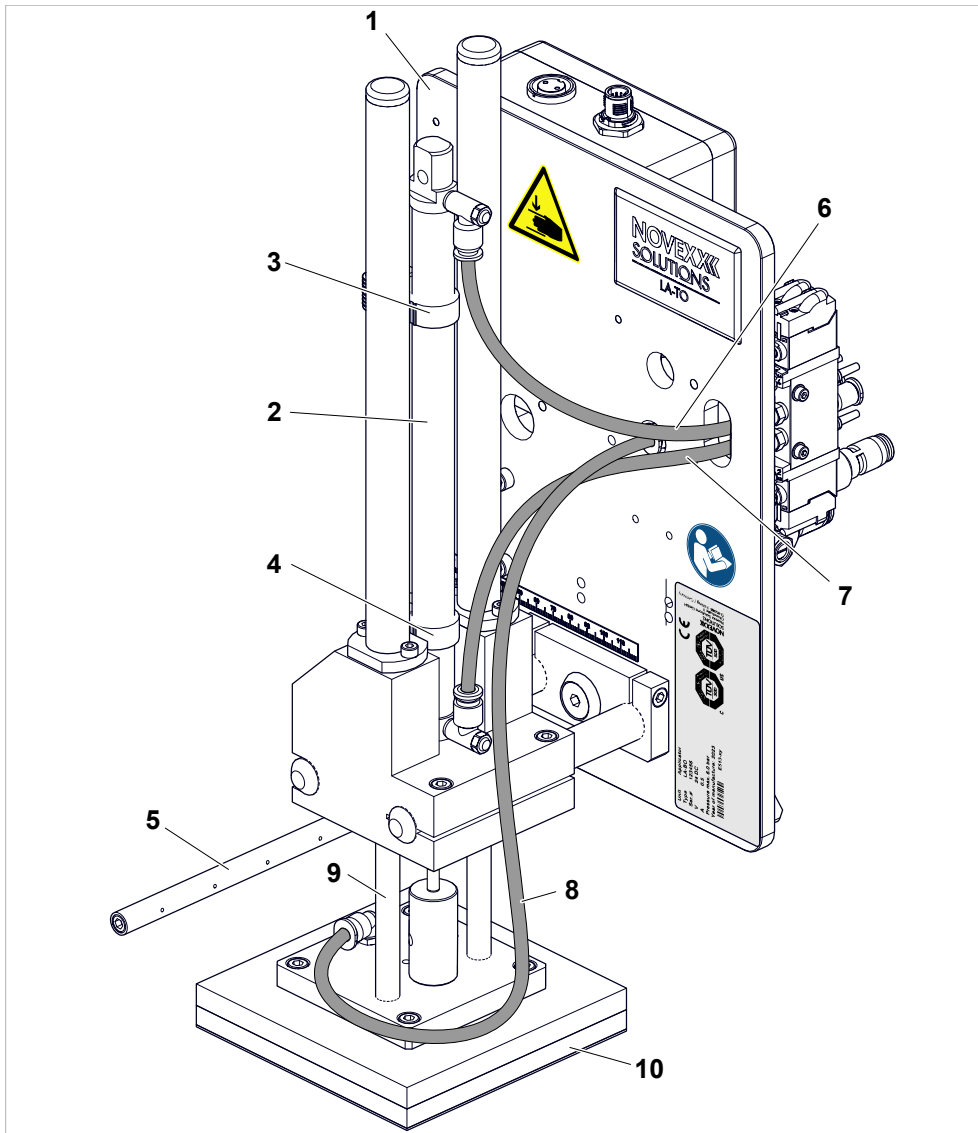

Fig. 8: Front side(LA-TO for XPA 93x RH).

No.	Name
1	Mounting plate (type-specific)
2	Pneumatic cylinder
3	Home position sensor

⁴ End position sensor at LA-TO or touchdown sensor at LA-TO TD

No.	Name
4	End position sensor (not at LA-TO BO)
5	Support air nozzle
6	Pressure line for downwards movement
7	Pressure line for upwards movement
8	Vacuum line for vacuum plate
9	Guide rod
10	Vacuum plate (LA-TO TD: touchdown plate)

LA-TO rear side

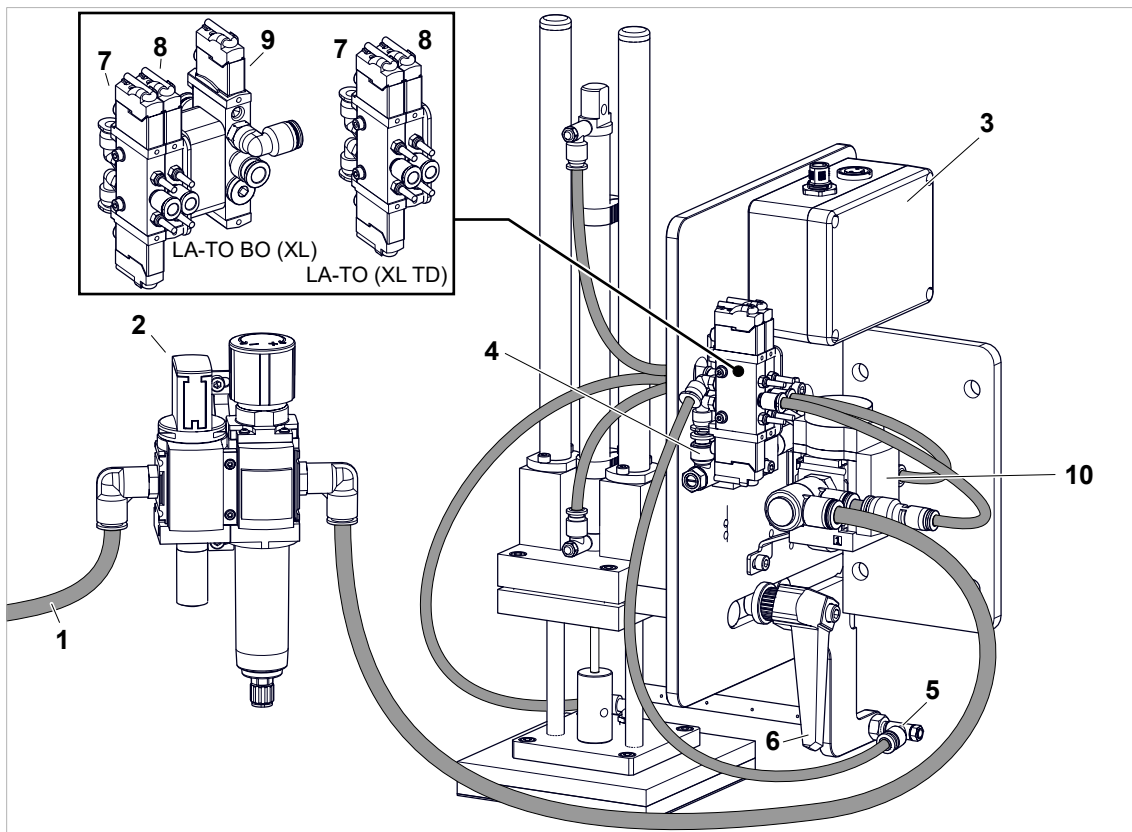

Fig. 9: Rear side (LA-TO for XPA 93x RH).

No.	Name
1	Compressed air connector (10 mm tube-Ø)
2	Service unit (manual on-off valve, filter regulator, condensate drain)
3	Connector box (type-specific)
4	Support air valve with silencer
5	Connector and setting valve support air nozzle
6	Clamping lever

No.	Name
7	Support air nozzle
8	Cylinder and vacuum valve
9	(LA-TO BO) Blow-on valve
10	On-off valve

PARAMETERS

(XPA 93x) Applicator-parameters in the parameter menu

The parameters for controlling the applicator appear in a separate submenu under **Options > 8IO 1 > LA-TO** . The prerequisite is that the optional 8IO board is present and that the applicator is activated (see below).

Activating LA-TO ^[5]:

► **Options > Selection > 8IO 1 > Applicator > Applicator type = “LA-TO”** ^[5]

The submenu for LA-TO ^[5] then appears:

Options						
L	8IO 1					
	L	LA-TO ^[5]	LA-TO	LA-TO TD	LA-TO BO Timed	LA-TO BO Sensor
	┆	Apply mode	X	X	X	X
	┆	TouchDownTimeout		X		X
	┆	Dwell time	X		X	
	┆	Blow on time			X	X
	┆	Position timeout	X	X	X	X
	┆	Restart delay	X	X	X	X
	┆	Apply comp. time	X	X	X	X
	L	Label pres. sensor	X	X	X	X

Table 4: Structure of the parameter menu. The parameters marked with a check mark are available for the corresponding applicator type.

(XLS 2xx) Applicator-parameters in the parameter menu

The parameters for controlling the applicator appear in a separate submenu under **SIGNAL INTERFACE > Applic. signals** (standard) or under **SIGNAL INTERFACE > >AI BOARD SIGNAL (AI)**, depending on the configuration of the interface. This requires the following:

Standard:

- The interface is configured for applicator operation:

⁵ or LA-TO TD or “LA-TO BO Timed” or “LA-TO BO Sensor”

SIGNAL INTERFACE > Interface mode = “Applic. signals”

- The correct applicator type is activated:

SIGNAL INTERFACE > Applic. signals > Applicator type = “LA-TO” ^[6]

AI:

- The optional AI board is available
- The correct applicator type is activated:

SIGNAL INTERFACE > >AI BOARD SIGNAL > Applicator type = “LA-TO” ^[6]

SIGNAL INTERFACE						
L	Applic. signals (Standard) >AI BOARD SIGNAL (AI)					
	┆ Applicator type	LA-TO	LA-TO TD	LA-TO BO Timed	LA-TO BO Sensor	
	┆ Apply mode	X	X	X	X	
	┆ Applizierzeit	X		X		
	┆ Blow on time			X	X	
	┆ Restart delay	X	X	X	X	
	┆ Position timeout	X	X	X	X	
	┆ Apply comp. time	X	X	X	X	
	┆ TouchDownTimeout		X		X	
	L Touch down sens.		X		X	

Table 5: Structure of the parameter menu. The parameters marked with a check mark are available for the corresponding applicator type.

⁶ or LA-TO TD or “LA-TO BO Timed” or “LA-TO BO Sensor”

Parameter Reference (Applicators)

Apply mode(Print & Apply Systems)

Setting range	Default setting	Step size	Easy Plug
After start sig., After print, After custom start sig.	After start sig.	--	#PC3102

Defines, if the application process starts with applying (“After start sig.”) or with printing (“After print”). Requirements: Printjob transferred, machine is ready for operation.

- *After start sig.*: The start signal triggers the application of an already printed and dispensed label. After applying the label, the next one is immediately printed and dispensed.
- *After print*: The start signal triggers the retraction under the print head, printing, dispensing and application of a label.
- *After custom start sig.*: Enables the application process to be controlled via XApps.

Apply mode (Labelers)

Setting range	Default setting	Step size	Easy Plug
After start sig., After dispensing	After start sig.	--	--

Defines, if the application process starts with applying (“After start sig.”) or with dispensing (“After dispensing”).

- *After start sig.*: The start signal triggers the application of an already dispensed label. After applying the label, the next one is immediately dispensed.
- *After dispensing*: The start signal triggers dispensing and application of a label.

TouchDownTimeout

|| Only at applicators that work with a touchdown sensor: LA-TO TD, LA-TO BO Sensor, LTP/LTPV ||

Setting range	Default setting	Step size	Easy Plug
Off, (100...99999) ms	Off	--	#PC3117

Timeout at the touchdown sensor. This time specifies the maximum wait time for the touchdown trigger event.

- *Off*: The timeout function is switched off. The applicator only moves back when the touchdown event has taken place. If the event does not take place (no TD signal), it waits indefinitely..
- *xxxx ms*: If the specified time xxxx ms is exceeded without the touchdown event, the applicator continues operation in the same manner as the touchdown event would have taken place. No error message will appear in this case.

Touch down sens.

|| Only sensor-controlled applicators: LA-TO TD, LA-TO BO Sensor, LTP/LTPV ||

Setting range	Default setting	Step size	Easy Plug
Pulse falling, Pulse rising	Pulse falling	--	--

Determines the switching behavior of the touchdown sensor.

- *Pulse falling*: The *falling* signal edge at the sensor triggers the touchdown event.
- *Pulse rising*: The *rising* signal edge at the sensor triggers the touchdown event.

Dwell time

|| Only time-controlled applicators: LA-TO, LA-TO BO Timed, LA-SO ||

Setting range	Default setting	Step size	Easy Plug
[1..99999] ms	500 ms (LA-TO, LA-TO BO)	1 ms	#PC3106

Determines the time period, during which the applicator is extended.

Is required for time-controlled applicators that are not limited by a touch-down signal.

Blow on time

|| Only applicators with blow-on function: LA-TO BO ||

Setting range	Default setting	Step size	Easy Plug
[0...99999] ms	50 ms (LA-TO BO)	1 ms	#PC3107

Sets the blow-on duration.

Position timeout(Print & Apply Systems)

Setting range	Default setting	Step size	Easy Plug
Off, (500...99999) ms	2000 ms	1 ms	#PC3109

- *Off*: The timeout function is switched off. Compressed air is applied to the applicator until the home or end position signal is received. If no signal is received, the applicator continues to try to reach the respective end position. No error message is displayed.
- *xxxx ms*: Determines the length of time after which an applicator position error is displayed as an error. A position error is considered to have occurred if the applicator has failed to reach the home or the end position within the set timeframe.

Corresponding error messages:

```
Status num: 5200
Home position
```

```
Status num: 5201
End position
```

Position timeout (Labeler)

Setting range	Default setting	Step size	Easy Plug
(500...99999) ms	2000 ms	1 ms	--

xxxx ms: Determines the length of time after which an applicator position error is displayed as an error. A position error is considered to have occurred if the applicator has failed to reach the home or the end position within the set timeframe.

Corresponding error messages:

```
Status num: 5200
Home position
```

```
Status num: 5201
End position
```

Restart delay

Setting range	Default setting	Step size	Easy Plug
[0...99999] ms	0 ms	1 ms	#PC3108

Determines the length of time after application for which no start signals will be accepted.

Apply comp. time

Setting range	Default setting	Step size	Easy Plug
[0...99999] ms	0 ms	1 ms	#PC3111

Compensation time for applicator stroke time; required for variable conveyor speed operation.

Most applicators have a constant stroke time. If the labeller or the print & apply system is driven with variable speed, this leads to different label positions on the product. With a slow conveyor speed, the touch down comes too early, with a high conveyor speed, it is too late. With the stroke time entered in the *Apply comp. time* parameter, the system corrects this effect, and therefore improves the labelling precision.

Setting instruction:

- ▶ Setup the (print-)dispense-apply-process with a slow conveyor speed.
- ▶ Turn the conveyor speed high.
- ▶ Adjust the labelling position by increasing the *Apply comp. time* step by step, until the labelling position is correct.

Label pres. sensor

Setting range	Default setting	Step size	Easy Plug
Off, On	Off	--	#PC3119

Activates the “label-present sensor” if the applicator has one. The sensor checks whether a label is present on the applicator. Depending on the design, this can be done before or after application. Depending on the design, it is evaluated as an error if no label is present before application, or if a label is still present on the applicator after application:

```
Status num: 5215  
Label on appl
```

```
Status num: 5216  
No label on appl
```

Startup

ASSEMBLY

**WARNING!**

Risk of tripping!

- ▶ Lay cables and compressed air hoses in a way that nobody can stumble over it.

**WARNING!**

Risk of injuries caused by lashing pneumatic hoses.

- ▶ Fix pneumatic hoses against lashing.
- ▶ Immediately replace defective pneumatic hoses.

Preparing the connection cable for the interlock circuit

The LA-TO comes with a plug that is intended for connecting an interlocking guard.

Before you begin

Tool

- Screwdriver small (0.6x3.5 mm)

Procedure

Connect the plug (fig.) to the interlock switch, which is part of the interlock circuit.

See chapter [Connecting an interlocking guard](#) on page 8.

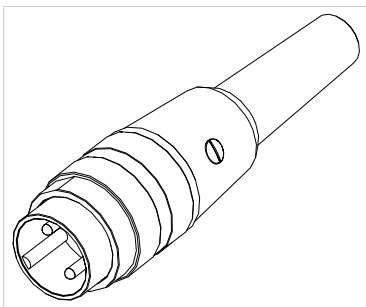

Mounting on XPA 93x

Before you begin

Tool: Hex socket screwdriver 8 mm

Procedure

1. Switch off the machine.

2. Screw the LA-TO to the flange (B) of the XPA 93x using the 4 screws (A) supplied:

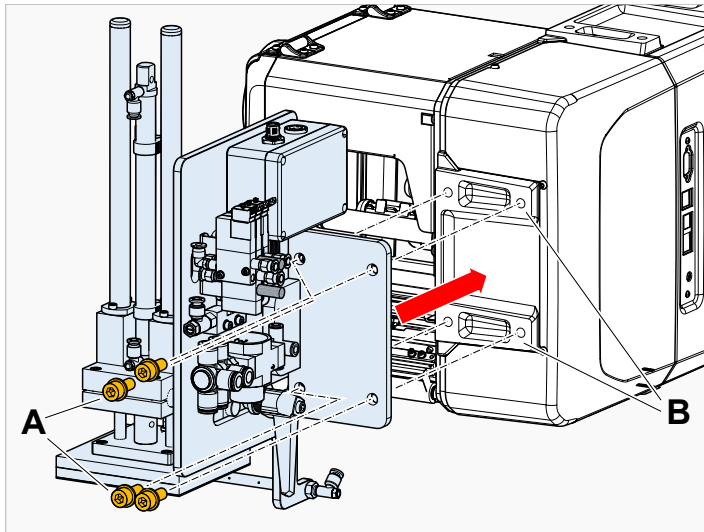

3. Connect the connecting cable to LA-TO and XPA 93x (A) (item no. N101573):

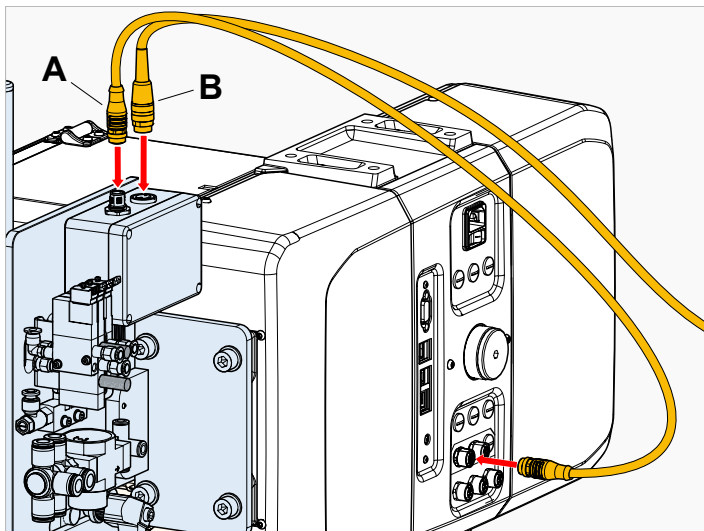

4. Connect the interlock switch of the protective guard to the LA-TO (fig. above, B). See **Connecting an interlocking guard** on page 8.

Connecting an interlock circuit is mandatory. The LA-TO must not and cannot be operated without.

5. Install the maintenance unit.
6. Connect the compressed air supply.
7. Turn on the machine.
8. Make settings in the parameter menu.
9. Adjust the LA-TO.

Related tasks

Installing the service unit on page 34

Connecting the compressed air on page 35

Related reference

(XPA 93x) Applicator-parameters in the parameter menu on page 22

Mounting on XLS 2xx

Before you begin

Tools: Hex socket screwdriver 4 / 6 mm

Procedure

1. Switch off the machine.
2. Mark the lateral position of the dispensing edge (material zero-line), before disassembling it.
3. Unscrew 1 screw (A) and take off the dispensing edge (B):

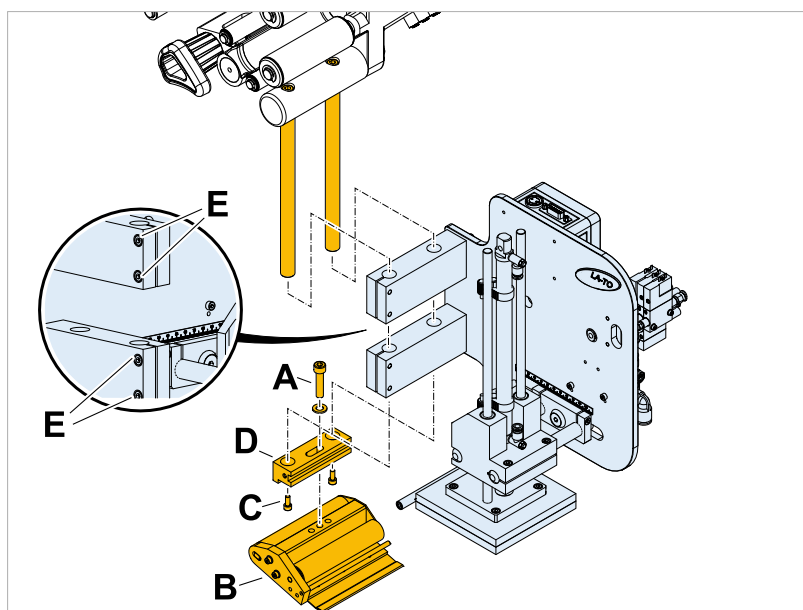

4. Unscrew 2 screws (fig. above, C) and remove the lower cross arm (fig. above, D).
5. Push the LA-TO onto the holding rods and fasten it there using the 4 locking screws (fig. above, E).
6. Reattach the dispensing edge in the previously marked position.

7. Connect the cable to LA-TO and machine.
 - Connection to standard signal interface (A) (article no.: N104045):

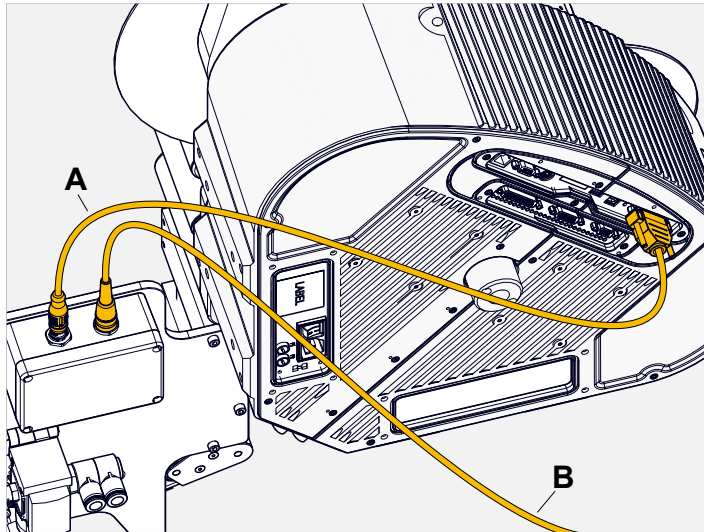

- Connection to applicator interface (A) (article no.: N104044):

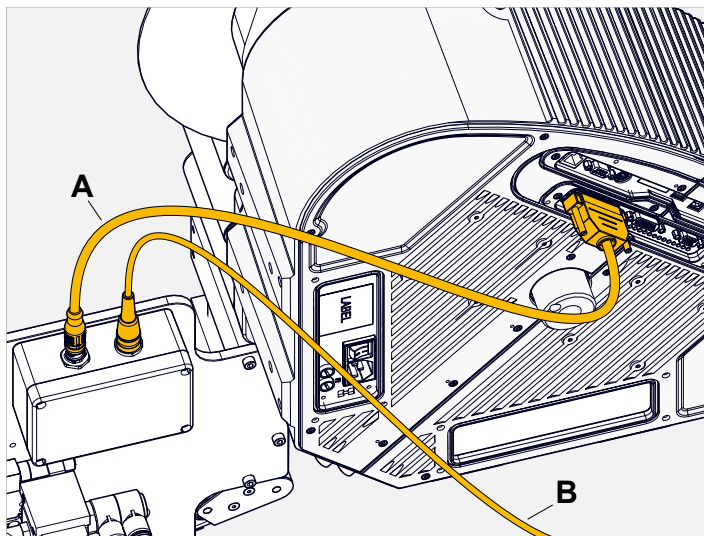

8. Connect the interlock switch of the protective guard to the LA-TO (fig. above, B). See **Connecting an interlocking guard** on page 8.

|| Connecting an interlock circuit is mandatory. The LA-TO must not and cannot be operated without. ||

9. Install the maintenance unit.
10. Connect the compressed air supply.
11. Turn on the machine.
12. Make settings in the parameter menu.
13. Adjust the LA-TO.

Related tasks

Installing the service unit on page 34

Connecting the compressed air on page 35

Related reference

(XLS 2xx) Applicator-parameters in the parameter menu on page 22

Installing the service unit

The service unit comes with the applicator. It consists of the following parts:

- Manual on-off valve (A)
- Filter regulator (B) with pressure gauge (C)
- Condensate drain (D)

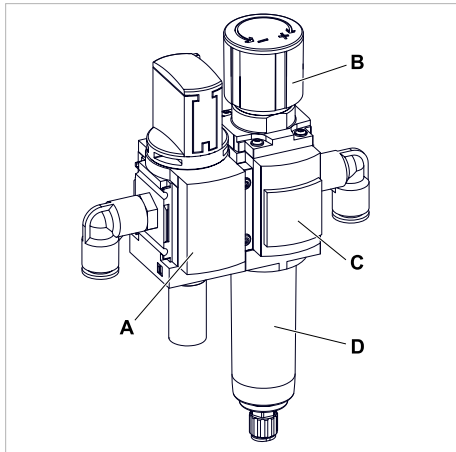

Fig. 10: Components of the maintenance unit.

Before you begin

Tool: 4 mm hex screwdriver

Procedure

1. Screw on the maintenance unit with the enclosed screws (M5x12).

|| The condensate drain (B) must point downwards. ||

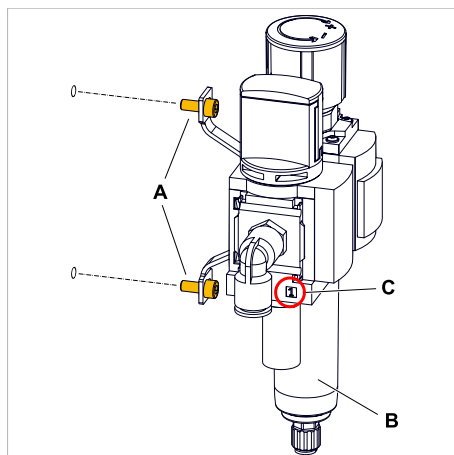

2. Fasten the pressure tubes so that the air flows through the pressure regulator in the direction from mark "1" (image above, C) to mark "2".

The connector marked "2" is the compressed air outlet. This must be connected to the applicator.

Mind the instruction sheet of the manufacturer, which comes with the service unit.

Connecting the compressed air

Before you begin

Prerequisites

- Hose diameter: 10 mm
- Maximum admissible compressed air pressure at the service unit *entrance*: 10 bar
- Maximum admissible compressed air pressure at the service unit *exit*: 6 bar

Procedure

1. Switch off the on-off valve. To do this, turn the rotary knob (A) clockwise as far as it will go:

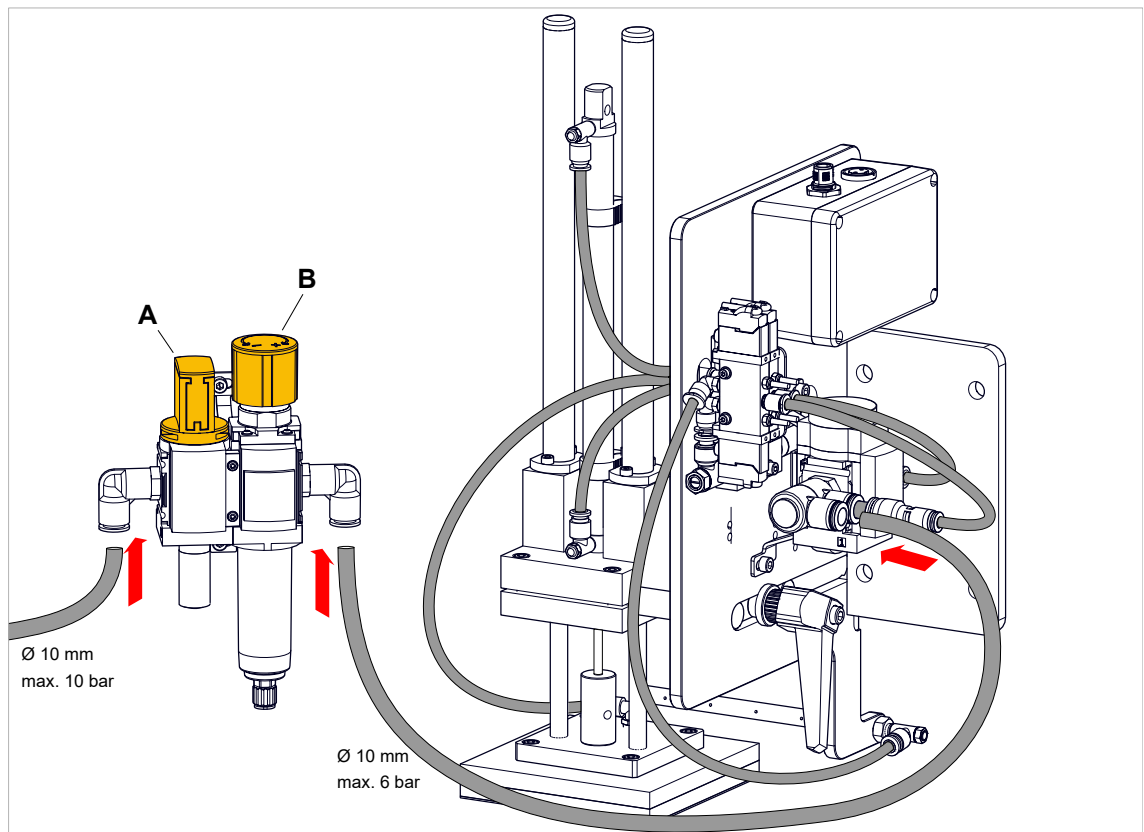

2. Reduce the outlet pressure completely. To do this, turn the control valve knob (fig. above, B) all the way to "-".
3. Connect the compressed air line to the connections as shown (fig. above).
4. Switch on the compressed air.

5. Switch on the on-off valve. To do this, turn the rotary knob (fig. above, A) counterclockwise as far as it will go.
6. Set the outlet pressure. To do this, slowly turn the control valve knob (fig. above, B) in the “+” direction until the pressure gauge indicates the desired outlet pressure.
|| Mind the instruction sheet of the manufacturer that comes with the service unit. ||

Connecting the compressed air (alternative way)

About this task

Alternatively, the vacuum and support air valves can be supplied with compressed air continuously. This has the advantage that a label already adhering to the applicator pressure plate remains there if the applicator's compressed air supply is shut off by an emergency stop.

CAUTION!

After switching off the compressed air supply, the applicator pressure plate moves to the end position. Hazard of damaging the applicator by collision with passing products.

- ▶ Stop the conveyor or
- ▶ Make sure that no products pass by or
- ▶ Fix the applicator pressure plate in its home position

Procedure

1. Disconnect hose (C) from the multiple distributor (A) and connect it to a permanently available support air supply.

|| Max. pressure: 6 bar

||

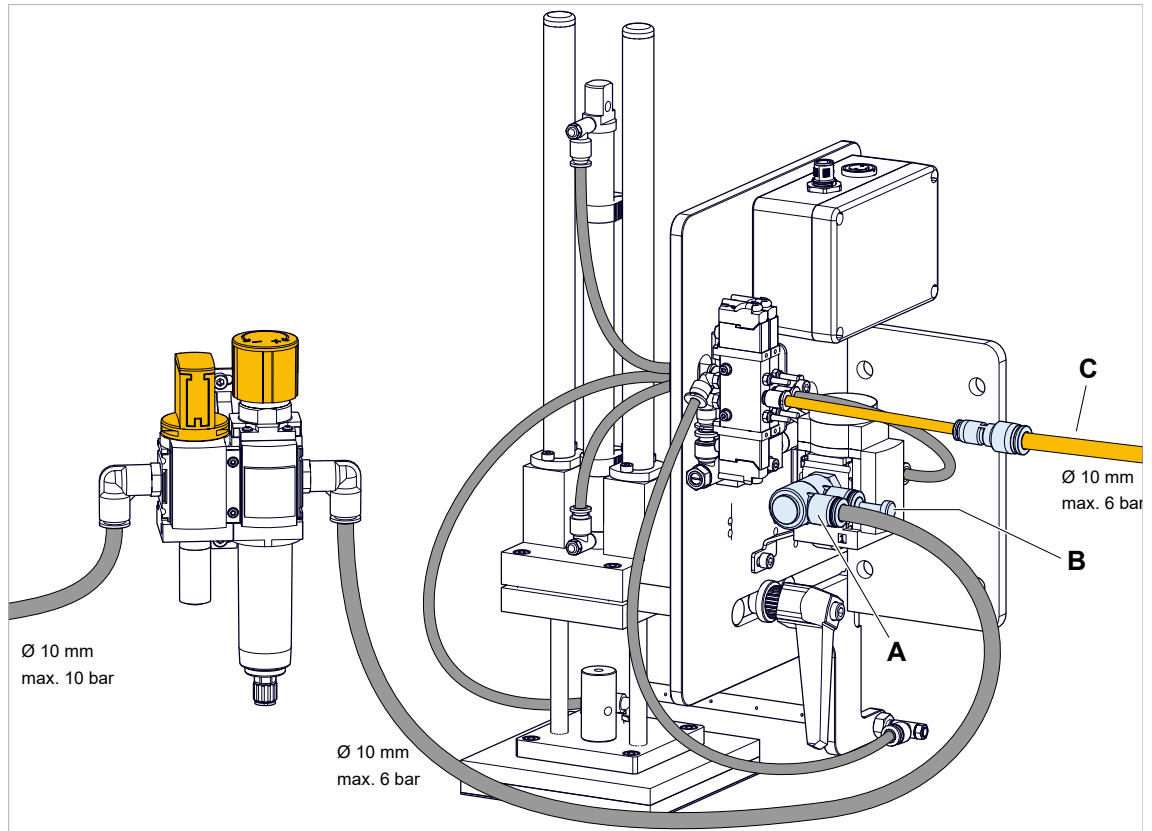

2. Close the now open fitting at the multiple distributor with the dummy plug (fig. above, B) that came with the applicator.

Selecting the size of the vacuum plate

The LA-TO(XL) and LA-TO TD (XL) can be equipped with vacuum plates in 4 sizes:

Andruckplatte (L x W)	Article no.
80 x 80 mm	A103966
125 x 125 mm	A103967
160 x 110 mm	A9415
210 x 160 mm ^[7]	A9410

With those vacuum plates, labels in the following size range can be applied:

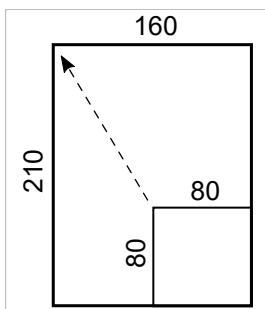

Fig. 11: Size range for labels: 80 x 80 mm to 160 x 210 mm (length x width)

Selecting the appropriate pad:

- Choose the *smallest possible* vacuum plate

|| The label must not be larger than the vacuum plate.

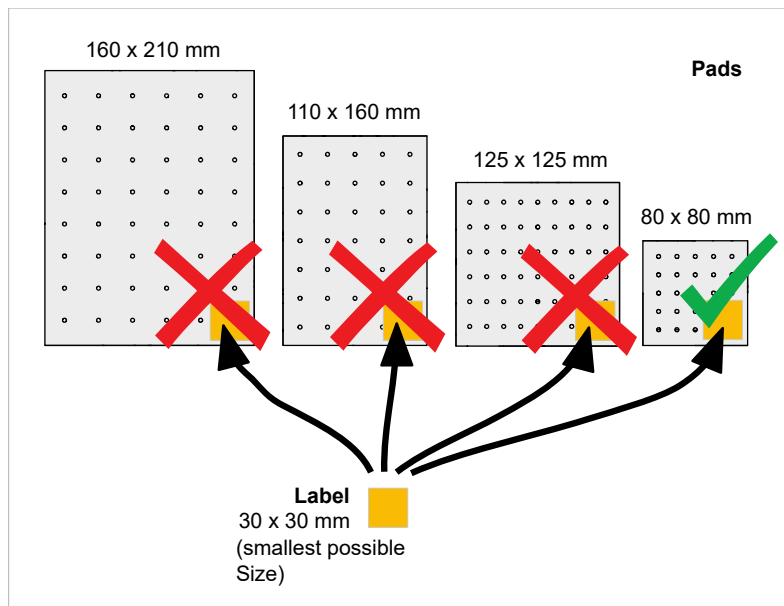

Fig. 12: Example: Selecting the vacuum plate for a 30 x 30 mm label.

⁷ Passend für DIN A5 Etiketten.

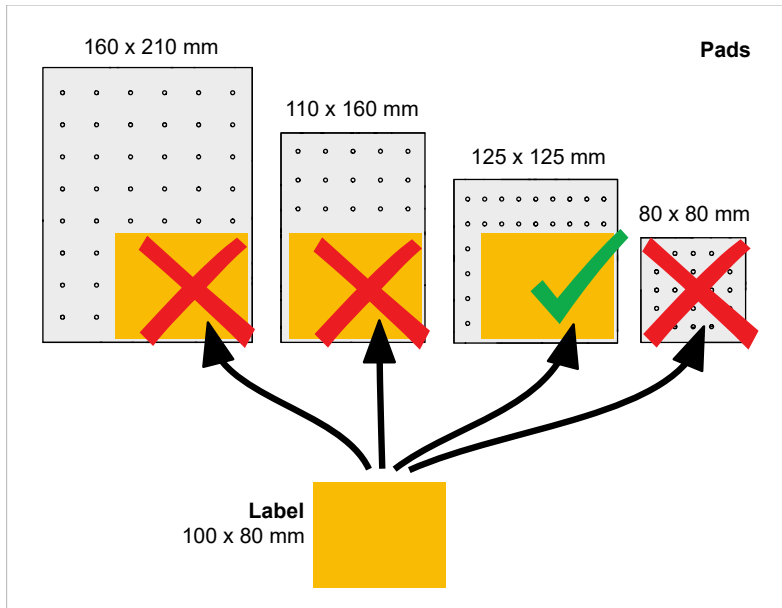

Fig. 13: Example: Selecting the vacuum plate for a 100 x 80 mm label.

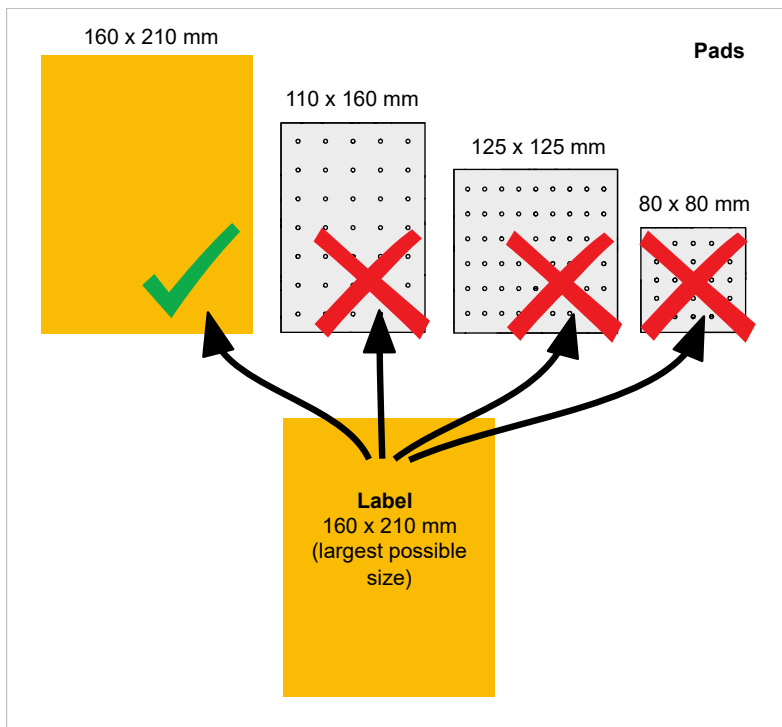

Fig. 14: Example: Selecting the vacuum plate for a 160 x 210 mm label.

PARAMETER SETTINGS

Activating the applicator

First, the applicator must be activated in the machine's parameter menu. The applicator type setting must correspond to the applicator that is attached.

Example: Activating LA-TO in the parameter menu of the XPA 93x:

- ▶ Options > Selection > 8IO 1 > Applicator > Applicator type = "LA-TO"

Setting the stroke length

Stroke length = Distance traveled by the pressure plate + blow-on distance with LA-TO BO

- *Time-controlled applicators* (LA-TO and "LA-TO BO Timed"):

- LA-TO

- ▶ Increase the dwell time value gradually until the applicator foot reaches the product and the label is pressed down lightly.

- LA-TO BO Timed

- ▶ Increase the dwell time value incrementally until the applicator foot stops at a suitable distance above the product so that the label can travel the rest of the way by air flow.
- ▶ Adjust the **Blow on time** so that the label is blown onto the product.

- *Sensor-controlled applicators* (LA-TO TD and "LA-TO BO Sensor"):

Here, the stroke is limited by a sensor.

- The LA-TO TD has a touchdown sensor that automatically detects when the product has been reached (no adjustment required).
- The "LA-TO BO Sensor" has a proximity sensor that stops the applicator foot at a preset distance above the product, pauses, and then blows the rest of the way.
 - ▶ Adjust the sensor (directly on the sensor) so that the applicator foot stops at the desired distance above the product.
 - ▶ Adjust the **Blow on time** so that the label is blown onto the product.

All other parameters can initially retain their default values. It is advisable to change these gradually later if necessary, once the basic function of the applicator has been established in the application.

Options							
L	8IO 1						
	L	LA-TO	LA-TO	LA-TO TD	LA-TO BO Timed	LA-TO BO Sensor	
			Apply mode	X	X	X	X
			TouchDownTimeout		X		X
			Dwell time	X		X	
			Blow on time			X	X
			Position timeout	X	X	X	X
			Restart delay	X	X	X	X
			Apply comp. time	X	X	X	X
	L		Label pres. sensor	X	X	X	X

Table 6: Structure of the parameter menu. The parameters marked with a check mark are available for the corresponding applicator type..

Related reference

(XPA 93x) [Applicator-parameters in the parameter menu](#) on page 22

(XLS 2xx) Applicator-parameters in the parameter menu on page 22

MECHANICAL ADJUSTMENTS



WARNING!

Risk of shear and crush injuries when testing the applicator in adjustment mode.

- ▶ keep a sufficient distance.
- ▶ do not touch the applicator.

Hazardous areas are:

- Between pressure plate and dispensing edge
- Between pressure plate and conveyor belt, if present

The following description only refers to the "LA-TO für XPA 93x" model. Only one model of pressure plate is shown.

All settings can be transferred to the "LA-TO für XLS 2xx" model and to all pressure plate sizes in the same way.

If the LA-TO is mounted on an XLS 2xx, the height offset can also be adjusted by loosening the clamping blocks of the LA-TO. After moving the LA-TO on the retaining rods, the clamping blocks must be fixed again.

Adjusting the lateral position of the pressure plate

Before you begin

Tool: Hex socket screwdriver 4 mm

About this task

The lateral position of the vacuum plate must be set so that labels can be pushed onto the centre of the vacuum plate. If this is not the case, the lateral position of the vacuum plate can be adjusted as follows:

Procedure

1. Unplug the compressed air line.

2. Remove the two Allen bolts (A):

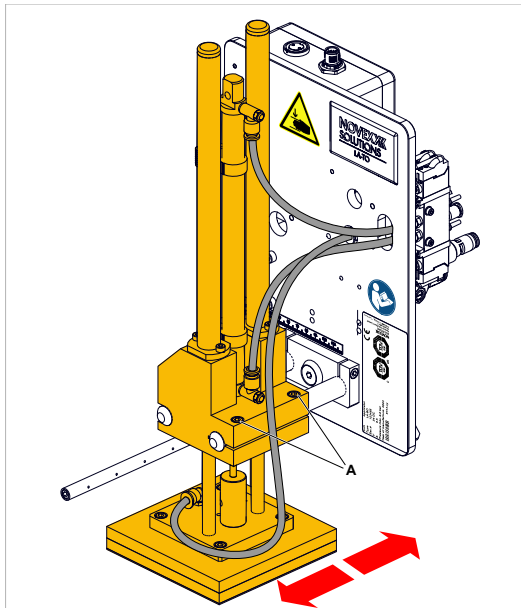

3. Push the vacuum plate so that the labels are transferred centrally.
4. Fasten the vacuum plate in place using the Allen bolts (A).

Adjusting the distance between pressure plate and dispensing edge

The gap between pressure plate and dispensing edge must be set so that the label passes around the edge of the pressure plate and pushes onto the plate as closely and smoothly as possible.

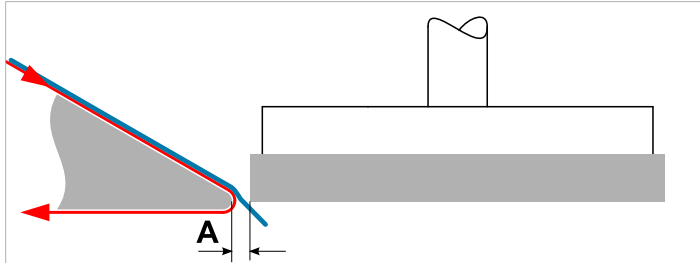

Fig. 15: Distance between dispensing edge and pressure plate (schematic).

The movement of the label onto the applicator pressure plate is influenced by the dispensing speed, the label characteristics and by the following settings:

- Horizontal gap between dispensing edge and pressure plate (fig. above, A)
- Vertical distance between dispensing edge and pressure plate
- Setting of the support air stream (see chapter „Checking the transfer process“ ???)

Before you begin

Tool: Spanner SW 10

Procedure

Setting the horizontal distance:

1. Unplug the compressed air line.
2. Loosen the clamping lever (A):

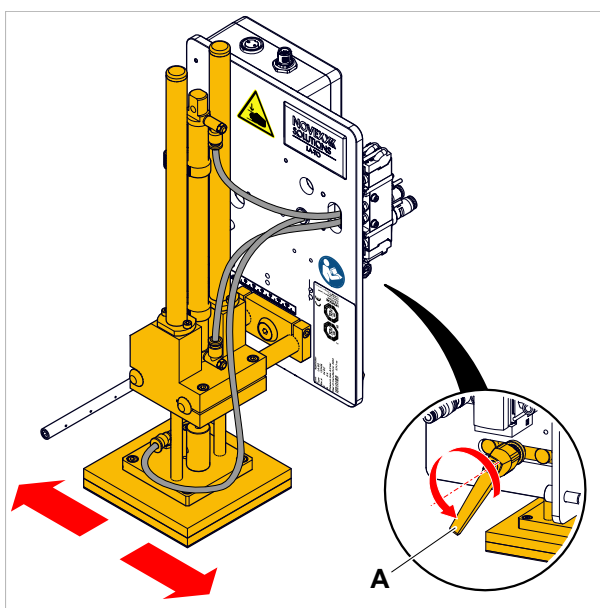

3. Push the transport unit until the vacuum plate is positioned approximately 3 mm behind the label dispensing edge.
4. Tighten the clamping lever.

Setting the vertical distance:

5. Unplug the compressed air line.
6. Loosen the counter nut (A):

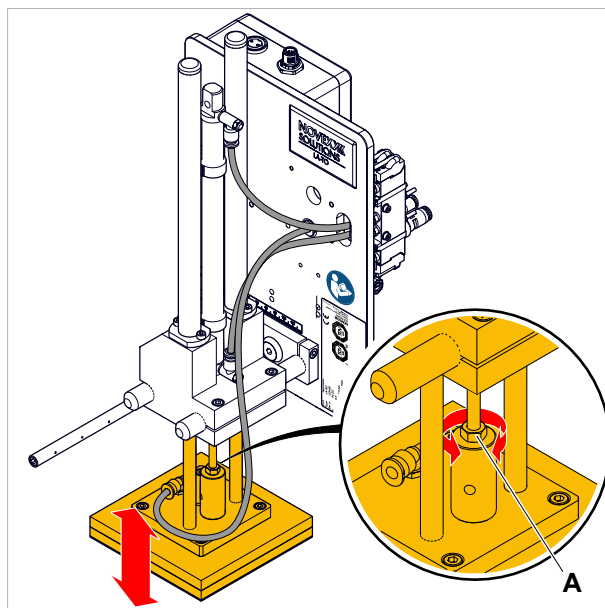

7. Depending on its current position, turn the piston rod clockwise or anti-clockwise.
|| Set the applicator position so that the dispensed label is pushed *just under* the applicator plate. ||
8. Change the position if necessary.
9. Retighten the counter nut.

Operation

ACTIVATING/DEACTIVATING THE APPLICATOR

Activating

In *normal operation* mode, the applicator is supplied with compressed air by the plant in which it is integrated.

1. (If the rotary knob of the on-off valve is secured with a padlock) Open the lock and remove it.
2. Turn the rotary knob of the on-off valve on the service unit counterclockwise as far as it will go (90°):

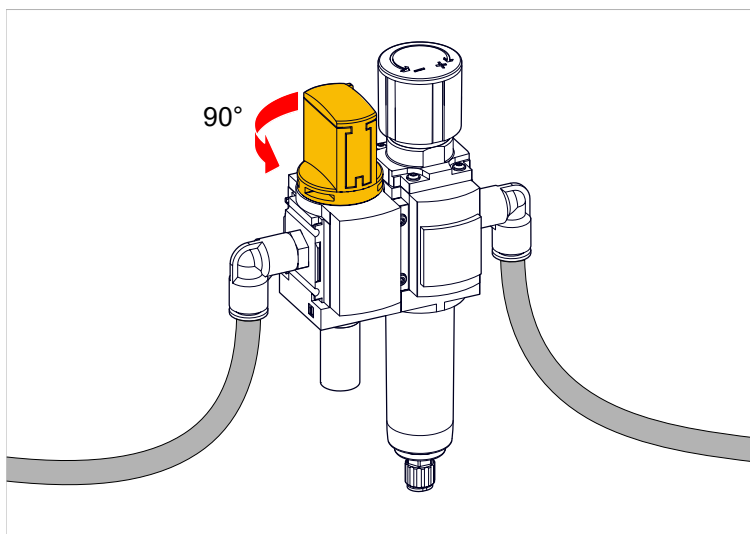

Fig. 16: Opening the on-off valve at the service unit (fig. shows closed valve).

After switching on the compressed air supply, the pressure plate starts moving to the top into home position. The apply-cycle starts as soon as the following conditions are fulfilled:

- Pressure plate is in home position
- Control signals are active (machine is online)
- Interlock circuit is closed (protection door is closed)

Deactivating

CAUTION!

After switching off the compressed air supply, the pressure plate of the applicator moves down into end position. Hazard of damage to the applicator by products passing by.

- ▶ Stop the conveyor or
- ▶ Make sure that no products pass by or
- ▶ Fix the applicator pressure plate in home position

1. Stop the machine, to which the applicator is attached.

2. Switch off the compressed air supply (using an appropriate switch at the plant or the manual on-off valve at the service unit).

After switching off the compressed air supply, the pressure plate of the applicator moves down into end position.

CLEANING

Safety



WARNING!

Dangerous situations may arise during maintenance and cleaning work. Accidents may occur due to mechanical or electrical effects if the relevant safety instructions are not observed!

- ▶ Switch off the machine before cleaning or maintenance and completely disconnect it from the main power supply. Depending on the machine type, it may be necessary to pull out the mains power connecting line (refer to the user manual of the machine)!
- ▶ Never allow liquid to get into the machine!
- ▶ Do not spray the machine with spray bottles or sprays! Use a cloth wetted with cleaning agent!
- ▶ Repairs to the machine must only be made by trained service technicians!

Cleaning interval

- ▶ Clean the machine regularly.

The frequency depends on the following factors:

- Operating conditions
- Daily operating duration

Cleaning instructions



WARNING!

Using sharp cleaning materials may cause damage.

- ▶ Do not use any cleaning agents or materials that could damage or destroy the paint finish, labelling, type plates, electrical component, etc.
- ▶ Do not use any scouring cleaning agents or any cleaning agents that could dissolve plastic.
- ▶ Do not use acid or alkaline solutions.

Cleaning agents:

- Compressed air, vacuum cleaner (if available)
- White spirit (ethanol) or isopropyl alcohol

Proceeding:

- ▶ Blow away or suck off any dust and abrasive particles with compressed air or a vacuum cleaner (if any of the two is available)
- ▶ Moisten a cloth with white spirit and wipe the machine with it.

Service unit

When the condensate level has reached the “Max.” mark:

- ▶ Drain condensate.

At low flow rate despite unchanged pressure setting:

- ▶ Change filter cartridge.

|| For instructions on how to do this, see the enclosed operating instructions for the service unit. ||

FAULT CORRECTION**Compressed air shutdown in the event of a malfunction**

In the event of a malfunction at the applicator, e.g. paper jam between the labeler and applicator, the applicator can be depressurized using the manual switch-on valve (fig. below) of the maintenance unit. In this way, the malfunction can be rectified safely, independently of the system compressed air supply.

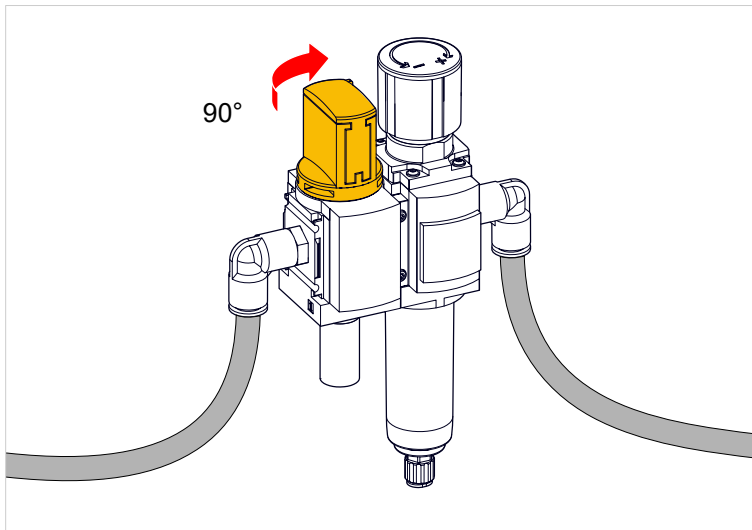

Fig. 17: Close the manual on-off valve (turn clockwise as far as it will go; the figure shows the closed valve).

Status

In the event of faults occurring on the machine, evaluate the status reports of the applied print & apply machine before doing anything.

Refer to the service manual of the applied print & apply machine, chapter “Index of parameter names and error messages” > “Numerics”. Search there for the status number of the status message that has occurred.

Call service

If you are not authorised to carry out diagnosis and fault correction work, call your technician or the authorised service. The appropriate documentation and spare parts are available to the service personnel in order to carry out repair work of a sufficient quality.

Appendix

PNEUMATIC DIAGRAMS

Pneumatic diagram LA-TO/ LA-TO TD

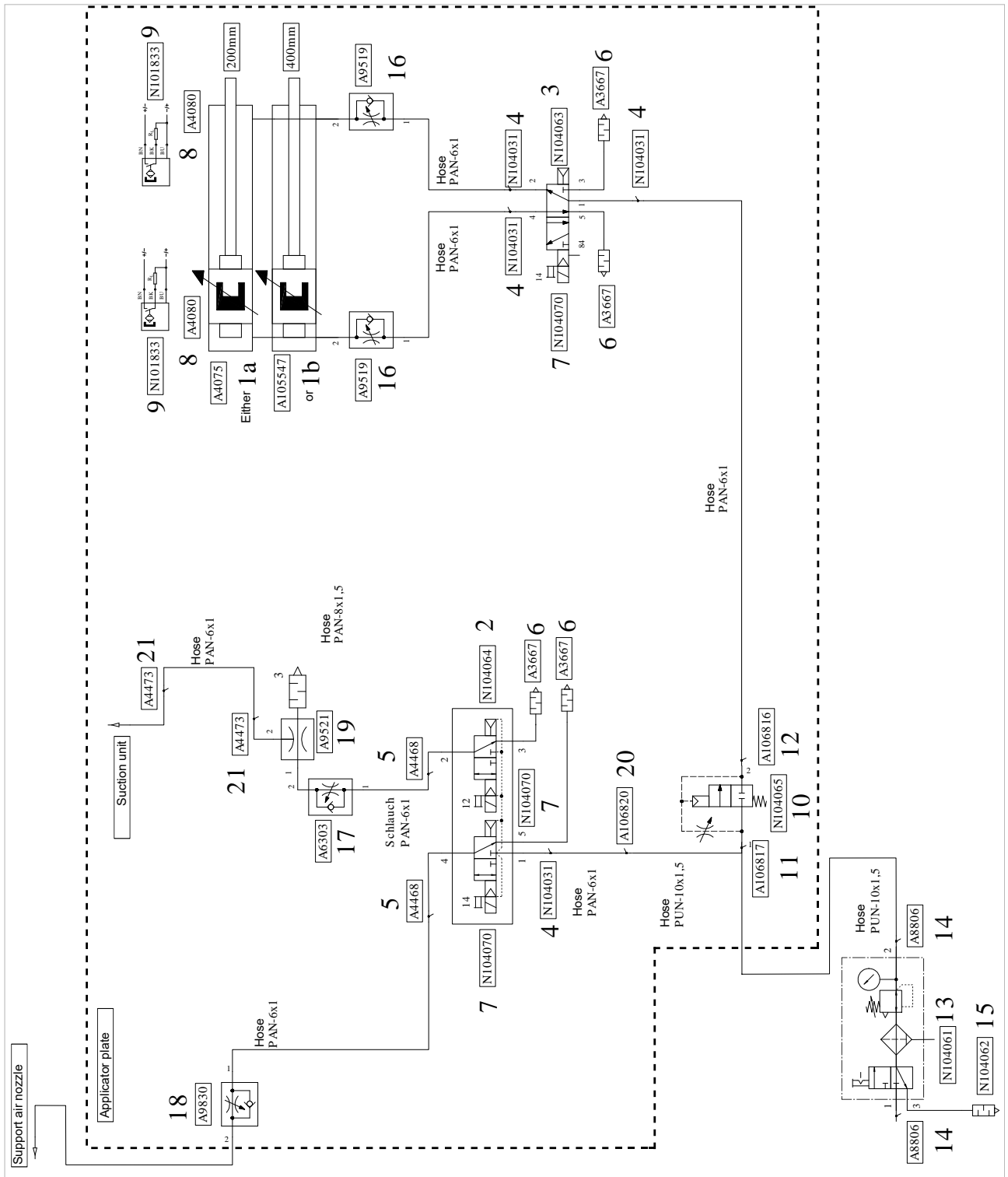

Fig. 18: Pneumatic diagram LA-TO.

OVERVIEW: HOLES IN THE PRESSURE PLATES

Article no.	Size (WxL in mm)	No. of holes	Hole distance in W	Hole distance in L
A103966	80 x 80	25	14	14
A103967	125 x 125	54	13	19
A9415	110 x 160	35	21	22
A9410	160 x 210	48	26	24,5

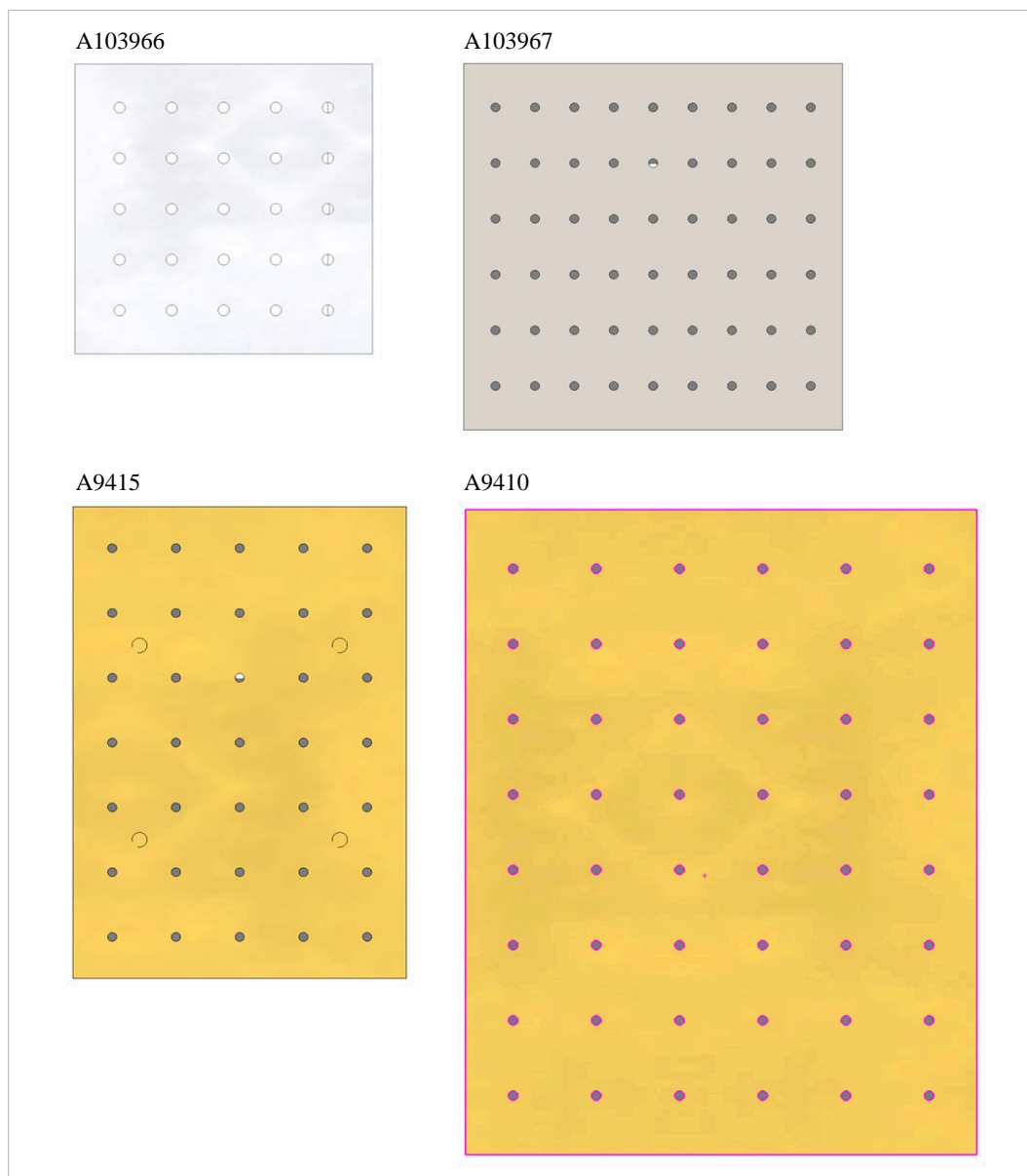

Fig. 20: Arrangement of the holes in the applicator pressure plates.

EU DECLARATION OF INCORPORATION

(Translation of original version)

We, Novexx Solutions GmbH
 Ohmstraße 3
 D-85386 Eching
 Germany

hereby declare that the partly completed machine designated below has been designed and built in such a way as to be in conformity with the safety and health protection requirements of directive 2006/42/EC, annex I, which are marked „fulfilled“ in the following table „Appendix regarding the Declaration of Incorporation“.

The special technical documents in accordance with appendix VII part B of directive 2006/42/EC have been created. We undertake to forward the special technical documentation in respect of the partly completed machine to national authorities at their request. We shall submit them by means of electronic data carrier.

The partly completed machine designated herein is furthermore in compliance with the provisions of directive 2014/30/EU (EMC) and directive 2011/65/EU(RoHS, in the currently valid version).

The designated partly completed machine must not be placed in operation until it has been determined that the machine in which the partly completed machine has been installed is in compliance with the provisions of directive 2006/42/EG.

Models	LA-TO / LA-TO XL LA-TO touch down / LA-TO XL touch down LA-TO BO / LA-TO BO XL LTP / LTPV LA-SO LTSI / LTSA / LTMA
General designation	Applicator
Applicable EU directive	2006/42/EG (Maschinery) 2014/30/EU (EMC) 2011/65/EU (RoHS)
Applied harmonized standards, especially	EN ISO 12100 : 2010 EN ISO 4414 : 2010 EN 62638-1:2024/A11:2017
The person authorized to compile technical documents	Novexx Solutions GmbH (for address see above)

Eching, 3.11.2023

Alfredo Sansone
 Head of Supply Chain and Operations and Compliance

Appendix regarding the Declaration of Incorporation

List of the essential health and safety requirements applied and fulfilled for the product named in the declaration of incorporation, relating to the design and construction of machinery.

Number Annex I	Designation	Not applicable	Fulfilled	Remark
1.1	General remarks			
1.1.2.	Principles of safety integration		X	
1.1.3.	Materials and products		X	
1.1.4.	Lighting	X		
1.1.5.	Design of machinery to facilitate its handling		X	
1.1.6.	Ergonomics	X		
1.1.7.	Operating positions	X		
1.1.8.	Seating	X		
1.2.	Control systems			
1.2.1.	Safety and reliability of control systems	X		
1.2.2.	Control devices	X		
1.2.3.	Starting	X		
1.2.4.	Stopping			
1.2.4.1.	Normal stop	X		
1.2.4.2.	Operational stop	X		
1.2.4.3.	Emergency stop	X		
1.2.4.4.	Assembly of machinery	X		
1.2.5.	Selection of control or operating modes	X		
1.2.6.	Failure of the power supply		X	
1.3.	Protection against mechanical hazards			
1.3.1.	Risk of loss of stability	X		
1.3.2.	Risk of break-up during operation		X	
1.3.3.	Risks due to falling or ejected objects	X		
1.3.4.	Risks due to surfaces, edges or angles		X	
1.3.5.	Risks related to combined machinery	X		
1.3.6.	Risks related to variations in operating conditions	X		
1.3.7.	Risks related to moving parts			Requires protective device [8]

⁸ Installation by the system integrator

Number Annex I	Designation	Not applicable	Fulfilled	Remark
1.3.8.	Choice of protection against risks arising from moving parts			
1.3.8.1.	Moving transmission parts	X		
1.3.8.2.	Moving parts involved in the process			Requires protective device ^a
1.3.9.	Risks of uncontrolled movements	X		
1.4.	Required characteristics of guards and protective devices			
1.4.1.	General requirements			a
1.4.2.	Special requirements for guards			
1.4.2.1.	Fixed guards	X		
1.4.2.2.	Interlocking movable guards			a
1.4.2.3.	Adjustable guards restricting access	X		
1.4.3.	Special requirements for protective devices	X		
1.5.	Risks due to other hazards			
1.5.1.	Electricity supply		X	
1.5.2.	Static electricity		X	
1.5.3.	Energy supply other than electricity		X	
1.5.4.	Errors of fitting		X	
1.5.5.	Extreme temperatures		X	
1.5.6.	Fire		X	
1.5.7.	Explosion	X		
1.5.8.	Noise		X	
1.5.9.	Vibrations	X		
1.5.10.	Radiation		X	
1.5.11.	External radiation		X	
1.5.12.	Laser radiation	X		
1.5.13.	Emissions of hazardous materials and substances	X		
1.5.14.	Risk of being trapped in a machine	X		
1.5.15.	Risk of slipping, tripping or falling	X		
1.5.16.	Lightning	X		
1.6.	Maintenance			
1.6.1.	Machinery maintenance		X	
1.6.2.	Access to operating positions and servicing points		X	

Number Annex I	Designation	Not applicable	Fulfilled	Remark
1.6.3.	Isolation of energy sources		X	
1.6.4.	Operator intervention		X	
1.6.5.	Cleaning of internal parts	X		
1.7.	Information			
1.7.1.	Information and warnings on the machinery		X	
1.7.1.1.	Information and information devices	X		
1.7.1.2.	Warning devices	X		
1.7.2.	Warning or residual risks		X	
1.7.3.	Marking of machinery		X	
1.7.4.	Instructions		X	
1.7.4.1.	General principles for the drafting of instructions		X	
1.7.4.2.	Contents of the instructions		X	
1.7.4.3.	Sales literature		X	

Index of parameter names and error messages

A

Applizier-Modus [24](#), [24](#)
Apply comp. time [26](#)

B

Blow on time [25](#)

D

Dwell time [25](#)

L

Label pres. sensor [27](#)

P

Position Timeout [25](#), [26](#)

R

Restart delay [26](#)

T

Touch Down Sens. [25](#)
TouchDownTimeout [24](#)

Telephone: +49-8165-925-0 | www.novexx.com

NOVEXX«
SOLUTIONS

Novexx Solutions GmbH

Ohmstraße 3
85386 Eching
Germany