

OPERATING MANUAL

LTP / LTPV Applicators

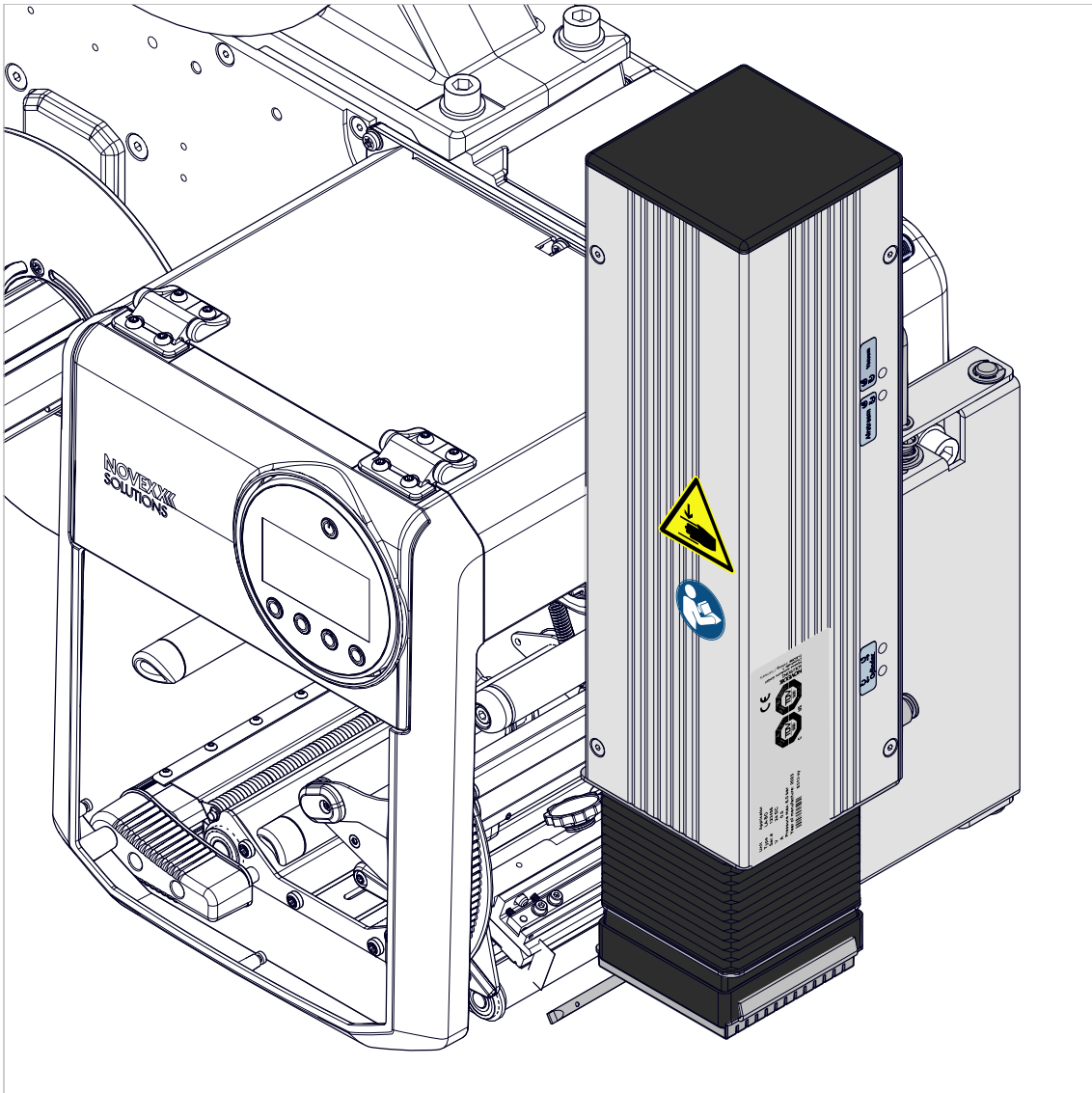

Content

Please Note -5

General information -5

Validity of this manual and required compliance -5

How information is represented -6

Notes on installation and repair work -7

For your safety -8

Intended use -8

Information and qualification -8

Safety functions -10

Operating safety of the machine -13

Warning symbols on the machine -16

Product description -17

Technical data -17

Label stock -17

Performance data -17

Dimensions -17

Connections -17

Ambient conditions -17

Overview -18

Product name -18

Intended Use of System -18

System requirements -18

Functionality -19

Component overviews -20

Parameter Reference -22

Position of the applicator parameters in the parameter menu -22

Apply mode -22

Blow on time -22

TouchDownTimeout -22

Position timeout -23

Restart delay -23

Apply comp. time -23

Label pres. sensor -23

Setup -24

Assembly -24

Preparing the connection cable for the interlock circuit -24

Mounting on XPA 93x -25

Installing the service unit -26

Compressed air -27

Settings -29

Activating the applicator **-29**

Punching the Vacuum Applicator Plate (LTPV) **-29**

Setting the upper limit **-30**

Operation -31

Activating/deactivating the applicator **-31**

Activating **-31**

Deactivating **-31**

Exchanging the pressure plate **-32**

LTP **-32**

LTPV **-32**

Valves setting **-33**

Butterfly valves **-33**

Setting the vacuum at the pressure plate (LTPV) **-34**

Setting the support air **-34**

Checking the transfer process **-35**

Cleaning **-37**

Safety **-37**

Cleaning interval **-37**

Cleaning instructions **-37**

Fault correction **-38**

Status **-38**

Call service **-38**

Appendix -39

Pneumatic diagrams **-39**

EU Declaration of Incorporation **-1**

Appendix regarding the Declaration of Incorporation **-2**

Please Note

GENERAL INFORMATION

Validity of this manual and required compliance

Contents

The complete operating manuals for the LTP and LTPV applicators consist of the following parts:

- Operating manual (for operating and service personnel)
- Service manual (for service personnel)
- Spare parts catalogue (for service personnel)

The present *operating manual* describes the installation and operation of the LTP / LTPV applicators. For safe and proper operation of the print & apply system with attached LTP / LTPV, it is indispensable to consult the operating manual for the relevant print & apply system too.

For technical questions not covered in this operating manual:

→ Follow the instructions of the service manual for the applicator or the print & apply system
or

→ Request a service technician from our sales partner.

Our sales partner's customer service department is available especially for configuration settings and malfunctions.

Device designation

LTP / LTPV stands for „Light Touch Pneumatic“ respectively „Light Touch Pneumatic Vacuum“.

LTP and LTPV are both available in different designs and versions. For details refer to chapter **Product description**  on page 17.

Technical release

01/2024

Liability

NOVEXX Solutions reserves the right:

- to make changes in design, parts and software and to use equivalent parts instead of those specified for the purpose of technological progress.
- to change information in this manual.

Any obligation to extend these changes to machines previously delivered is excluded.

Copyright

NOVEXX Solutions retains all rights to this manual and its appendices. Reproduction, reprint or any other type of duplication, including parts of the manual, are permitted only with written approval.

Printed in Germany

Manufacturer

NOVEXX Solutions GmbH
 Ohmstrasse 3
 D-85386 Eching, Germany
 Tel.: +49-8165-925-0
www.novexx.com

How information is represented

Explanation of symbols

To enhance readability and make information easier to find, different types of information are identified:

- Instruction with no order of tasks assigned
- 1. Numbered instructions introduced by preceding text
- 2. The specified order must be followed!
- ▮ Special note for action that must be performed.
- ⊖ Explanation of an error cause in the reference of error messages.
 - Enumeration of features
 - Other feature



The Experts symbol identifies activities that are reserved exclusively for qualified and specially trained personnel.



The information symbol identifies notes and recommendations as well as additional information.

Notes about hazards and risks

Important instructions that must absolutely be followed are specially highlighted:



WARNING!

A warning symbol refers to risks that can result in severe or fatal injuries! The note contains safety measures to protect affected persons.

→ Instructions must be followed without exception.

CAUTION!

A caution symbol refers to risks that can result in property damage or personal injury (minor injuries). The note contains instructions for preventing damage.

→ Instructions must be followed without exception.

Illustrations

Illustrations appear in the text where required. References to these illustrations are shown in [square brackets] containing the number of the illustrations. Uppercase letters after an illustration number, for example [12A], refer to the corresponding item within the illustration.

Parameters

Parameters in the parameter menu are represented in the format MENU NAME > Parameter name in grey type.

FOR YOUR SAFETY

Intended use

**WARNING!**

The device described here is „partly completed machinery“ as defined by machinery directive 2006/42/EC!

→ Do not set the applicator in operation until it has been determined that the machine in which the applicator will be installed meets the requirements of directive 2006/42 EC, appendix IIA.



Although the applicator is „partly completed machinery“ under the terms of the machinery directive, for reasons of clarity it is called „machine“ or „applicator“ in this manual

The LTP/LTPV applicator is a device for automatic attachment of self-adhesive labels, which are supplied to the applicator by an XPA 93x print & apply system.

The LTP/LTPV is firmly attached to the XPA 93x. In contrast to direct dispensing from the dispensing edge of the machine onto the product, the LTP/LTPV can bridge distances of up to 20 cm between dispensing edge and product. The „light touch“ function enables the LTP/LTPV to attach labels on products with varying heights.

Any other type of or more extensive application will be considered non-intended use. NOVEXX Solutions shall assume no liability for damage resulting from non-intended use of the machine.

Information and qualification

Ensuring the necessary qualification

- Only fully trained and authorised personnel are permitted to operate, adjust and maintain the machine.
- Service work must only be performed by qualified and appropriately trained technical specialists (service technicians) or the customer service department.
- Areas of responsibilities for operating and servicing the machine must be clearly defined and consistently observed.
- Personnel must also be regularly instructed in on-the-job safety and environmental protection.

Qualification for operation

The instruction provided for the operating personnel must ensure:

- that the operating personnel can use the machine independently and without danger.
 - that the operating personnel can rectify minor operating faults (for example a paper jam) independently.
- At least 2 persons should be instructed in operation.
- Have a sufficient quantity of label materials available for tests and instruction.

Qualification for system integrators and service technicians

Knowledge required to install the device and perform service work must be demonstrated through appropriate qualification. Only service personnel with technical training are able to assess the tasks to be performed and recognise potential dangers.

- Knowledge acquired through technical training in mechanics and electronics (for example in Germany the training to become a mechatronics engineer).

- Participation in a technical training course for the corresponding device offered by the manufacturer.
- The service personnel must be acquainted with the functionality of the device.
- The system integrator must be acquainted with the functionality of the system into which the device is being integrated.

Tasks	System integrator	Operator	Service technician
Install the machine	X		
Connect	X		
Make settings	X		
Switch on/off	X	X	X
Insert/change material/ribbon	X	X	X
Application-related settings	X	X	X
Rectify minor operating faults ^a	X	X	X
Clean the machine		X	X
Rectify major operating faults ^b			X
Settings to the electronics/ mechanics			X
Repairs			X
 Manual:	Service manual	Operating Manual	Service manual, spare parts catalogue

[Tab. 1] An example of the distribution of tasks among different qualified personnel.

- a) For example faults during label feeding
- b) For example replacement of lamp or printhead

Making note of information



WARNING!

The device can only be operated safely and efficiently by complying with all of the requisite information!

- Carry out the installation, connection, programming, setting, and repairing of the machine exclusively in accordance with the specifications in this manual.
- Before beginning operation, read this operating manual and the operating manual of the dispenser/print-dispenser and follow all of the instructions.
- Observe all additional safety and warning information given on the device.
- Only technically knowledgeable persons are permitted to operate the device and make settings on it.

Any product liability and warranty claims will not be valid unless the machine is operated according to the instructions in the operating manual.

Keep product information at hand

This user manual

- must remain readily available for operating personnel at a location near to the machine.
- must be kept in legible condition.
- If the machine is sold, it must be made available to the new owner.
- The safety and warning symbols and messages on the machine must be kept in a clean and legible state. Replace any signs that are damaged or missing.

Safety functions**WARNING!**

Danger of personal injury and property damage!

Without operational safety functions and protective equipment the LTP/LTPV may cause personal injury and property damage.

- Do not operate the machine without protective equipment.
- Do not operate the machine when the safety functions are deactivated.

Protective equipment

A separating protective device must be installed by the system integrator in compliance with the requirements of EN953. It could be a protective enclosure with a secured door, for example.

The separating protective equipment is not included in the scope of delivery of the machine.

Connecting an interlocking guard

According to the EC machinery directive, the LTP/LTPV are *partly completed machines*. In order that the completed machine matches the health and safety requirements of the machinery directive, LTP/LTPV *must* be safeguarded against access by an appropriate safeguarding device ¹ [3].

→ Connect the interlock switch [3D] of the safeguarding device to the connector [2] delivered with the applicator.

→ Plug the connector to the LTP/LTPV.

▣ Operation of the LTP/LTPV without the described safeguarding device shall be regarded as abnormal use. NOVEXX Solutions assumes no liability for damage due to abnormal use of the printer.

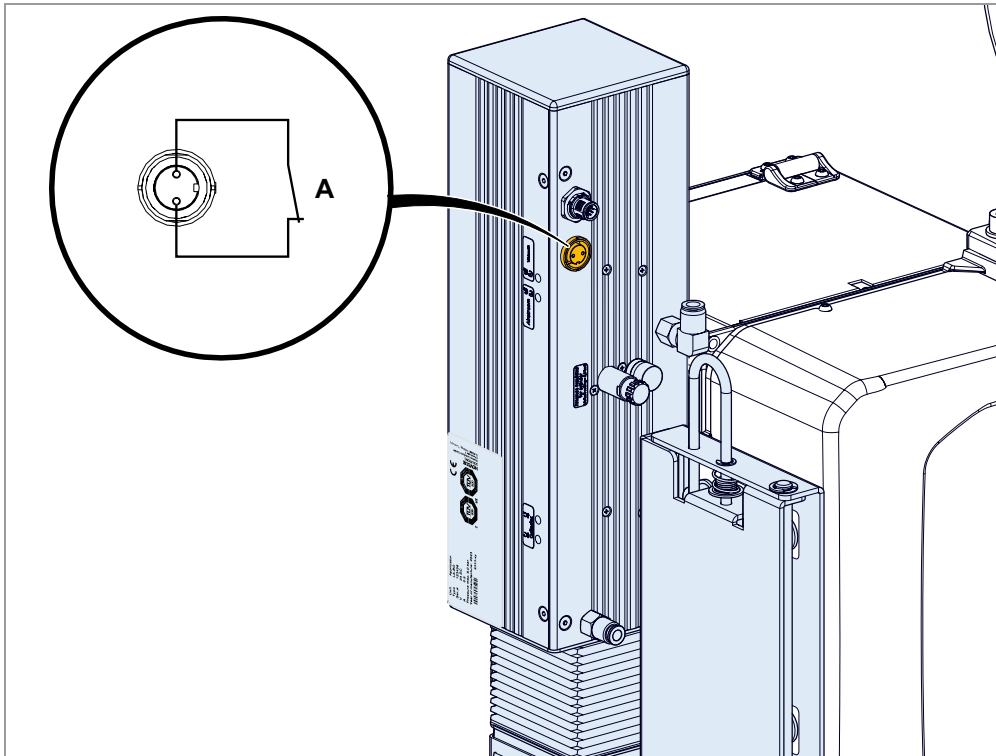

[1] Connecting the interlock switch (A) of the safeguarding device (or an emergency-stop switch) to a LTP/LTPV (here: LTPV).

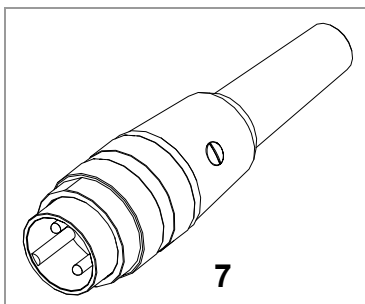

[2] Plug that comes with the LTP/LTPV for connecting an interlock switch to the LTP/LTPV (article number: A102076).

1) Movable interlocking guard according to EN ISO 12100-1, 3.25.4

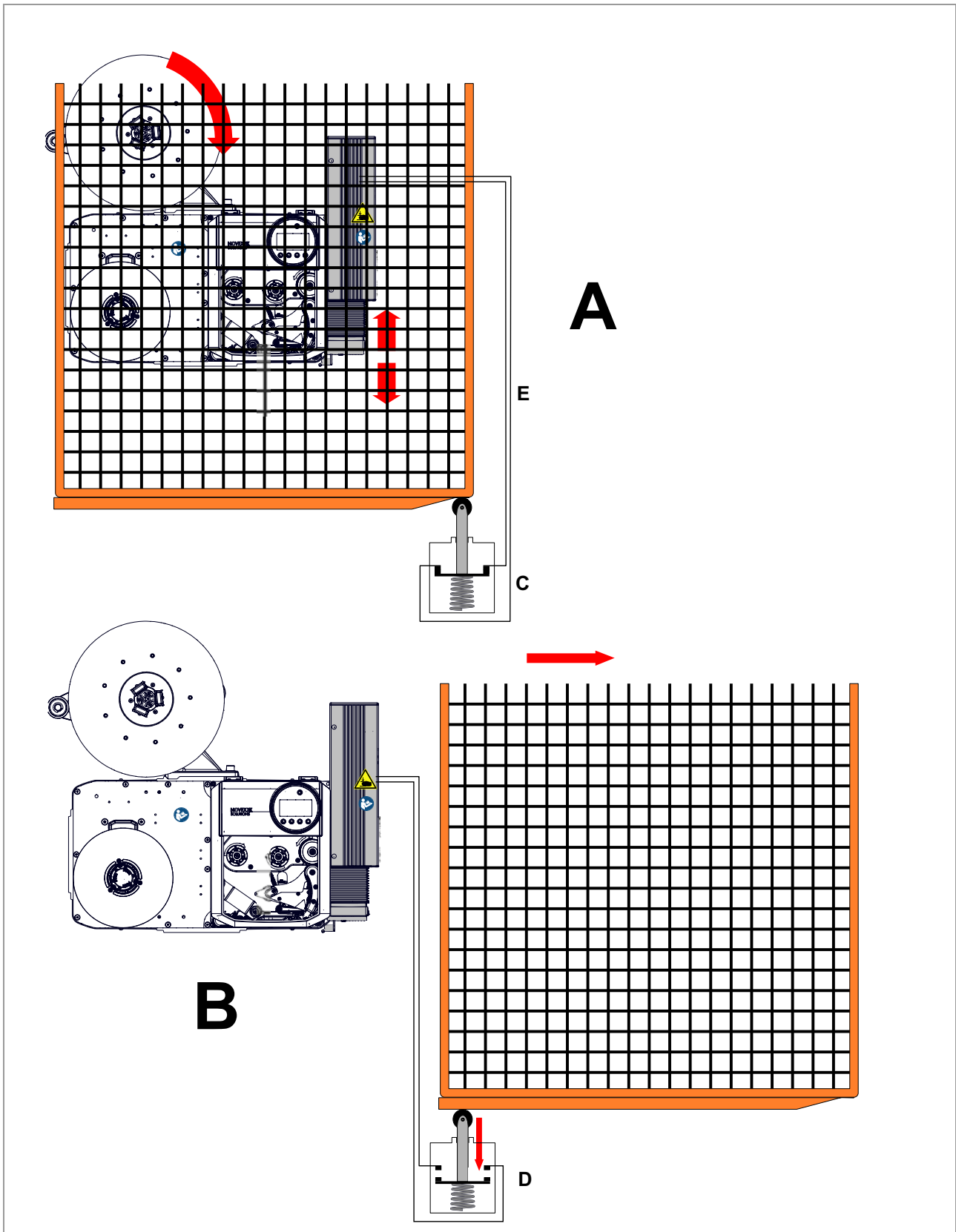

[3] Diagram of a movable interlocking guard:
A Protective guard closed. Interlock switch connected (C). Applicator is working.
B Protective guard open. Interlock switch not connected (D). Applicator stopped.

Emergency Stop

An external Emergency Stop device must be installed by the system integrator. It could be an Emergency Stop button located outside of the protective equipment, for example. The button must be pressed if a hazardous situation occurs or in the event of an emergency.

The external Emergency Stop device is not included in the scope of delivery of the machine.

Checking the safety functions

The following safety functions can be checked by the user or a service technician:

Safety function	Functional check
Emergency Stop	<p>→ Activate the Emergency Stop device (for example press the Emergency Stop button).</p> <p>The applicator must stop immediately.</p>
Protective equipment	<p>→ Interrupt the safety switch circuit (for example open the safety door).</p> <p>The applicator must stop immediately.</p>
Switching-on valve	<p>→ Switch on compressed air.</p> <p>The applicator foot moves from the end position <i>slowly</i> up to the home position. If the movement occurs abruptly, the switching-on valve must be adjusted by a service technician.</p>

[Tab. 2] Overview: Checking the safety functions

Operating safety of the machine

Intended use

→ The machine must only be used in accordance with the specifications in section **Intended use** on page 8.

Installation, maintenance**WARNING!**

Improper usage of the machine can lead to accidents, material damage and loss of production!

- When installing the machine, check for visible shipment damage. Immediately inform NOVEXX Solutions of any damage.
- When installing the machine, consider the admissible ambient conditions.
- When installing the machine, make sure that it can not tip over.
- When installing the machine, provide a supply disconnecting device and an emergency stop device.
- Install the supply disconnecting device and the emergency stop device in a way that they are easy reachable.
- Lay the connection cable and pneumatic hoses so that no one can trip over them.
- Check if all safety functions are functioning properly.
- Only put the machine into operation if it is in flawless condition.
- Only perform alterations or conversions to the machine with the consent of NOVEXX Solutions' customer service.
- Max. admissible operating air pressure: 6 bar
- Only link the applicator to devices that fulfil the ES1 circuit requirements specified in EN 62368-1.
- Fasten the pneumatic hoses in place to prevent them from whipping.
- Replace faulty pneumatic hoses immediately.
- Only put the machine into operation after at least one successful test run has been completed.
- Only use original replacement parts.

**WARNING!**

Danger of crushing between applicator and dispensing edge as well as between applicator and conveyor!

- Avoid access to the running machine by installing higher-level protective guards ^a.

a) Movable, separating guards according to EN 953

Warning of injuries due to electrical shock**WARNING!**

The machine to which the applicator is attached works with mains voltage! Contacting electrically live components can cause lethal electrical shocks and burns.

- Switch the machine off before cleaning and servicing.
- Keep the machine dry.
- If a liquid gets into the machine, switch off the machine immediately. Notify a service technician.
- Only link the applicator to devices that fulfil the ES1 circuit requirements specified in EN 62368-1.
- In case of emergency switch off the machine.

Warning of injury hazards from mechanical components



WARNING!

Danger of crushing between the machine and conveyor equipment and between movable parts of the applicator!

- The machine may only be operated with higher-level protective equipment.
- Never remove or bypass the protective equipment that is designed to prevent reaching in while the machine is in operation.

Danger of injury due to moving and rapidly rotating parts!

- Maintain a safety clearance from the machine when it is in operation.
- Never reach into a machine that is running.
- Switch off the machine before making any mechanical adjustments.
- Keep clear of the area around moving parts even when the machine is stopped if there is any possibility of the machine starting up.

Entanglement hazard!

- When working in the vicinity of machines in operation, do not wear ties, loose clothing items, jewellery, wrist watches or similar objects on your body.
- Long hair must be kept in a hair net and must not be worn loose.

Tripping hazard!

- Lay the connection cable and pneumatic hoses (if fitted) so that no one can trip over them.

Warning symbols on the machine

CAUTION!

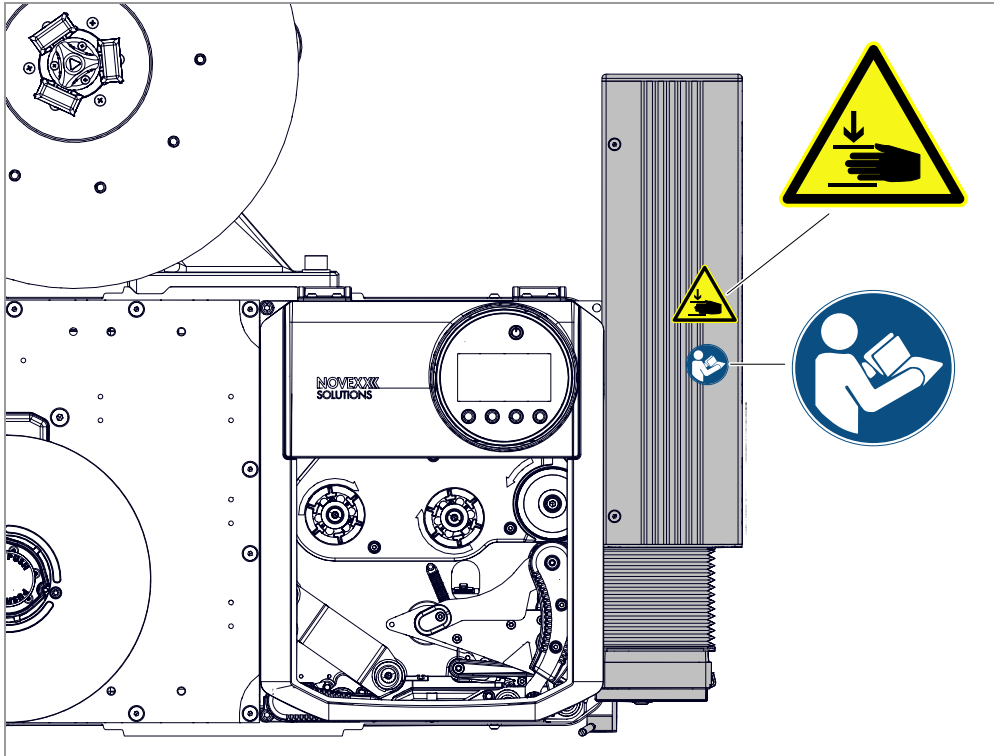

Warning symbols on the machine provide important information for the operating personnel.

- Do not remove warning symbols.
- Replace missing or illegible warning symbols.



[4] Warning note on the LTP/LTPV.

Meaning of the warning symbols:

Warning symbol	Meaning	Order No.
	The warning symbol "Danger of crushing" warns of dangerous movements of the device that could lead to crushing. Switch off the device previously.	A103530
	The blue label 'Read manual' demands that users read the unit instructions.	A5331

[Tab. 3] Meaning of the warning symbols

Product description

TECHNICAL DATA

Label stock

Label type	Self-adhesive (Papier, PE, PP, PVC, PA)
Label width	LTP: 30-80 mm
	LTPV: 12-80 mm
Label length	LTP: 30-80 mm
	LTPV: 12-80 mm

Performance data

Labelling rate	max. 100 / min ^a
Stroke length	max. 200 mm
Application tolerance	±1 mm
Application angle	90° ± 3°
Product speed	max. 20 m/min

a) At a stroke length of 20 mm and a dispensing speed of 40 m/min.

Dimensions

Weight	4.5 kg
W x H x D	100 x 250 x 450 mm

Connections

Air pressure	4-6 bar (max. admissible: 8 bar)
Air consumption	0.3 liter/stroke
Power consumption	15 VA
Supply voltage	24 VDC

Ambient conditions

Operating temperature	5 to 40°C
Storage temperature	0 to 70°C
Humidity	30 to 80%, non condensing
Noise	< 70 dB(A)
Protection class	IP21

OVERVIEW

Product name

LTP/LTPV = Light Touch Pneumatic / Light Touch Pneumatic Vacuum

Light Touch

Light Touch means that the applicator reverses shortly after it encounters resistance, i.e. a product. This has the advantage that it also enables products of different heights to be labeled without needing to adjust the applicator.

Pneumatic

The LTP/LTPV is driven by compressed air.

Vacuum

(LTPV only) The label is held to the plastic plate on the underside of the applicator by suction and the air stream of a support air jet.

In the LTP, the suction onto the suction plate is generated by a blower that is mounted at the top end of the applicator housing.

Intended Use of System

The LTP/LTPV applicator is a device for automatic attachment of self-adhesive labels, which are supplied to the applicator by an XPA 93x print & apply system.

The LTP/LTPV is firmly attached to the respective machine. In contrast to direct dispensing from the dispensing edge of the machine onto the product, the LTP/LTPV can bridge distances of up to 20 cm between dispensing edge and product. The „light touch“ function enables the LTP/LTPV to attach labels on products with varying heights.

Installation position

Permissible installation positions for the LTP/LTPV are:

- *Vertical*, if application takes place from top to bottom (the product is located below the printer/applicator); Application from bottom to top only if a dust protection, specific to the application, is supplied by the integrator.
- *Horizontal* (the product is located next to the printer/applicator)

System requirements

Compressed air

Compressed air connection with 4-6 bar must be available. If the pressure is higher, a pressure reducer must be installed (available as accessory, article no. A9398).

Print & apply system

XPA 93x with standard dispensing edge and firmware version 1.01 or higher.

▣► The control takes place via the applicator interface of an installed 8IO board (option).

Functionality

The LTP/LTPV applicator is an additional module to be mounted to one of the above named print & apply systems (see chapter **Intended Use of System**  on page 18). The device takes over self-adhesive labels from the dispensing edge of the print & apply system, moves each of the labels to the product in a linear movement and attaches it to the product.

The label is held by a pressure plate that is driven by a pneumatic cylinder between home position and end position.

In home position, the label is taken over from the dispenser or the print & apply machine. The arrival of the pressure plate in home position is detected by a sensor at the pneumatic cylinder of the applicator. The label is peeled off the backing paper by the dispensing edge and is pushed under the pressure plate, where it is sucked on by a vacuum. Additionally, the label is blown onto the pressure plate by an air stream from the support air nozzle. Afterwards, the pressure plate moves to the end position, where the label is attached to the product.

The arrival in the end position is detected by 4 sensors which are integrated in the pressure plate. The sensors are activated, as soon as the pressure plate presses slightly against the product. This „light touch“ function enables the LTP/LTPV to label products with varying heights and especially sensitive products.

Component overviews

LTP/LTPV front side

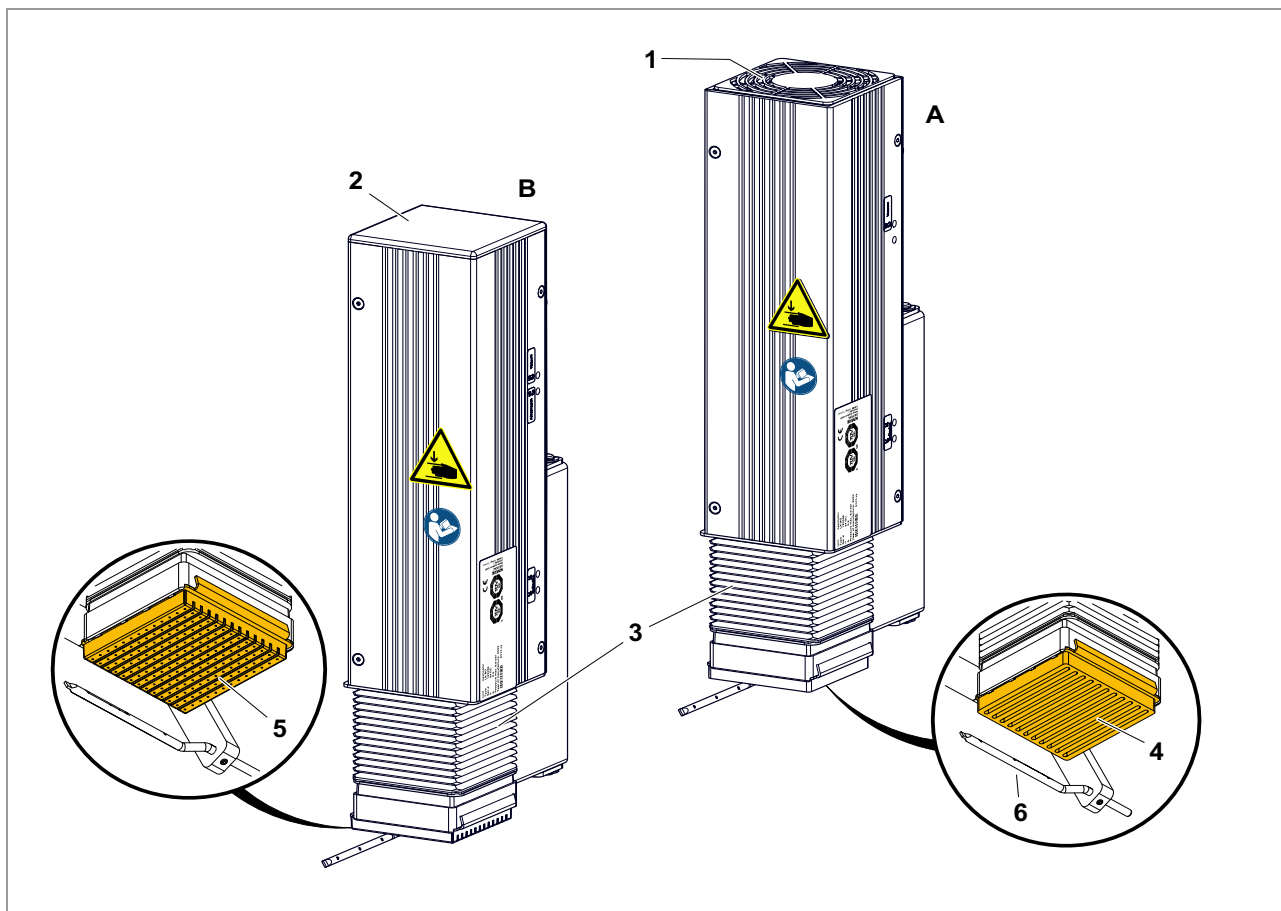

[5] Front side LTP (A) and LTPV (B).

No.	Designation
1	Blower (LTP only)
2	Housing cover (LTPV only)
3	Gaiter
4	Pressure plate (foarm, LTP only)
5	Pressure plate (plastic, LTPV only)
6	Support air nozzle

LTP/LTPV rear

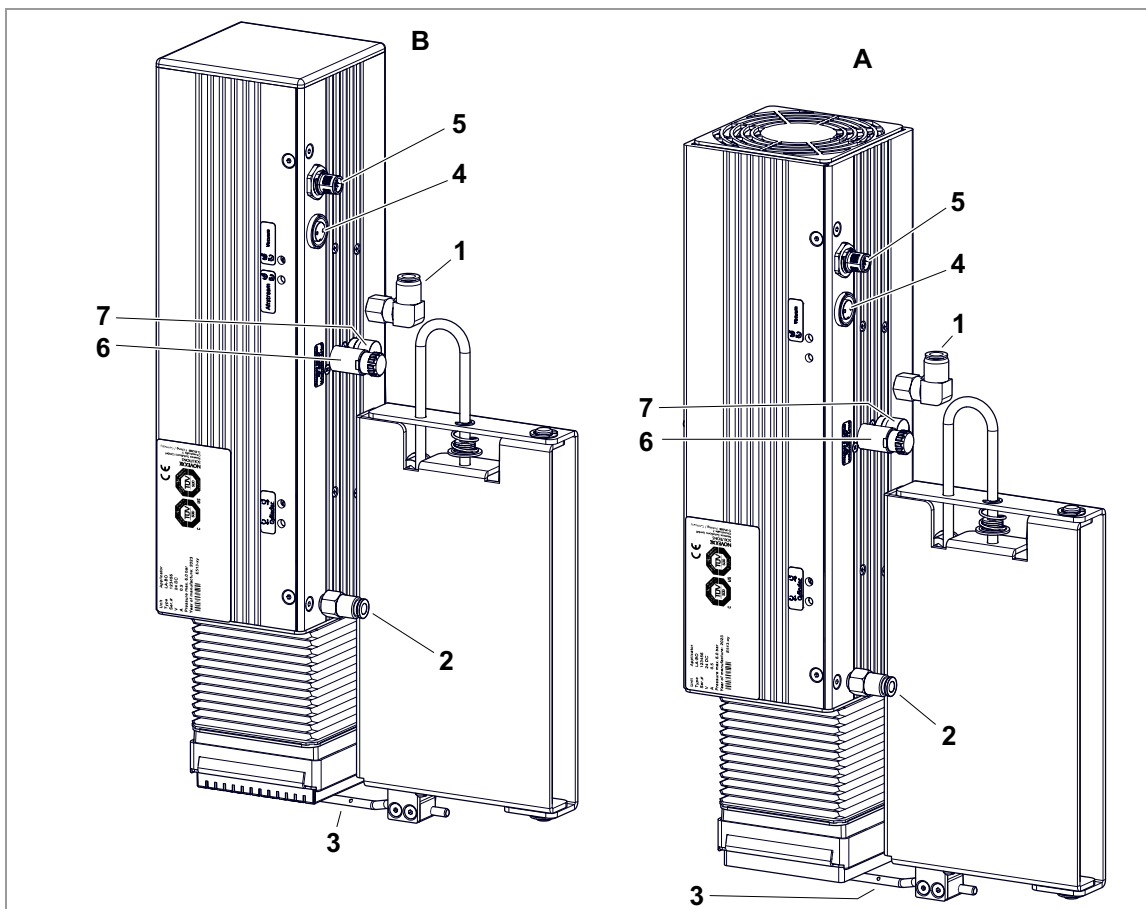

[6] Rear view of LTP (A) and LTPV (B).

No.	Designation
1	Compressed air connection
2	Support air connection
3	Support air nozzle
4	Connection for interlock switch
5	Connection to XPA 93x
6	Pressure regulator
7	Pressure indicator

PARAMETER REFERENCE







Position of the applicator parameters in the parameter menu

The parameters for controlling the applicator appear in a separate submenu under Options > 8IO 1 > Name of applicator. The prerequisite is that the optional 8IO board is present and that the applicator is activated (see below).

Activate LTP/LTPV:

→ Options> Selection > 8IO 1 > Applicator > Applicator type = „LTP/LTPV“

The submenu for LA-SO then appears:

Options
└ 8IO 1
└└ LTP/LTPV
└└└ Apply mode  on page 22
└└└ Blow on time  on page 22
└└└ TouchDownTimeout  on page 22
└└└ Position timeout  on page 23
└└└ Restart delay  on page 23
└└└ Apply comp. time  on page 23
└└└ Label pres. sensor  on page 23

Apply mode

Settings	Default setting	Step width	Easy Plug
After start sig., After print	After start sig.	--	#PC3102

Defines, if the application process starts with applying (“After start sig.”) or with printing (“After print”).

Requirements: Printjob transferred, machine is ready for operation.

- *After start sig.*: The start signal triggers the application of an already printed and dispensed label. After applying the label, the next one is immediately printed and dispensed.
- *After print*: The start signal triggers the retraction under the print head, printing, dispensing and application of a label.

Blow on time

Setting range	Default setting	Step width	Easy Plug
[0..99999] ms	50 ms	1 ms	#PC3107

Sets the duration for blowing on applicators with blow-on capability.

TouchDownTimeout

Setting range	Default setting	Step width	Easy Plug
Off, [100..99999] ms	Off	--	#PC3117

Timeout at the touchdown sensor. This time specifies the maximal wait time for the touchdown trigger event.

- *Off*: The function is switched off
- *xxxx ms*: If the specified time *xxxx ms* is exceeded without the touchdown event, the applicator continues operation in the same manner as the touchdown event would have taken place. No error message will appear in this case.

Position timeout

Setting range	Default setting	Step width	Easy Plug
[500..99999] ms	2000 ms	1 ms	#PC3109

Determines the length of time after which an applicator position error is displayed as an error. A position error is considered to have occurred if the applicator has failed to reach one or both of its end positions within the time set.

Restart delay

Setting range	Default setting	Step width	Easy Plug
[0..99999] ms	0 ms	1 ms	#PC3108

Determines the length of time after application for which no start signals will be accepted.

Apply comp. time

Setting range	Default setting	Step width	Easy Plug
[0..99999] ms	0 ms	1 ms	#PC3111

Compensation time for applicator stroke time; required for variable conveyor speed operation.

 Most applicators have a constant stroke time. If the print & apply system is driven with variable speed, this leads to different label positions on the product. With a slow conveyor speed, the touch down comes too early, with a high conveyor speed, it is too late. With the stroke time entered in the *Apply comp. time* parameter, the system corrects this effect, and therefore improves the labelling precision.

Setting instruction:

- Setup the print-dispense-apply-process with a slow conveyor speed.
- Turn the conveyor speed high.
- Adjust the labelling position by increasing the *Apply comp. time* step by step, until the labelling position is correct.

Label pres. sensor

Setting range	Default setting	Step width	Easy Plug
Off, On	Off	--	#PC3119

Activates the “label-present sensor” if the applicator has one. The sensor checks whether a label is present on the applicator. Depending on the design, this can be done before or after application. Depending on the design, it is evaluated as an error if no label is present before application, or if a label is still present on the applicator after application:

Status num: 5215
Label on appl

Status num: 5216
No label on appl

Setup

ASSEMBLY

**WARNING**

Risk of tripping!

→ Lay cables and compressed air hoses in a way that nobody can stumble over it.

**WARNING!**

Risk of injuries caused by lashing pneumatic hoses.

→ Fix pneumatic hoses against lashing.

→ Immediately replace defective pneumatic hoses.

Preparing the connection cable for the interlock circuit

The LTP/LTPV comes with a plug [7] that is intended for connecting an interlocking guard.

Tool

Small screwdriver (0.6x3.5 mm)

Assembly

→ Connect the plug [7] to the interlock switch, which is part of the interlock circuit.

See chapter **Connecting an interlocking guard** on page 11.

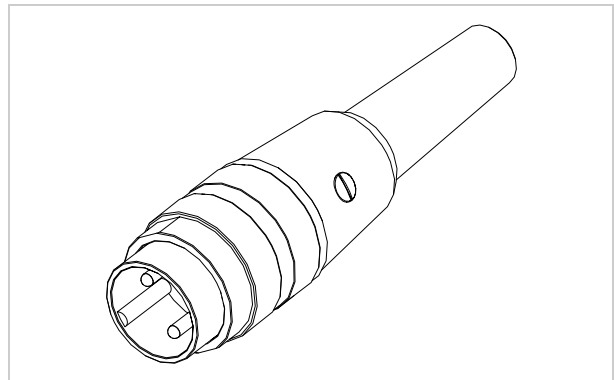

[7] Plug for connecting the interlock circuit (comes with the applicator).

Mounting on XPA 93x

Tools

Hex socket scwdriver 8 mm

Mounting the applicator:

1. Open the swivel unit. To do so, pull the locking rail [8A] upwards.

2. Screw the applicator with the swivel unit to the flange [9B] of the machine (use supplied screws [9A]).
3. Swivel the applicator into the working position. While doing so, pull the locking rail upward and snap it into the holes provided for this purpose.

4. Connect the cable [10A] to the applicator and to the machine [11].
5. Connect the interlock circuit of the protective guard to the LTP/LTPV [10B].
See chapter **Connecting an interlocking guard** on page 11.

■▶ Connecting an interlock circuit is mandatory. The LTP/LTPV must not and cannot be operated without.
6. Install the service unit.
See chapter **Installing the service unit** on page 26.
7. Connect the compressed air supply.
See chapter **Connecting the supply hose** on page 27.
8. Switch-on the XPA 93x.
9. Make settings in the parameter menu.
See chapter **Activating the applicator** on page 29.
10. Adjust the LTP/LTPV.
See chapters **Setting the distance to the dispensing edge** on page 32 and **Setting the upper limit** on page 30.

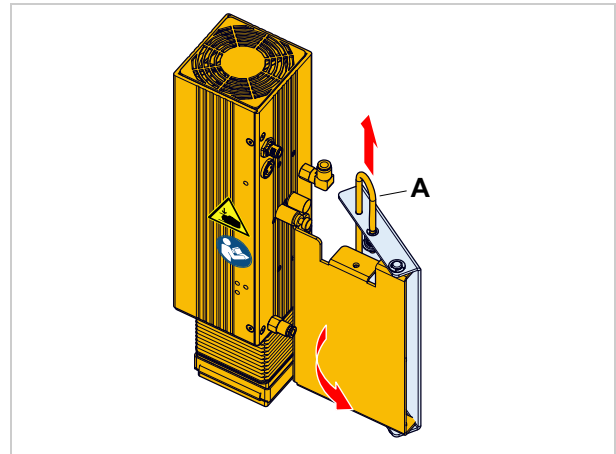

[8] Opening the swivel unit.

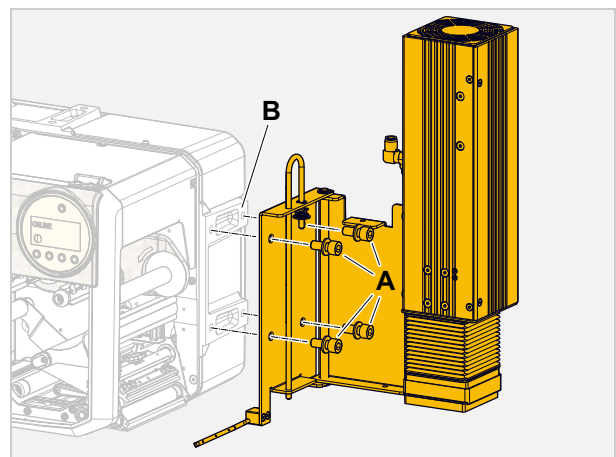

[9] Screw on the applicator with the swivel unit.

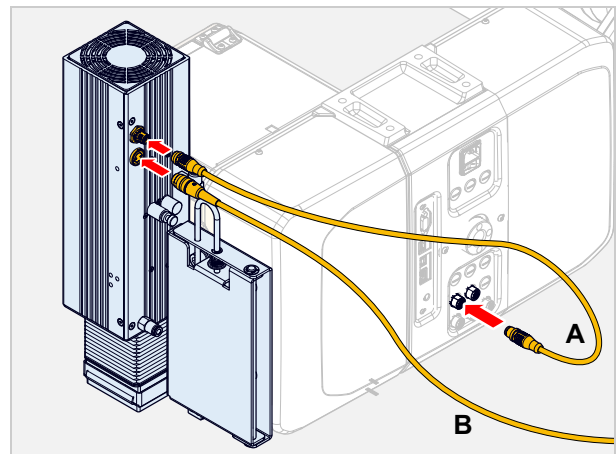

[10] Connecting the applicator.

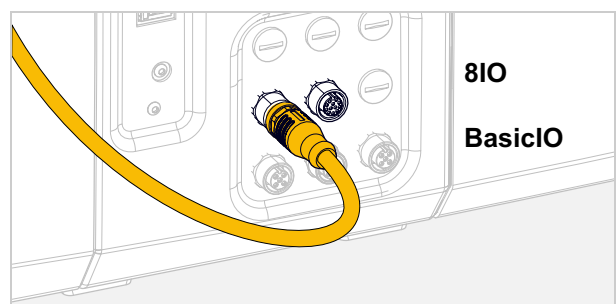

[11] Applicator connection at the 8IO board.

Installing the service unit

The service unit comes with the applicator. It consists of the following components:

- Manual on-off valve [12A]
- Filter regulator [12B] with pressure gauge [12C]
- Condensate drain [12D]

Tools:

4 mm hex screwdriver

Assembly

- Screw on the maintenance unit with the enclosed screws (M5x12) [13A].
- The condensate drain [13B] must point downwards.
- Fasten the pressure tubes so that the air flows through the pressure regulator in the direction from mark „1“ [13C] to mark „2“.

The connector marked „2“ is the compressed air outlet. This must be connected to the applicator.

☛ Mind the instruction sheet of the manufacturer, which comes with the service unit.

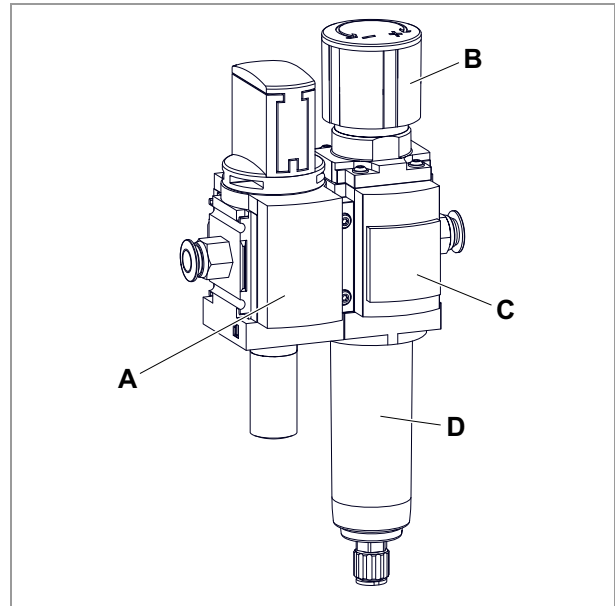

[12] Components of the service unit.

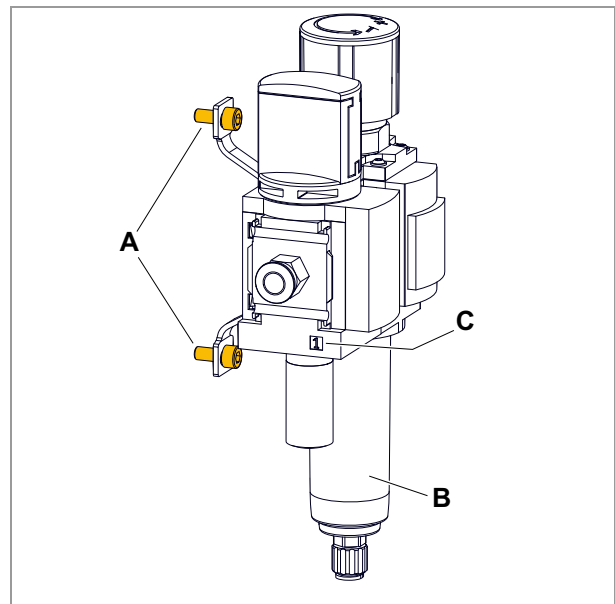

[13] Assembly of the service unit.

Compressed air

Connecting the supply hose

Prerequisites:

- Hose diameter: 8 mm
 - Max. admissible entrance pressure at the service unit: 10 bar
 - Max. admissible exit pressure at the service unit: 6 bar
1. Switch off the on-off valve. To do this, turn the rotary knob [14A] clockwise as far as it will go.
 2. Reduce the outlet pressure completely. To do this, turn the control valve knob [14B] all the way to "-".
 3. Connect the compressed air line to the connections as shown [14].
 4. Switch on the compressed air.
 5. Switch on the on-off valve. To do this, turn the rotary knob [14A] counterclockwise as far as it will go.
 6. Set the outlet pressure. To do this, slowly turn the control valve knob [14B] in the "+" direction until the pressure gauge indicates the desired outlet pressure.

► Mind the instruction sheet of the manufacturer that comes with the service unit.

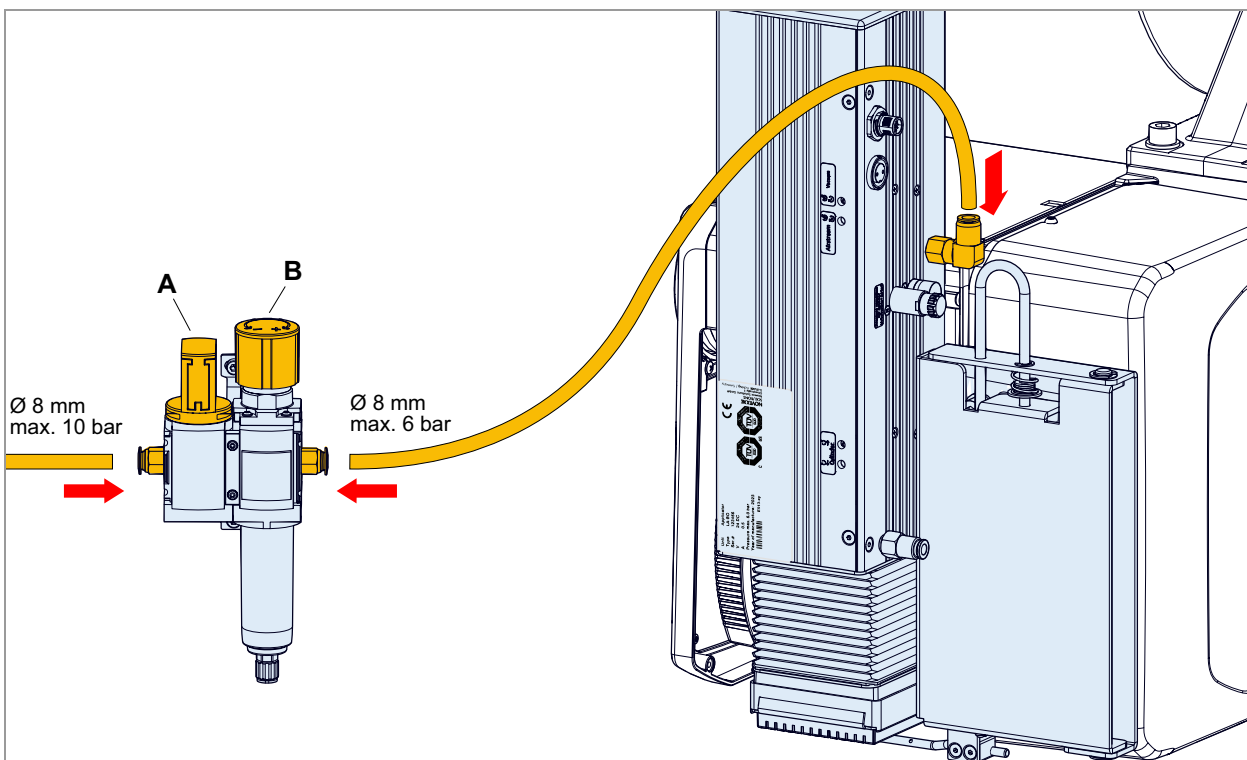

[14] Connecting the compressed air hose.

Connecting the support air nozzle

→ Connect the hose (∅ 8 mm) to connector [15A] and support air nozzle [15B].

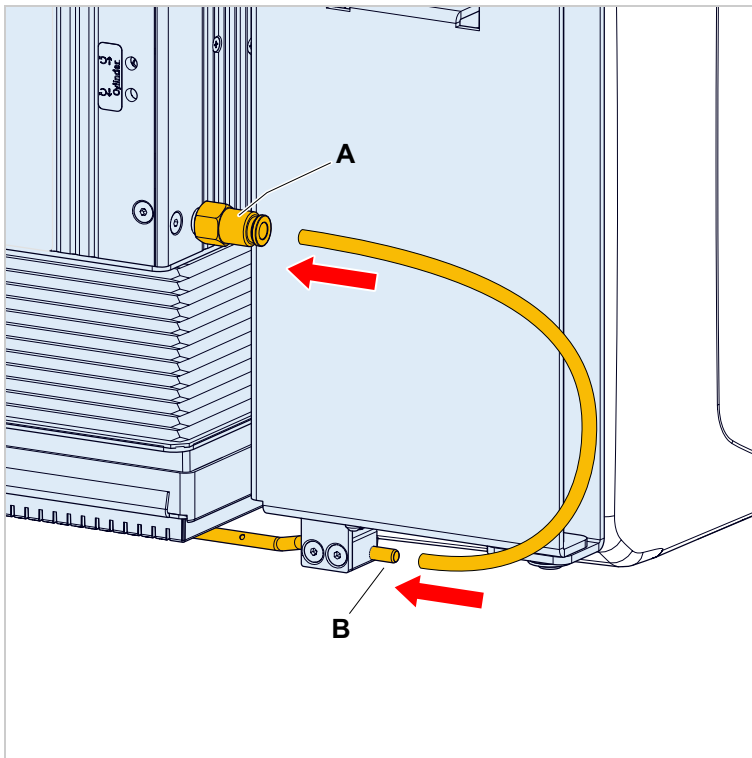

[15] Connecting the support air nozzle.

SETTINGS

Activating the applicator

→ Options > Selection > 8IO 1 > Applicator > Applicator type = „LTP - LTPV“

After activating the applicator, the submenu Options > 8IO 1 > LTP - LTPV appears. The parameters available there are used to set the applicator to the respective application situation.

For details refer to chapter **Parameter Reference**  on page 24.

For information on setting the dispensing function, see the XPA 93x service manual. In particular, the setting of the parameter Dispenser > Dispenseposition is important for the correct transfer of the dispensed label to the applicator.

→ Adjust the dispensing position so that the label is just dispensed, i.e. no longer sticks to the liner.

Punching the Vacuum Applicator Plate (LTPV)



WARNING!

Danger of cuts and crush injuries between moveable pressure plate and dispensing edge.

For this reason pay attention to the following when triggering the applicator for test or set-up purposes...

- keep a sufficient distance.
- don't touch the applicator.

Because the LTPV creates a strong vacuum but only a weak air stream at the applicator plate, the number of air openings has to be individually fitted to the labelling material that is used.

The openings in the plate are pre-formed – they simply have to be punched in the required arrangement using the supplied tool [16]. Act as follows:

1. Mark the exact position of the dispensed label on the vacuum plate.
2. Punch some of the pre-formed holes in the area which is covered by the dispensed label [17].
 - ▮▶ The punched holes must cover the whole area, but not all of the covered holes must be punched. The less holes are required to hold the label under the vacuum plate, the better! *Don't punch all of the holes in the label area!*

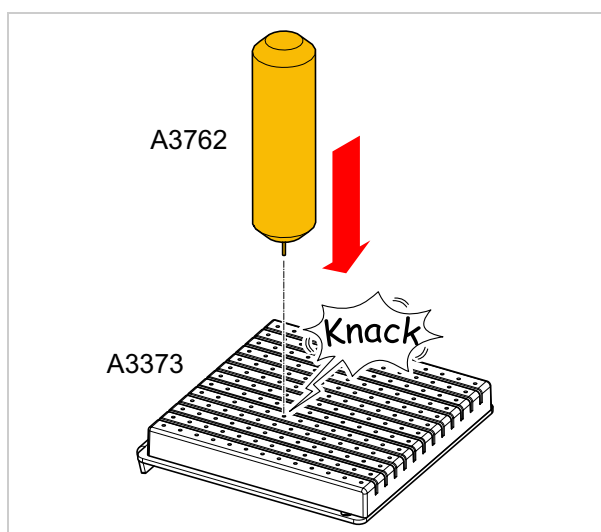

[16] Punching the pre-formed openings at the applicator plate.

▮ Under no circumstances, you may punch holes outside the area covered by the label, otherwise there will be no vacuum!

▮ Avoid punching holes very close to the label edge!

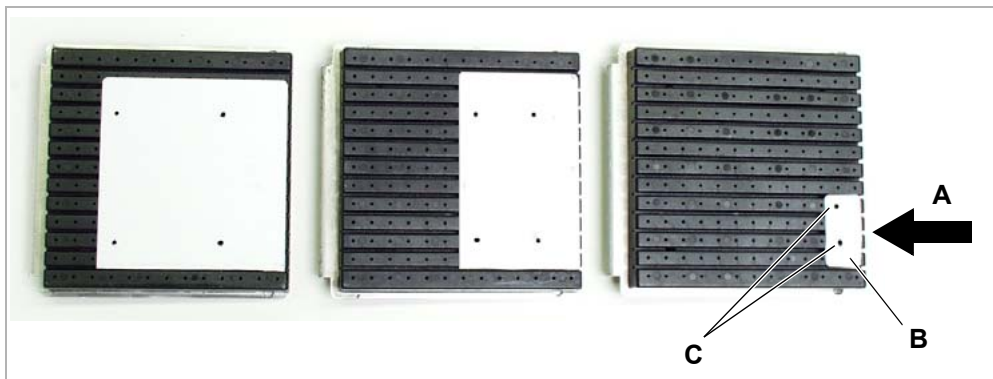

[17] Punching the air holes for different label shapes. The black dots on the labels mark the positions for the air holes.

- A Dispense direction
- B Label
- C Punched holes

3. Proceed some dispensing tests and check if the dispensed label is sucked to the vacuum plate properly. If not, punch some additional holes (not all!).
4. Repeat steps 2 and 3 until the labels stick to the vacuum plate properly.

Setting the upper limit

At the upper limit, the pressure plate must be positioned approx. 2 mm below the dispensing edge.

Setting:

1. Switch-off the machine, disconnect the compressed air supply.
2. Loosen the gaiter at its bottom end (velcro straps).
3. Elongate the applicator manually.
4. Loosen the counter nut [18A].
5. Turn the plunger in, respectively out, until the pressure plate is positioned approx. 2 mm below the dispensing edge.
 - ▮ The 2 mm rule is only a reference value. The general setting rule is: Set the applicator position as low as possible, so that the dispensed label is just pushed under the pressure plate [19].
6. Tighten the counter nut.
7. Fix the gaiter.

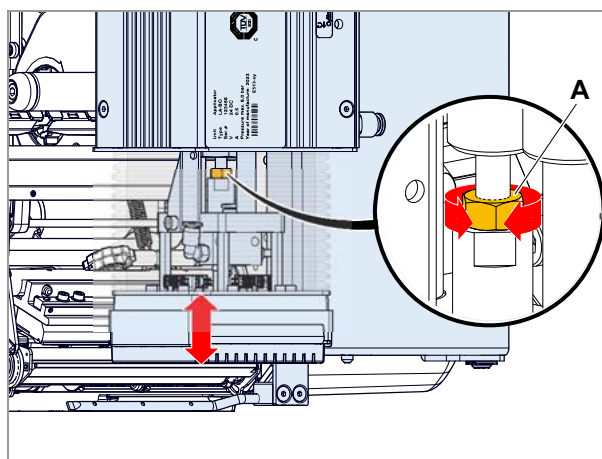

[18] Setting the upper limit.

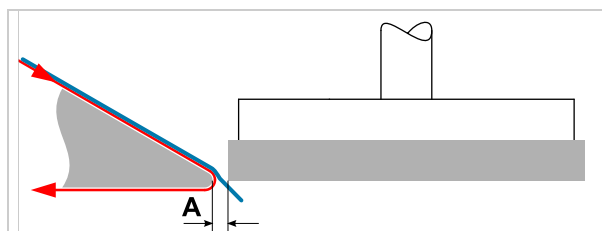

[19] Label path between dispensing edge and pressure plate.

Operation

ACTIVATING/DEACTIVATING THE APPLICATOR

Activating

In *normal operation* mode, the applicator is supplied with compressed air by the plant in which it is integrated.

1. (If the rotary knob of the on-off valve is secured with a padlock) Open the lock and remove it.
2. Turn the rotary knob of the on-off valve on the service unit counterclockwise as far as it will go (90°):

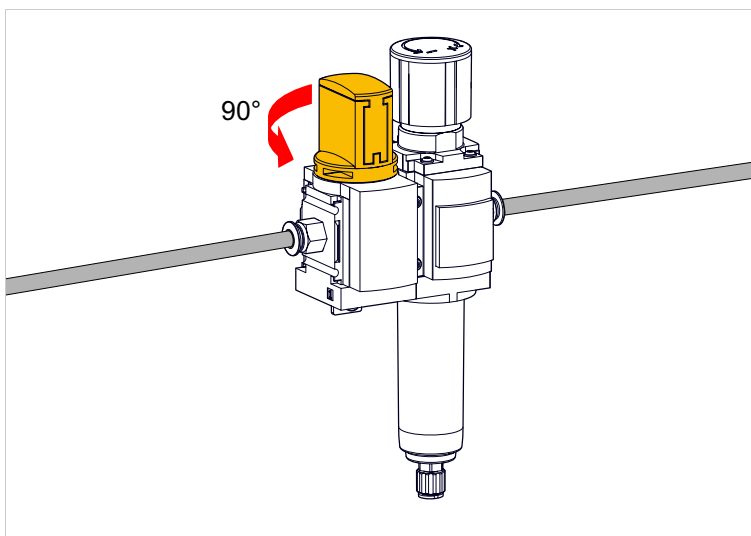

[20] Side of the on-off valve in „Open“ position (B).

After switching on the compressed air supply, the pressure plate starts moving to the top into home position. The apply-cycle starts as soon as the following conditions are fulfilled:

- Pressure plate is in home position
- Control signals are active (print & apply system or labeler is online)
- Interlock circuit is closed (protection door is closed)

Deactivating

CAUTION!

After switching off the compressed air supply, the pressure plate of the applicator moves down into end position. Hazard of damage to the applicator by products passing by.

- Stop the conveyor *or*
- Make sure that no products pass by *or*
- Fix the applicator pressure plate in home position

1. Stop the machine, to which the applicator is attached.
2. Switch off the compressed air supply (using an appropriate switch at the plant or the manual on-off valve at the service unit).

After switching off the compressed air supply, the pressure plate of the applicator moves down into end position.

EXCHANGING THE PRESSURE PLATE

LTP

The pressure plate on the LTP must be replaced if the foam material is worn out and the applicator no longer presses the label on the entire surface.

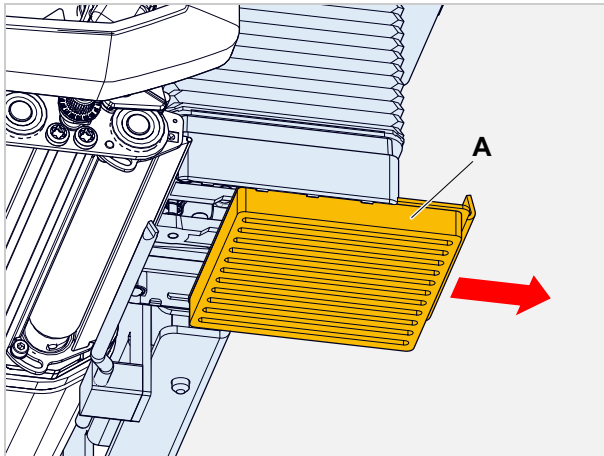

[21] Pulling out the pressure plate (LTP).

→ Pull out the pressure plate [20A] to the side and replace it by a new one.

LTPV

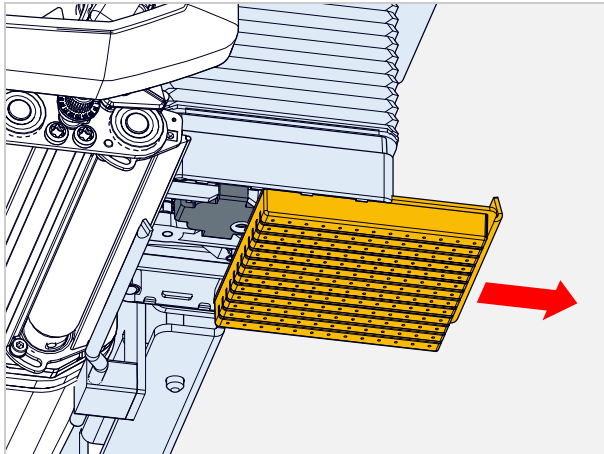

[22] Pulling out the pressure plate (LTPV).

On the LTPV, the pressure plate must be individually adapted to the label size used. (see chapter **Punching the Vacuum Applicator Plate (LTPV)** □ on page 29).

▣ An extra pressure plate is required for each label size. When changing the label size, only the plate has to be changed, which is done in a few simple steps [22].

VALVES SETTING



WARNING!

Danger of cuts and crush injuries between moveable pressure plate and dispensing edge.

For this reason pay attention to the following when triggering the applicator for test or setup purposes...

- keep a sufficient distance.
- don't touch the applicator.

Butterfly valves

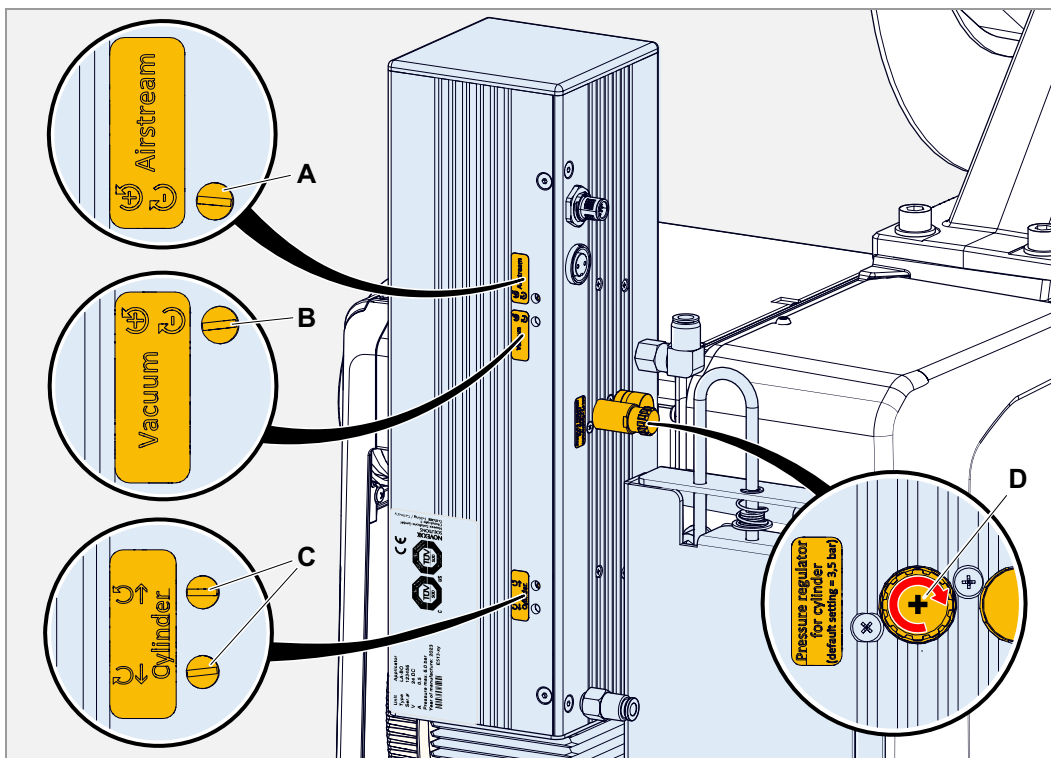

[23] Compressed air settings at the LTPV.

The following applies to the screwdriver settings (A-C):

- Counterclockwise rotation: „+“ (more air flows through the valve)
- Clockwise rotation: „-“ (less air flows through the valve)

A Set the strength of the *support air stream* from beneath the dispensing edge.

B (LTPV) Controls the *strength of the supporting air jet* from below the dispensing edge.

C Controls the *upward/downward speed* of the pneumatic cylinder.

▮▮▮ If the downward speed is too high, the touchdown mechanism of the applicator plate may hit through (audible as a clacking sound, when the applicator reaches its bottom end position). In this case, reduce the downward speed.

D *Pressure regulator* for the pneumatic cylinder. The pneumatic pressure is a measure for the applying force. Set the regulator to 3-4 bars. The minimum pressure is 2.5 bars!

▮▮▮ Adjust the pressure from below - that is, first set a low value and then increase it to the required setting.

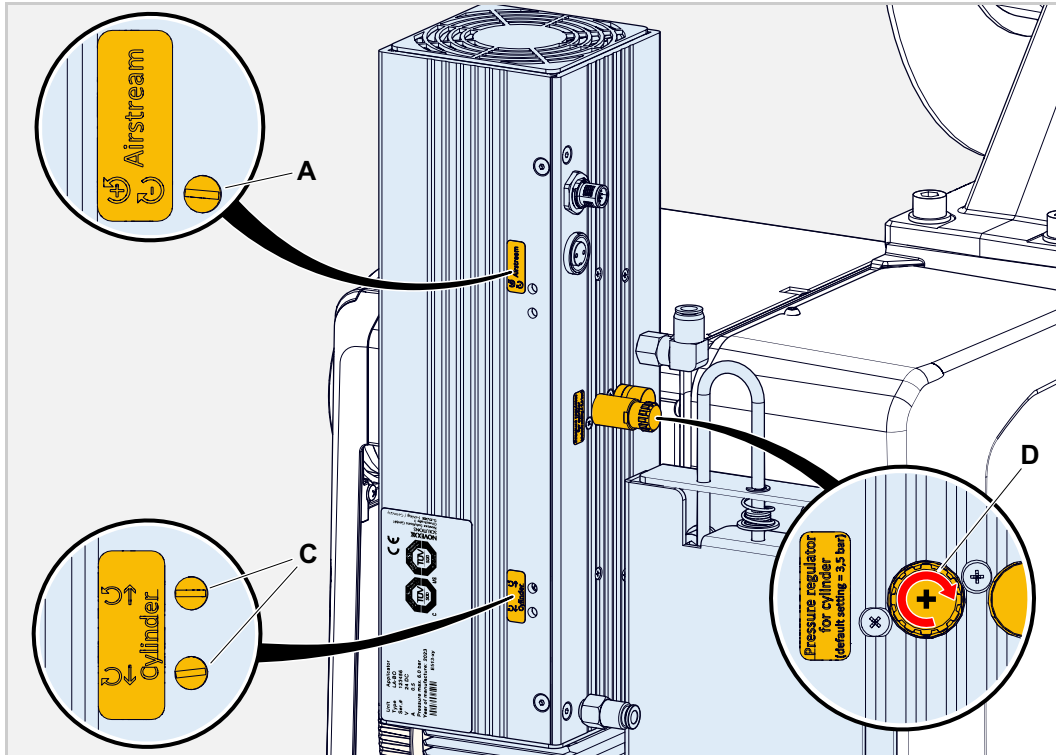

[24] Compressed air settings at the LTP.

Setting the vacuum at the pressure plate (LTPV)

The suction strength at the pressure plate can be set with set screw [28A]. The standard setting is „maximum suction“.

- ▣ Labels with a very smooth surface may require a slightly reduced suction. Otherwise, the labels will not slide onto the suction plate very well.
- ▣ The hole can also be found on LTP type applicators, but there is no valve behind!

Setting the support air

The strength of the support air can be set with set screw [28B].

Checking the transfer process

The schematics to the right display the typical transfer process: from dispensing the label to transferring the label to the product.

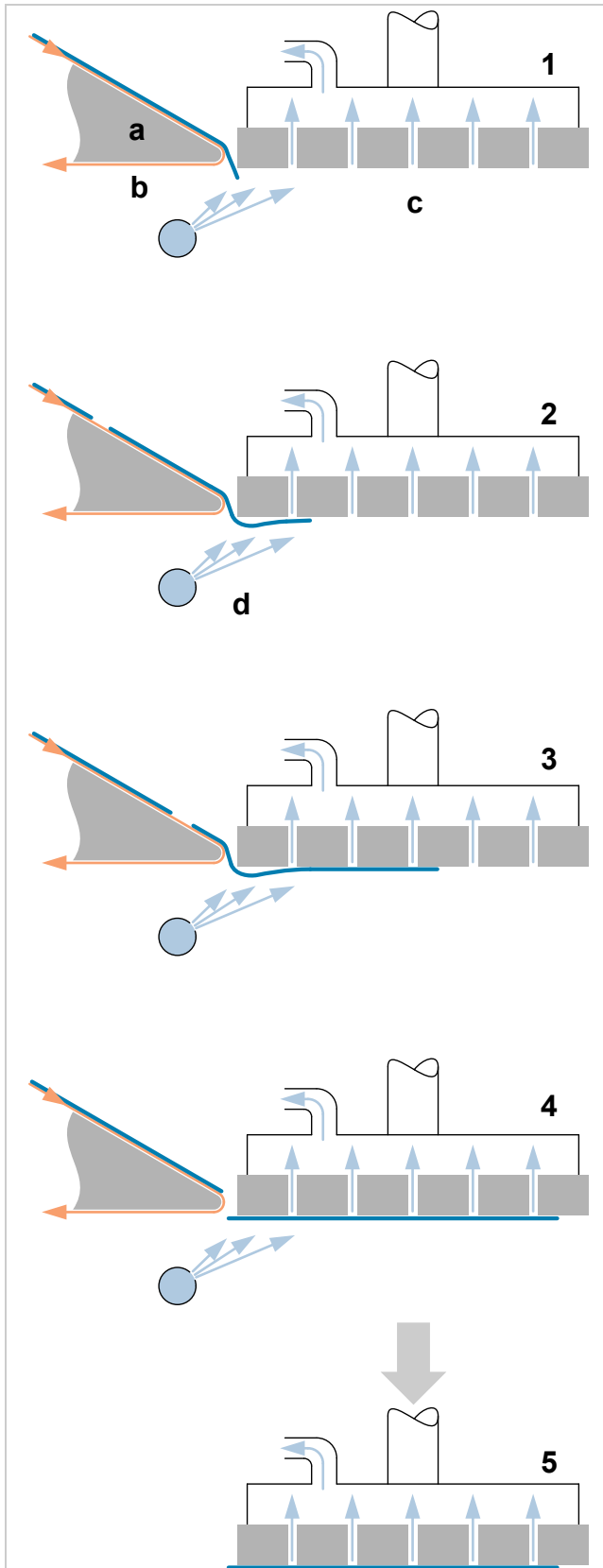



[25] Schematic of transfer process

1. Once a print or dispensing command is received, the label is transferred across the dispensing edge [25a] and separated from the release paper [25b]. The label is transferred closely past the edge of the vacuum plate [25c].

The amount of bending in the label depends on the following factors:

- Feed speed
- Adhesive force
- Label thickness
- Room temperature

If the label is not deflected far enough to come past the vacuum plate, adjust the height setting of the dispensing edge. See chapter [Setting the distance to the dispensing edge](#)  on page 29.

2. The support air [25d] deflects the label away from the vacuum plate.
For more information, see chapter [Setting the vacuum at the pressure plate \(LTPV\)](#)  on page 34.
3. The label is 'caught' by the vacuum plate and moved along by the feed force. The suction force of the vacuum plate must not exceed the feed force for the label. Here, it is important to consider the interaction between feed force, support air angle, support air force and suction force.
For more information, see chapter [Setting the support air](#)  on page 34.
4. Once the label has separated completely from the dispensing edge, it snaps onto the vacuum plate.
The distance to the dispensing edge prevents the label from adhering during the downwards movement of the vacuum plate towards the final position.
5. The vacuum plate is pushed downwards to the final position and the label is transferred onto the product.

CLEANING

Safety



WARNING!

Dangerous situations may arise during maintenance and cleaning work. Accidents may occur due to mechanical or electrical effects if the relevant safety instructions are not observed!

- Switch off the machine before cleaning or maintenance and completely disconnect it from the main power supply. Depending on the machine type, it may be necessary to pull out the mains power connecting line (refer to the user manual of the machine)!
- Never allow liquid to get into the machine!
- Do not spray the machine with spray bottles or sprays! Use a cloth wetted with cleaning agent!
- Repairs to the machine must only be made by trained service technicians!

Cleaning interval

→ Clean the machine regularly.

The frequency depends on the following factors:

- Operating conditions
- Daily operating duration

Cleaning instructions

CAUTION!

Using sharp cleaning materials may cause damage.

- Do not use any cleaning agents or materials that could damage or destroy the paint finish, labelling, type plates, electrical component, etc.
- Do not use any scouring cleaning agents or any cleaning agents that could dissolve plastic.
- Do not use acid or alkaline solutions.

Cleaning agents:

- Compressed air, vacuum cleaner (if available)
- White spirit (ethanol) or isopropyl alcohol

Proceeding:

- Blow away or suck off any dust and abrasive particles with compressed air or a vacuum cleaner (if any of the two is available)
- Moisten a cloth with white spirit and wipe the machine with it.

FAULT CORRECTION

Status

In the event of faults occurring on the machine, evaluate the status reports of the dispenser/print-dispenser before doing anything.

Read the user manual of the dispenser/print-dispenser, topic section „Status Reports“ or „Operational failures“.

Call service

If you are not authorised to carry out diagnosis and fault correction work, call your technician or the authorised service. The appropriate documentation and spare parts are available to the service personnel in order to carry out repair work of a sufficient quality.

Appendix

PNEUMATIC DIAGRAMS

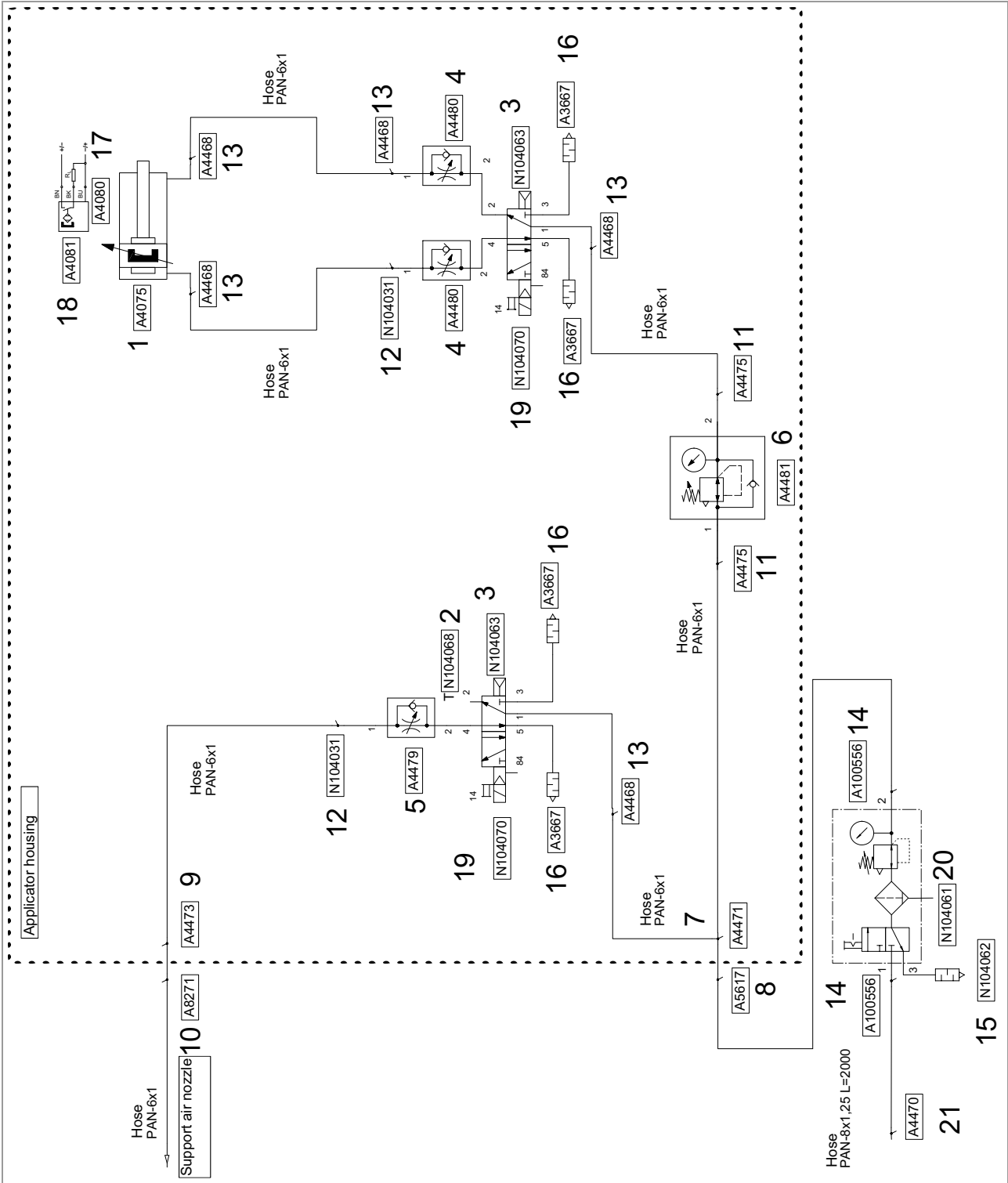

[26] LTP pneumatic diagram.

Pos. no.	Article no.	Amount	Designation
1	A4075	1	Norm cylinder
2	N104068	1	Blanking plug
3	N104063	2	Solenoid valve
4	A4480	2	One-way flow control valve
5	A4479	1	One-way flow control valve
6	A4481	1	Pressure regulator
7	A4471	1	Push-in Y-fitting
8	A5617	1	Push-in L-fitting
9	A4473	1	Push-in L-fitting
10	A8271	1	Push-in fitting
11	A4475	2	Push-in L-connector
12	N104031	2	Push-in fitting
13	A4468	5	Push-in L-fitting
14	A100556	2	Push-in fitting
15	N104062	1	Silencer
16	A3667	4	Silencer
17	A4080	1	Mounting kit
18	A4081	1	Proximity switch
19	N104070	2	Electrical sub-base
20	N104061	1	Service unit combination
21	A4470	1	Quick coupling plug

[Tab. 4] Parts list for pneumatic plan LTP.

Pos. no.	Article no.	Amount	Designation
1	A4075	1	Norm cylinder
2	N104064	1	Solenoid valve
3	N104063	1	Solenoid valve
4	A4480	2	One-way flow control valve
5	A4479	2	One-way flow control valve
6	A4481	1	Pressure regulator
7	A4471	1	Push-in Y-fitting
8	A5617	1	Push-in L-fitting
9	A4473	1	Push-in L-fitting
10	A8271	1	Push-in fitting
11	A4475	2	Push-in L-connector
12	N104031	2	Push-in fitting
13	A4468	5	Push-in L-fitting
14	A100556	2	Push-in fitting
15	N104062	1	Silencer
16	A3656	1	Vacuum generator
17	A4080	1	Mounting kit
18	A4081	1	Proximity switch
19	N104070	3	Electrical sub-base
20	N104061	1	Service unit combination
21	A3658	3	Push-in fitting
22	A3657	1	Push-in L-fitting
23	A4470	1	Quick coupling plug
24	A3667	5	Silencer

[Tab. 5] Parts list for pneumatic plan LTPV

EU Declaration of Incorporation

(Translation of original version)

We, Novexx Solutions GmbH
Ohmstraße 3
D-85386 Eching
Germany

hereby declare that the partly completed machine designated below has been designed and built in such a way as to be in conformity with the safety and health protection requirements of directive 2006/42/EC, annex I, which are marked „fulfilled“ in the following table „Appendix regarding the Declaration of Incorporation“.

The special technical documents in accordance with appendix VII part B of directive 2006/42/EC have been created. We undertake to forward the special technical documentation in respect of the partly completed machine to national authorities at their request. We shall submit them by means of electronic data carrier.

The partly completed machine designated herein is furthermore in compliance with the provisions of directive 2014/30/EU (EMC) and directive 2011/65/EU (RoHS, in the currently valid version).

The designated partly completed machine must not be placed in operation until it has been determined that the machine in which the partly completed machine has been installed is in compliance with the provisions of directive 2006/42/EG.

Models	LA-TO / LA-TO XL LA-TO touch down / LA-TOXL touch down LA-TO BO / LA-TO BO XL LTP / LTPV LA-SO LTSI LTSA
General designation	Applicator
Applicable EU directive	2006/42/EG (Machinery) 2014/30/EU (EMC) 2011/65/EU (RoHS)
Applied harmonized standards, especially	EN ISO 12100 : 2010 EN ISO 4414 : 2010 EN 60950-1/A2 : 2013
The person authorized to compile technical documents	Novexx Solutions GmbH (for address see above)

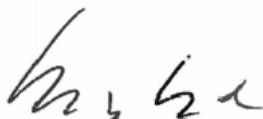

Eching, 18.6.2018

Manfred Borbe (Operations Director)

APPENDIX REGARDING THE DECLARATION OF INCORPORATION

List of the essential health and safety requirements applied and fulfilled for the product named in the declaration of incorporation, relating to the design and construction of machinery.

Number Annex I	Designation	Not applicable	Fulfilled	Remark
1.1	General remarks			
1.1.2.	Principles of safety integration		X	
1.1.3.	Materials and products		X	
1.1.4.	Lighting	X		
1.1.5.	Design of machinery to facilitate its handling		X	
1.1.6.	Ergonomics	X		
1.1.7.	Operating positions	X		
1.1.8.	Seating	X		
1.2.	Control systems			
1.2.1.	Safety and reliability of control systems	X		
1.2.2.	Control devices	X		
1.2.3.	Starting	X		
1.2.4.	Stopping			
1.2.4.1.	Normal stop	X		
1.2.4.2.	Operational stop	X		
1.2.4.3.	Emergency stop	X		
1.2.4.4.	Assembly of machinery	X		
1.2.5.	Selection of control or operating modes	X		
1.2.6.	Failure of the power supply		X	
1.3.	Protection against mechanical hazards			
1.3.1.	Risk of loss of stability	X		
1.3.2.	Risk of break-up during operation		X	
1.3.3.	Risks due to falling or ejected objects	X		
1.3.4.	Risks due to surfaces, edges or angles		X	
1.3.5.	Risks related to combined machinery	X		
1.3.6.	Risks related to variations in operating conditions	X		
1.3.7.	Risks related to moving parts			Requires protective device ^a
1.3.8.	Choice of protection against risks arising from moving parts			
1.3.8.1.	Moving transmission parts	X		
1.3.8.2.	Moving parts involved in the process			Requires protective device ^a
1.3.9.	Risks of uncontrolled movements	X		
1.4.	Required characteristics of guards and protective devices			
1.4.1.	General requirements			^a
1.4.2.	Special requirements for guards			
1.4.2.1.	Fixed guards	X		
1.4.2.2.	Interlocking movable guards			^a
1.4.2.3.	Adjustable guards restricting access	X		
1.4.3.	Special requirements for protective devices	X		
1.5.	Risks due to other hazards			
1.5.1.	Electricity supply		X	
1.5.2.	Static electricity		X	

Number Annex I	Designation	Not applicable	Fulfilled	Remark
1.5.3.	Energy supply other than electricity		X	
1.5.4.	Errors of fitting		X	
1.5.5.	Extreme temperatures		X	
1.5.6.	Fire		X	
1.5.7.	Explosion	X		
1.5.8.	Noise		X	
1.5.9.	Vibrations	X		
1.5.10.	Radiation		X	
1.5.11.	External radiation		X	
1.5.12.	Laser radiation	X		
1.5.13.	Emissions of hazardous materials and substances	X		
1.5.14.	Risk of being trapped in a machine	X		
1.5.15.	Risk of slipping, tripping or falling	X		
1.5.16.	Lightning	X		
1.6.	Maintenance			
1.6.1.	Machinery maintenance		X	
1.6.2.	Access to operating positions and servicing points		X	
1.6.3.	Isolation of energy sources		X	
1.6.4.	Operator intervention		X	
1.6.5.	Cleaning of internal parts	X		
1.7.	Information			
1.7.1.	Information and warnings on the machinery		X	
1.7.1.1.	Information and information devices	X		
1.7.1.2.	Warning devices	X		
1.7.2.	Warning or residual risks		X	
1.7.3.	Marking of machinery		X	
1.7.4.	Instructions		X	
1.7.4.1.	General principles for the drafting of instructions		X	
1.7.4.2.	Contents of the instructions		X	
1.7.4.3.	Sales literature		X	

a) Installation by the system integrator

Novexx Solutions GmbH
Ohmstraße 3
85386 Eching
Germany
☎ +49-8165-925-0
www.novexx.com

NOVEXX 
SOLUTIONS