

# USER MANUAL

## WAC

Wrap around conveyor

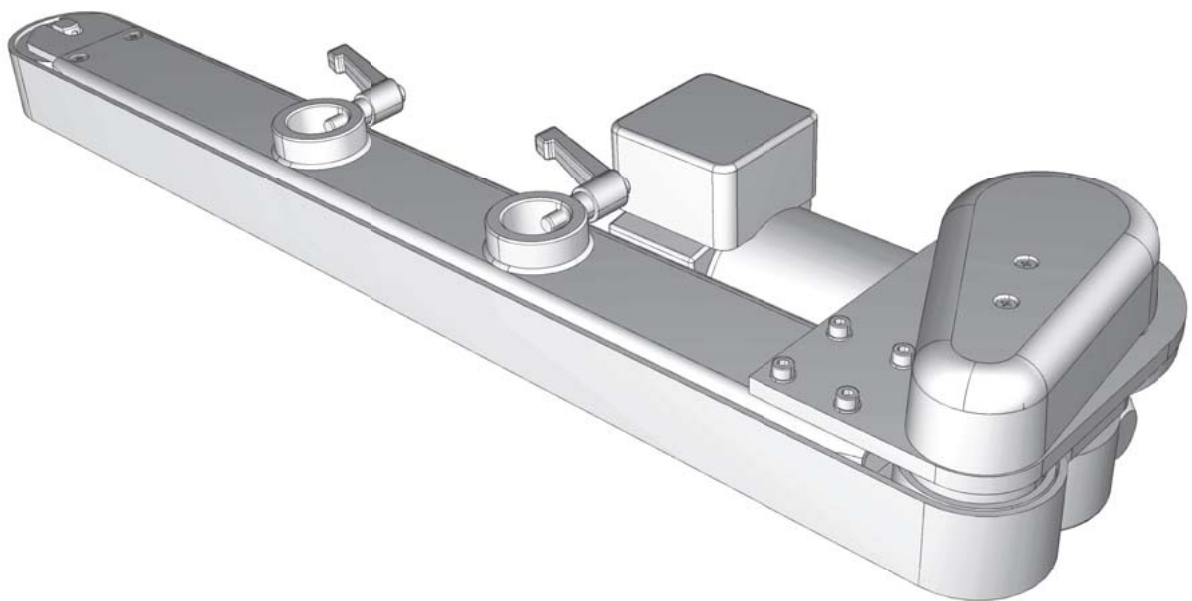



## Contents

### Please note -5

General Information -5

Validity of this manual and required compliance -5

How information is represented -6

For your safety -7

Intended use -7

Information and qualification -7

Operating safety of the machine -9

Every time before starting production -11

Warning symbols on the machine -12

### Product Description -13

Technical Data -13

Dimensions -13

Performance Data -14

Electrical connection -14

Ambient conditions -14

Certificates -15

Overview -16

Designs of wrap around conveyor -16

Functionality -17

Switching on/off -19

### Commissioning -20

Safety -20

Installation -21

Install the motor -21

Installing the wrap around conveyor -22

Connection -24

Setting the belt speed -24

### Cleaning & Maintenance -25

Cleaning instructions -25

Safety -25

Cleaning agent -25

Cleaning interval -25

Maintenance -26

Maintenance instructions -26

Adjust/change belt -27



# Please note

## GENERAL INFORMATION

### Validity of this manual and required compliance

#### Description of the device

WAC Wrap Around Conveyor

#### Contents

This operating manual refers exclusively to the machine types listed above. It is intended to help in proper installation, operation and adjustment of the machine.

For information about the required qualification: See chapter [Information and qualification](#) on page 7.

For technical questions that are not addressed in this operating manual, please contact the manufacturer, NOVEXX Solutions.

#### Liability

NOVEXX Solutions reserves the right:

- To make changes in design and components, and to use equivalent other parts than those specified in line with technological progress.
- To change information in this manual.

Any obligation to extend these changes to machines previously delivered is excluded.

#### Copyright

NOVEXX Solutions retains all rights to this manual and its appendices. Reproduction, reprint or any other type of duplication, including parts of the manual, are permitted only with written approval.

Printed in Germany

#### Manufacturer

Novexx Solutions GmbH

Ohmstrasse 3

D-85386 Eching, Germany

Tel.: +49-8165-925-0

Fax: +49-8165-925-231

[www.novexx.com](http://www.novexx.com)

## How information is represented

### Explanation of symbols

To enhance readability and make information easier to find, different types of information are identified:

- Instruction with no order of tasks assigned
- 1. Numbered instructions introduced by preceding text
- 2. The specified order must be followed!
- ▮→ Special note for action that must be performed!
  - Enumeration of features
  - Other feature



The Experts symbol identifies activities that are reserved exclusively for qualified and specially trained personnel.



The information symbol identifies notes and recommendations as well as additional information.

### Notes about hazards and risks

Important instructions that must absolutely be followed are specially highlighted:



#### WARNING!

A warning symbol refers to risks that can result in severe or fatal injuries! The note contains safety measures to protect affected persons.

→ Instructions must be followed without exception.

#### CAUTION!

A caution symbol refers to risks that can result in property damage or personal injury (minor injuries). The note contains instructions for preventing damage.

→ Instructions must be followed without exception.

### Illustrations

Illustrations appear in the text where required. References to these illustrations are shown in [square brackets] containing the number of the illustrations. Uppercase letters after an illustration number, for example [12A], refer to the corresponding item within the illustration.

## FOR YOUR SAFETY

### Intended use

**WARNING!**

Risk of injury due to missing protective equipment.

The wrap around conveyor described here is an “incomplete machine” as defined in the Machinery Directive 2006/42/EC!

→ Put the wrap around conveyor into operation only when you have ascertained that the machine into which the wrap around conveyor is to be installed satisfies the requirements of the Machinery Directive, Annex IIA.



Although the wrap around conveyor is an “incomplete machine” in the sense of the Machinery Directive, it is referred to in this operating manual as “machine” or “wrap around conveyor” for reasons of comprehensibility.

The wrap around conveyor is an electrically driven belt conveyor system for industrial applications. It is intended for rotating cylindrical products, e.g. bottle or cans, around their own vertical axis during transport on a belt conveyor in order to press a previously selectively dispensed label onto the round surface of the product. The wrap around conveyor is installed on the side of the belt conveyor for this. A counter-holding plate or a second wrap around conveyor must be installed on the opposite side to generate the rotational movement.

When using a counter-holding plate, the wrap around conveyor is generally operated at two to two and a half times the speed of the belt conveyor to prevent the products from falling over on entering and leaving the working area of the wrap around conveyor.

The motor requires the use of an electronic motor controller. Here, the speed can be varied continuously. The power supply and control must be provided by an external controller supplied by the operating company. NOVEXX Solutions offers switch cabinets for the control of complete belt units.

Any other type of or more extensive application will be considered non-intended use.

NOVEXX Solutions shall assume no liability for damage resulting from non-intended use of the machine.

## Information and qualification

### Ensuring the necessary qualification

- Only fully trained and authorised personnel are permitted to install, connect, operate, adjust and maintain the machine.
- Service work must only be performed by qualified and appropriately trained technical specialists (service technicians) or the customer service department.
- Areas of responsibilities for operating and servicing the machine must be clearly defined and consistently observed.
- Personnel must also be regularly instructed in on-the-job safety and environmental protection.

**Qualification for operation**

The instruction provided for the operating personnel must ensure:

- that the operating personnel can use the machine independently and without danger.
- that the operating personnel can rectify minor operating faults independently.

→ At least 2 persons should be instructed in operation.

**Qualification for system integrators and service technicians**



Installation of the machine and service work on the machine require appropriate qualification. Only service personnel with technical training are able to assess the tasks to be performed and recognise potential dangers.

- Knowledge acquired through technical training in mechanics and electronics (for example in Germany the training to become a mechatronics engineer).
- Participation in a technical training course for the corresponding machine offered by the manufacturer.
- The service personnel must be acquainted with the function of the machine.
- The system integrator must be acquainted with the functionality of the system into which the machine is being integrated.

Tasks	System integrator	Operator	Service technician
Install the machine	X		
Connection	X		
Adjust	X		
Switching on/off	X	X	X
Application-related settings	X	X	X
Rectify minor operating faults	X	X	X
Clean the machine		X	X
Rectify major operating faults			X
Settings to the electronics/ mechanics			X
Repairs			X

[Tab. 1] An example of the distribution of tasks among different qualified personnel.

**Making note of information**



**WARNING!**

The machine can only be operated safely and efficiently if all the necessary information is observed!

- Before beginning operation, read this operating manual and follow all of the instructions.
- Observe all additional safety and warning information given on the machine.
- Allow only technically qualified persons to operate and adjust the machine.

Any product liability and warranty claims will not be valid unless the machine is operated according to the instructions in the operating manual.



**Keeping information available**

This operating manual

- must remain readily available for operating personnel at a location near to the machine.
- must be kept in legible condition.
- If the machine is sold, it must be made available to the new owner.
- The safety and warning symbols and messages on the machine must be kept in a clean and legible state. Replace any signs that are damaged or missing.

**Operating safety of the machine****Intended use**

- The machine must only be used in accordance with the specifications in section **Intended use**  on page 9.

**Installation, repair****WARNING!**

Improper use of the machine can result in accidents, property damage and loss of production!

- Inspect the machine closely for visible transport damage during installation. In the event of damage, notify NOVEXX Solutions immediately.
- Do not install the machine in potentially explosive environments.
- Ensure that the belt conveyor on which the wrap around conveyor is installed cannot tip over.
- Install the belt conveyor in such a way that the products do not fall off at the end of the belt.
- Provide a mains isolation system and emergency stop device during installation.
- Install mains isolation system, emergency stop device and operating elements so that they are easily accessible.
- Use a motor controller that switches off the motor in the event of a fault (e.g. blockage).
- Use connecting leads that comply with the regulations of the country in which the machine is being installed.
- Lay the connection cables so that no one can trip over them.
- Check the effectiveness of all safety functions.
- Operate the machine only when it is in a technically flawless condition.
- Put the machine into operation only after at least one successful test run has been carried out.
- Make changes or modifications to the machine only after consultation with the NOVEXX Solutions Customer Service department.
- Use only OEM spare parts.

**WARNING!**

Risk of shearing and crushing between product and wrap around conveyor!

- Prevent access to the machine during operation by installation of higher-level protective equipment <sup>a</sup>.

a) Movable, separating protective device in accordance with EN 953

**After all maintenance and repair work****WARNING!**

Risk of accidents from moving or loose parts!

- Install all covers and protective equipment again.
- Check all bolted connections loosened or removed during work for tightness again.
- Remove all tools and other equipment used for the maintenance or repair work from the working area of the machine.
- Check the effectiveness of all safety functions.

**WARNING!**

Contacting electrically live components can cause lethal electrical shocks and burns!

- After assembly, check the machine according to the applicable regulations of the relevant country<sup>a</sup>.

a) For Germany: DIN VDE 701-702 "Recurrent test and test after repair and modification of electrical equipment"

**Warning of injuries due to electrical shock****WARNING!**

Contacting electrically live components can cause lethal electrical shocks and burns.

- Only operate the machine when the enclosure is properly installed.
- The machine must only be connected by an authorised technician who is acquainted with the associated dangers.
- Switch the machine off before cleaning and servicing.
- Keep the machine dry.
- If a liquid gets into the machine, switch off the machine immediately. Notify a service technician.
- Keep the machine's On/Off switch accessible.
- In case of emergency switch off the machine.

**CAUTION!**

If the supply voltage is too high or too low, the machine may be damaged.

- Operate the machine only at the mains voltage given on the type plate.

**Warning of injury hazards from mechanical components****WARNING!**

Danger of injury due to moving and rapidly rotating parts!

- Maintain a safety clearance from the machine when it is in operation.
- Never reach into a machine that is running.
- Switch off the machine before making any mechanical adjustments.
- Keep clear of the area around moving parts even when the machine is stopped if there is any possibility of the machine starting up.

**WARNING!**

Entanglement hazard!

- Do not wear ties, loose clothing, jewellery, wrist watches or similar objects when working in the vicinity of the running machine, especially when inspecting the belt conveyor.
- Long hair must be kept in a hair net and must not be worn loose.

**WARNING!**

Crushing hazard at the belt due to products on the conveyor equipment!

- Never reach between the product and the belt when the machine is running or ready for operation.
- Never remove or bypass the protective equipment to prevent reaching in while the machine is in operation.

**Every time before starting production****Due diligence of the operator and service personnel**

- Ensure that the following requirements are met in accordance with the details specified in the operating manual:
  - The machine must be set up and configured to meet applicable requirements.
  - All necessary safety equipment must be installed.
  - The machine must have successfully completed at least one test run.
  - The machine must be connected to the energy supply.
- The operating personnel is provided with the necessary personal protective equipment, e.g. hair net. Ensure that the protective equipment is used for its intended purpose.

**Due diligence of the operating personnel**

- Check the safety equipment to ensure it is working correctly.
- Check the machine for visible damage. Report defects that are discovered immediately.
- Use personal protective equipment properly, for example wearing a hair net.
- Remove material and objects that are not required from the working area of the machine.
- Ensure that only authorised persons remain in the working area of the machine.
- Ensure that no one can be endangered by the machine starting up.
- Ensure that the emergency stop device is freely accessible.

### Warning symbols on the machine

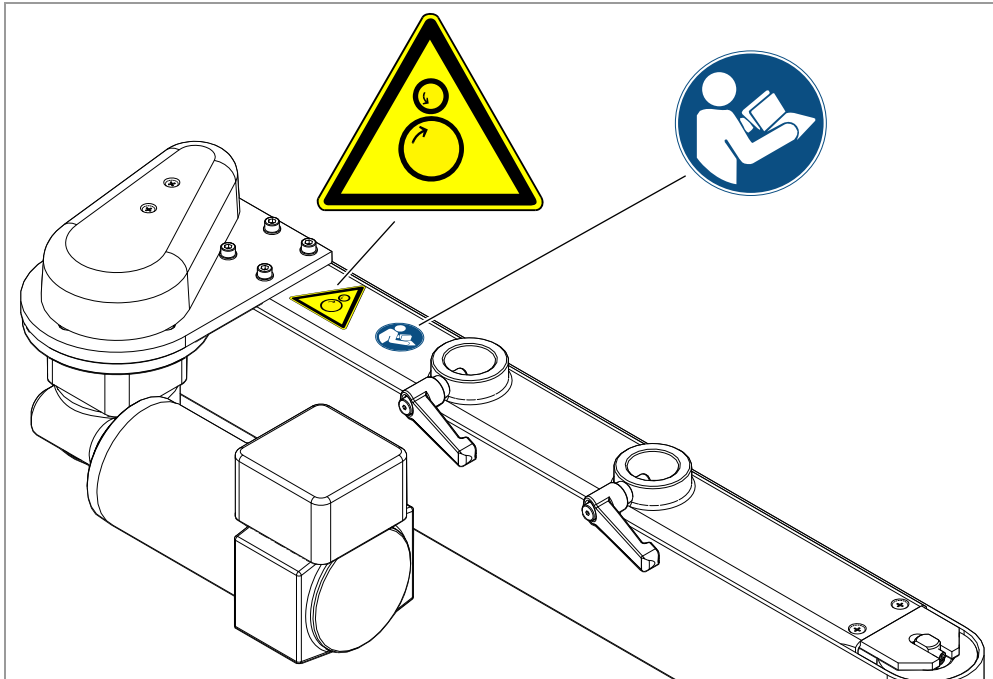

[1] Warning symbols on the wrap around conveyor





**CAUTION!**

Warning symbols on the machine provide important information for the operating personnel.

- Do not remove warning symbols.
- Replace missing or illegible warning symbols.

Meaning of the warning symbols:

Warning symbol	Meaning	Order No.
	The warning symbol "Entanglement hazard" warns of dangerous movements of the machine that could lead to entanglement.	A5346
	This symbol prompts you to read and observe the operating manual.	A5331

[Tab. 2] Meaning of the warning symbols

# Product Description

## TECHNICAL DATA

### Dimensions

#### Dimensions

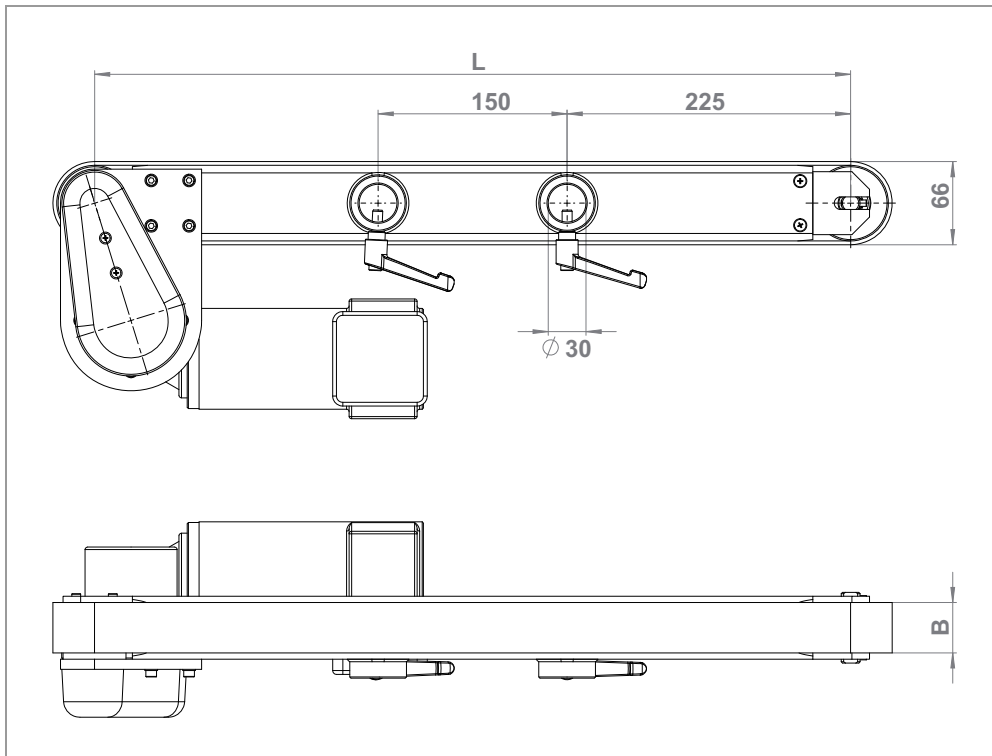

[2] Dimensions on the wrap around conveyor.

- L = 300 mm or 600 mm (for 300 mm, only one clamp with diameter 30 mm)
- B = 45 mm, 95 mm, 150 mm or 200 mm

#### Weight

Design (B x L in mm)	Weight in kg
45 x 300	7.5
45 x 600	9.5
95 x 300	9.6
95 x 600	12
150 x 300	11.4
150 x 600	12.4

## Performance Data

### Belt speed

max. 35m/min

### Product weight

The total weight of all products on the belt conveyor <sup>1</sup> must not exceed 10 kg.

### Motor data

- Speed: max. 120rpm
- Torque: max. 10Nm

## Electrical connection

### Mains voltage

180 V DC

### Nominal current

1.4 A (current limited by controller installed by operating company)

### Nominal output

0.2kW

### Connection

Switch cabinet with power supply and control modules necessary.



A Lenze 532 electronic motor controller together with electric switches, emergency stop switches, fuses and interference suppression filters is required for operation of the hold down conveyor.

## Ambient conditions

### Installation location

- Inside buildings
- Protected from water and wind
- Dry
- Non-explosive atmosphere

### Operating temperature

+5 to +40°C

### Storage temperature

0 to +70°C

### Relative humidity

30 to 80% RH (non-condensing)

---

1) NOVEXX Solutions belt conveyor (B-Conveyor) or chain belt conveyor (CB-Conveyor)

### **Noise emissions**

< 70dB(A)

### **Certificates**

CE, TÜV mark, GOST

Standard DIN EN 55022 stipulates the following instruction text for class A machines:

"WARNING! This is class A equipment. This equipment may cause wireless interference in residential areas. If it does the operator may be required to take appropriate measures."

## OVERVIEW

### Designs of wrap around conveyor

#### Designs

The wrap around conveyor is available in the following sizes:

- wrap around conveyor WAC 45 x 300 mm
- wrap around conveyor WAC 45 x 600 mm
- wrap around conveyor WAC 95 x 300 mm
- wrap around conveyor WAC 95 x 600 mm
- wrap around conveyor WAC 150 x 300 mm
- wrap around conveyor WAC 150 x 600 mm
- wrap around conveyor WAC 200 x 300 mm (available on request)
- wrap around conveyor WAC 200 x 600mm (available on request)

▣▣▣ The dimensions given indicate the approximate useful area of the belt (belt width x belt length).

The roll-on belts are optionally available without motor.

The wrap around conveyor is available with two different coatings (please indicate at the time of order):

- Vulkollan coating: The standard coating for most products.
- Porol coating: Extra-soft coating for very delicate products.

▣▣▣ We recommend that the wrap around conveyor and counter-holding plate are ordered with the same coating.

The wrap around conveyor is available as a single wrap around conveyor (Type WAC) and as a tandem wrap around conveyor (Type WACTR). The choice of belt to be used depends on the diameter of the products:

- Products with a diameter > 50 mm: Single wrap around conveyor
- Products with a diameter < 50 mm: Double wrap around conveyor



## Accessories

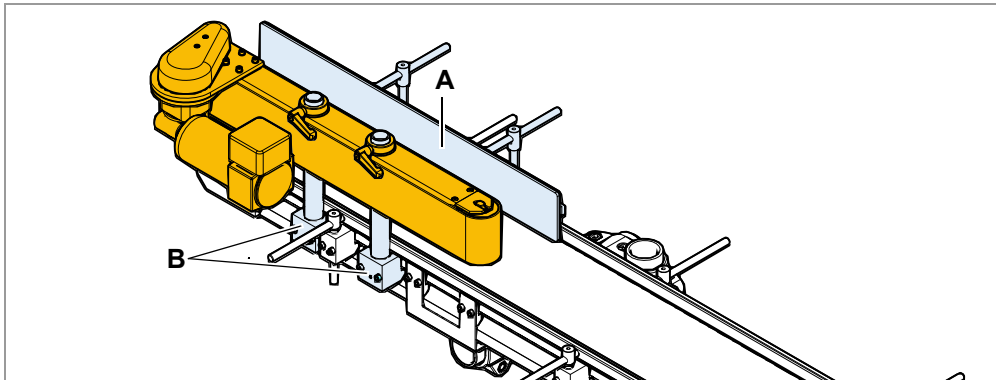

[3] Accessories  
**A** Counter-holding plate  
**B** Holder

A counter-holding plate is generally installed opposite the wrap around conveyor. The counter-holding plate is available with two different coatings (please indicate at the time of order):

- Vulkollan coating: The standard coating for most products.
- Porol coating: Extra-soft coating for very delicate products.

► We recommend that the wrap around conveyor and counter-holding plate are ordered with the same coating.

## Functionality

During the transport of the cylindrical products on the belt conveyor, a typical application comprises the following steps:

1. The product is labelled on the side, whereby the label is adhered to the product only by means of a narrow strip
2. The product contacts the wrap around conveyor and is set in rotation
3. The product is rolled between the wrap around conveyor and counter-holding plate so that the label is wrapped around and pressed against the product

**i** In order to transport the product further at the speed of the belt conveyor, the speed of the wrap around conveyor has to be 2 to 2.5 times that of the belt conveyor.

4. The product leaves the area of the wrap around conveyor and is transported further

The drive consists of a DC brush motor with flange-mounted gearbox, two tooth wheels and a toothed belt that transmits the drive to the hold down conveyor.

The power supply and control must be provided by an external controller supplied by the operating company. NOVEXX Solutions offers switch cabinets for the control of complete belt units.

The hold down conveyor is normally a complementary accessory to the NOVEXX Solutions belt conveyors (B-Conveyors - B for "belt") and chain belt conveyors (CB-Conveyors - CB for "chain belt"). The electronic motor controller is normally housed together with the converter for the belt conveyor drive in a common switch cabinet (NOVEXX Solutions AMC Series).

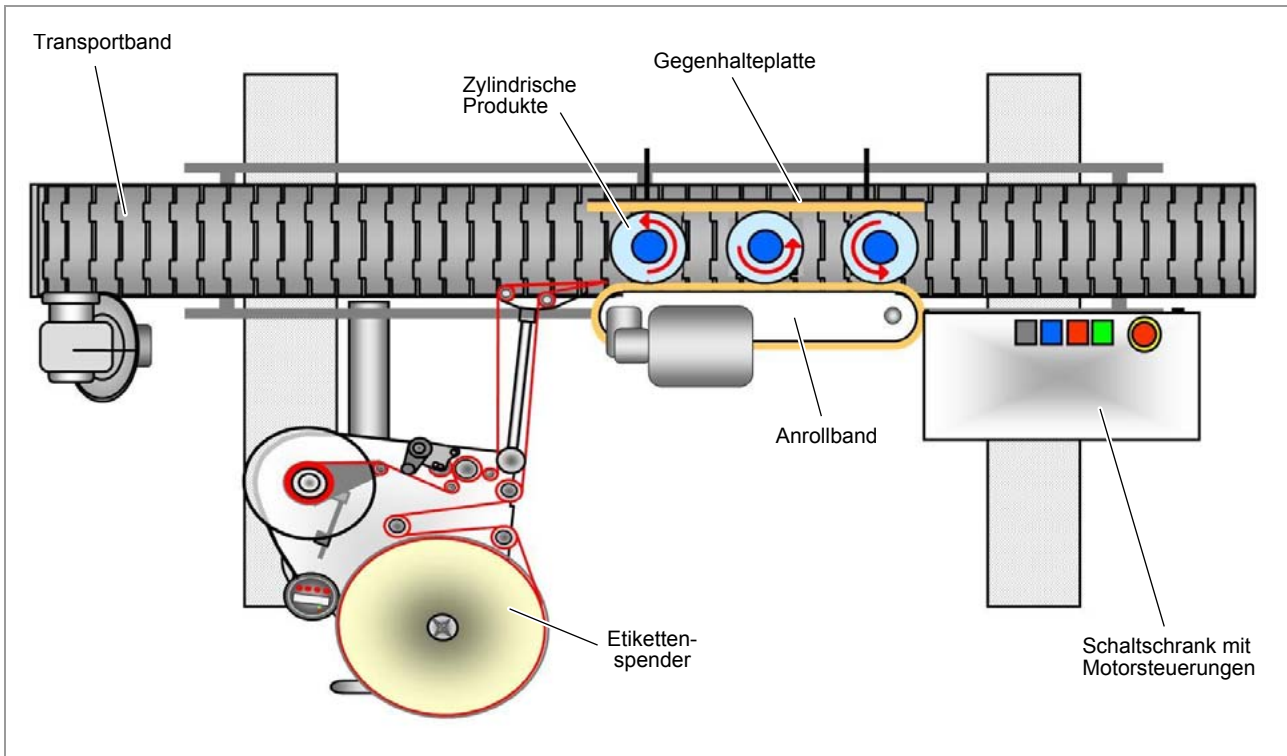

[4] Function of the wrap around conveyor (schematic).

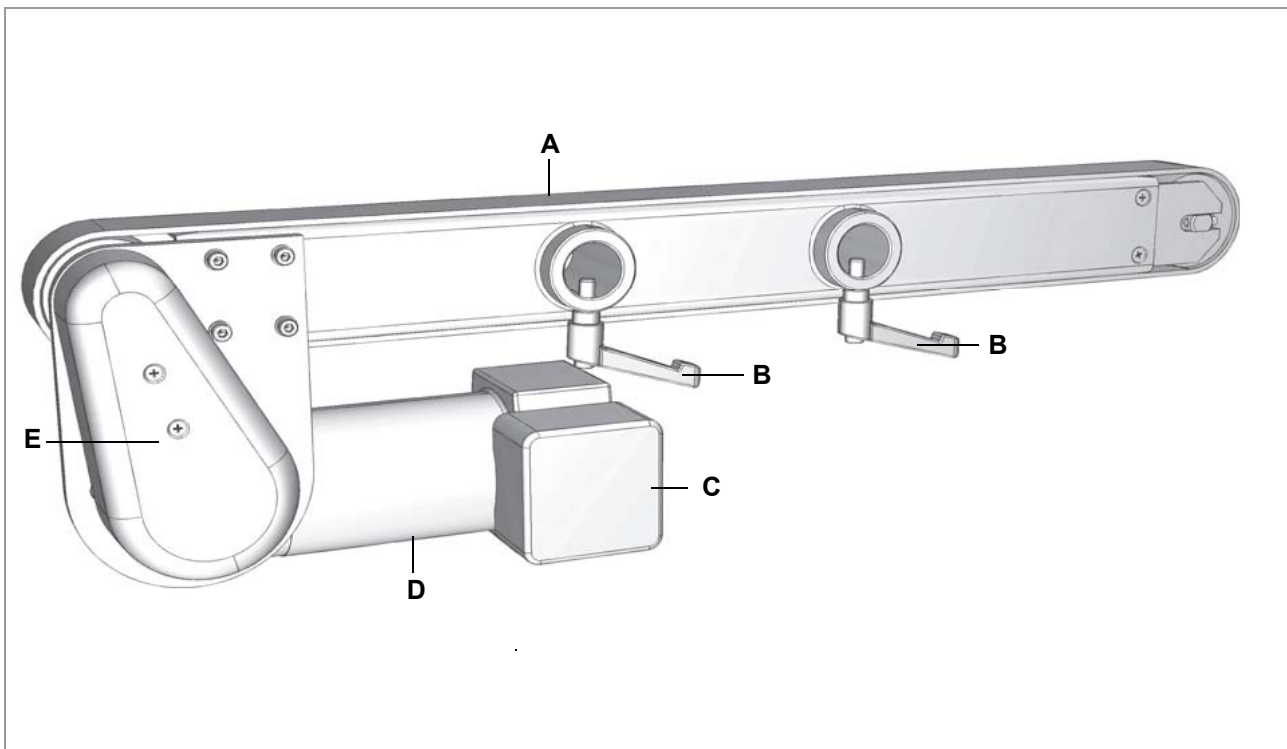

[5] Functional elements of the wrap around conveyor  
**A** wrap around conveyor  
**B** Mounting clamps (for 300 mm wrap around conveyor only one clamp)  
**C** Terminal box for the drive motor  
**D** Drive motor  
**E** Belt drive

## Switching on/off

The ON/OFF switch is installed by the operating company.

The switch is normally located on the switch cabinet of the motor controller [6A].



[6] ON/OFF switch (A) on the switch cabinet of the motor controller (Example: NOVEXX Solutions, AMC Series).

# Commissioning

## SAFETY

The wrap around conveyor may only be installed or serviced by qualified, authorised service personnel, see chapter **Information and qualification**  on page 7.



### WARNING!

Improper use of the machine can result in accidents, property damage and loss of production!

- Inspect the machine closely for visible transport damage during installation. In the event of damage, notify NOVEXX Solutions immediately.
- Do not install the machine in potentially explosive environments.
- Ensure that the belt conveyor on which the wrap around conveyor is installed cannot tip over.
- Install the belt conveyor in such a way that the products do not fall off at the end of the belt.
- Provide a mains isolation system and emergency stop device during installation.
- Install mains isolation system, emergency stop device and operating elements so that they are easily accessible.
- Lay the connection cables so that no one can trip over them.
- Check the effectiveness of all safety functions.
- Operate the machine only when it is in a technically flawless condition.
- Put the machine into operation only after at least one successful test run has been carried out.
- Make changes or modifications to the machine only after consultation with the NOVEXX Solutions Customer Service department.
- Use only OEM spare parts.



### WARNING!

Risk of shearing and crushing between product and wrap around conveyor!

- Prevent access to the machine during operation by installation of higher-level protective equipment <sup>a</sup>.

a) Movable, separating protective device in accordance with EN 953

## INSTALLATION

### Install the motor

If the wrap around conveyor was supplied without motor (option), a motor first has to be installed.

The motor must satisfy the following requirements:

- Torque: max. 10Nm
- Speed: max. 120rpm
- Pitch circle diameter: 80mm
- Shaft diameter<sup>1</sup>: 10<sub>h6</sub>

#### Tools

- Allen key size 5
- Phillips screwdriver, size 2

The following description assumes that the motor supplied ex works is to be installed. If a different motor is used, it is possible that parts of the description do not apply.

#### To perform

1. Grease the motor shaft lightly.
2. Push tooth wheel [8A] onto the motor shaft.
  - ▮ The collar [8B] of the tooth wheel is facing towards the motor.
  - ▮ The chamfer [8C] of the motor shaft must be visible.
  - ▮ Secure the tooth wheel using a parallel key.
3. Secure the tooth wheel with grub screw [8D].
4. Push the motor with tooth wheel through the opening in the flange plate.
5. Fit the toothed belt over both tooth wheels.
6. Bring the motor into position and bolt in place (4 bolts [9A]).
  - ▮ Tightening torque: 10Nm
7. Bolt on cover [10A] (2 bolts).
  - ▮ The toothed belt must not rub against the housing.

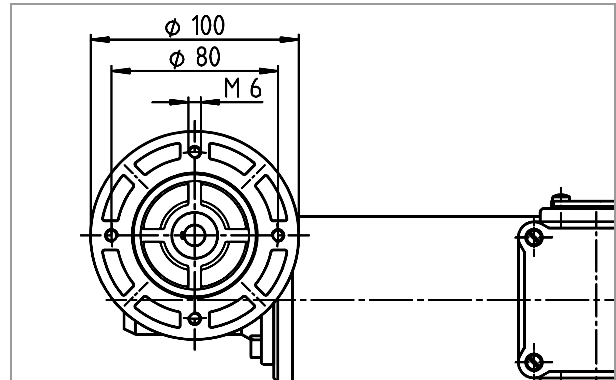

[7] Dimensions of the motor flange.

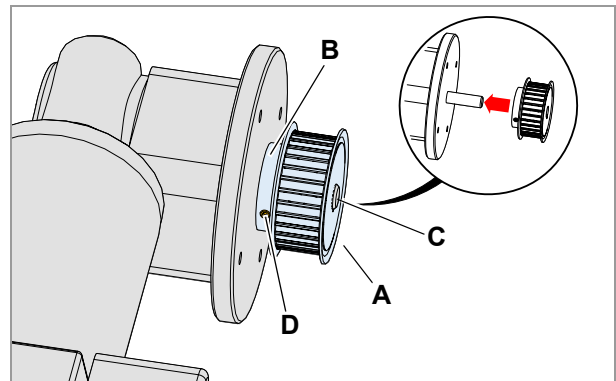

[8] Installation of the tooth wheel supplied.

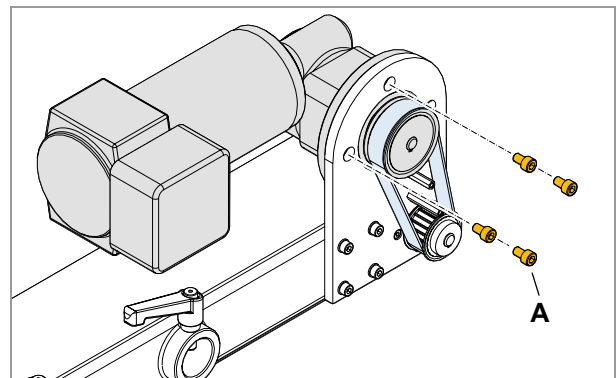

[9] Bolt on the motor.

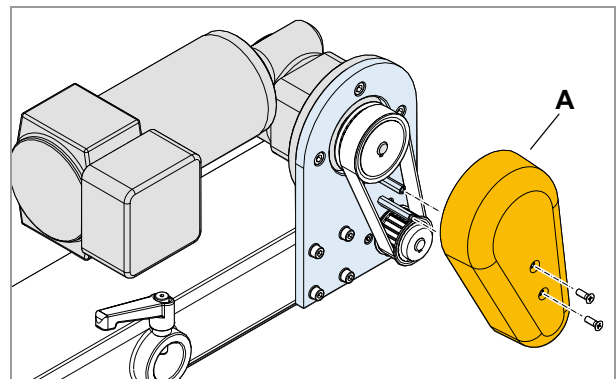

[10] Bolt on the cover.

1) If the tooth wheel supplied is to be used.

## Installing the wrap around conveyor

The wrap around conveyor is normally installed on belt conveyors from NOVEXX Solutions using system components from NOVEXX Solutions.

Depending on its length, the wrap around conveyor is installed with one ( $l = 300\text{mm}$ ) or two ( $l = 600\text{mm}$ ) holders.

### Tools

Allen key size 5

### Assembly

- Hook side holder(s) [11C] into the side profile of the belt conveyor. Tighten the bolts sufficiently that the holder(s) can still be moved.
  - ▮ The slide nuts [12B] of the clamping blocks [12A] must engage in the side profile of the belt conveyor as shown.
- Push the wrap around conveyor onto the holders and align parallel with the belt conveyor. Tighten the clamping lever.
- Tighten the bolts to the following torques:
  - Bolts of the clamping blocks [13B]: 8Nm
  - Clamping lever [13A]: When a resistance is felt, turn the lever by a further 1/8 turn.

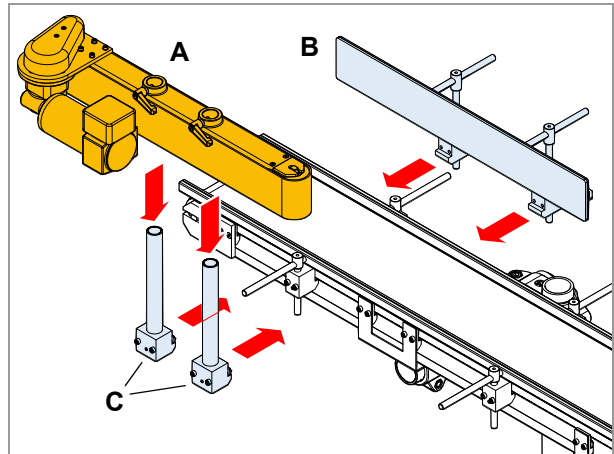

[11] Installation of wrap around conveyor (A) and counter-holding plate (B) on the belt conveyor.

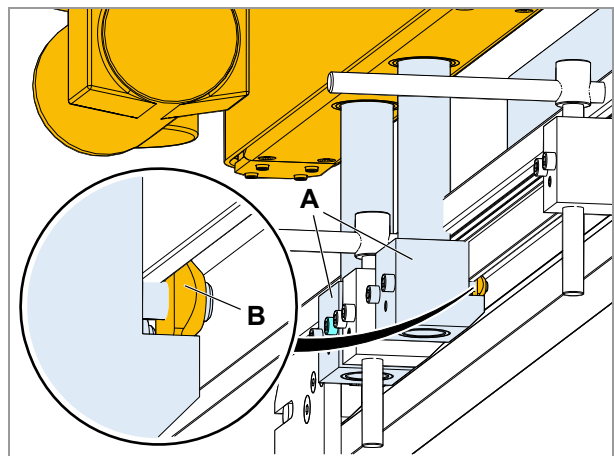

[12] Fasten the clamping blocks (A) to the belt conveyor.

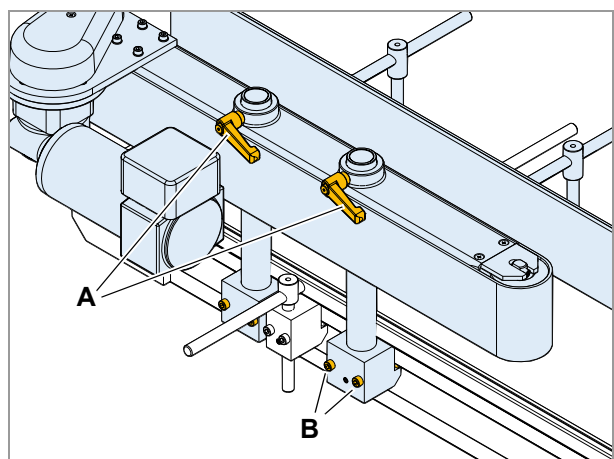

[13] After alignment, tighten the bolts (A, B).

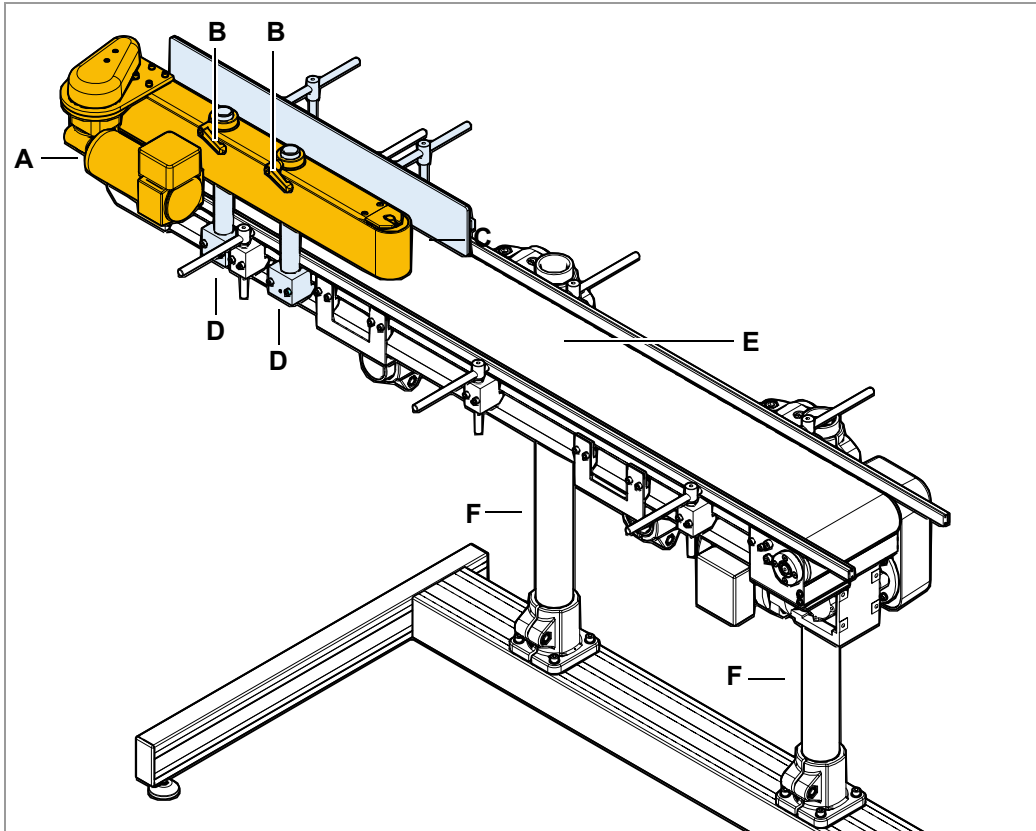

[14] Installation position of the wrap around conveyor

- A wrap around conveyor on the belt conveyor.
- B Clamps for alignment and fixing of the wrap around conveyor on the belt conveyor.
- C Counter-holding plate (accessory).
- D Holder (accessory).
- E Belt conveyor (accessory).
- F Support stand (accessory).

## Connection

**WARNING!**

Contacting electrically live components can cause lethal electrical shocks and burns.

→ The machine must only be connected to the mains power supply by an authorised specialist. This person must be acquainted with the associated dangers.

→ Operate the machine only at the mains voltage given on the type plate.

**WARNING!**

Improper use of the machine can result in accidents, property damage and loss of production!

→ Provide a mains isolation system and emergency stop device during installation.

→ Install mains isolation system, emergency stop device and operating elements so that they are easily accessible.

→ Use a motor controller that switches off the motor in the event of a fault (e.g. blockage).

→ Use connecting leads that comply with the regulations of the country in which the machine is being installed.

→ Lay the connection cables so that no one can trip over them.

The electrical connection is made to a switch cabinet provided by the operating company. NOVEXX Solutions offers switch cabinets for control of up to three belts at the same time (AMC Series). It must be possible to synchronise the speed of belt conveyor and hold down conveyor.



An electronic motor controller <sup>1</sup> together with electric switches, emergency stop switches, fuses and interference suppression filters is required for operation of the wrap around conveyor.

## Setting the belt speed

The control element for setting the belt speed is installed by the operating company.

The belt speed is normally set using a potentiometer that is installed on the switch cabinet of the motor controller [15A].

→ Set the belt speed to 2 to 2.5 times the speed of the belt conveyor.



[15] Potentiometer (A) on the switch cabinet of the motor controller (example: NOVEXX Solutions, AMC Series).

1) Recommended: Lenze 532; The motor controller must be able to switch off the motor in the event of a fault.



# Cleaning & Maintenance

## CLEANING INSTRUCTIONS

### Safety



**WARNING!**

Dangerous situations may arise during maintenance and cleaning work. Accidents may occur due to mechanical or electrical effects if the relevant safety instructions are not observed!

- Switch off the machine before starting cleaning or maintenance work!
- Never allow liquid to get into the machine!
- Do not spray the machine with spray bottles or sprays! Use a cloth wetted with cleaning agent!
- Repairs to the machine must only be made by trained service technicians!

### Cleaning agent

**CAUTION!**

Strong cleaning agents may damage the wrap around conveyor.

- Do not use cleaning agents that could damage or destroy the wrap around conveyor.
- Do not use any scouring cleaning agents or any cleaning agents that could dissolve plastic.
- Do not use acid or alkaline solutions.

Part to be cleaned	Cleaning agent
Housing	Commercially available neutral cleaning agent
Belt	Cleaning solvent, alcohol, isopropyl alcohol

[Tab. 3] Recommended cleaning agents

### Cleaning interval

→ Clean the machine regularly.

The frequency depends on the following factors:

- Operating conditions
- Daily operating duration

## MAINTENANCE

### Maintenance instructions

The following parts of the wrap around conveyor are subject to wear and should be inspected and replaced, if necessary, at the given intervals.

Part	Inspection	Dimension	Coating	Item No.
Belt	Visual Inspection 1x per week	45 x 300	Vulkollan	0001361-01
		45 x 600		0001361-02
		95 x 300		0001361-03
		95 x 600		0001361-04
		150 x 300		0001361-05
		200 x 300		0001361-07
		200 x 600		0001361-08
		45 x 300		0000069-01
	45 x 600	0000069-07		
	95 x 300	0000069-10		
	95 x 600	Porol	0000069-16	
	150 x 300	0000069-71		
	200 x 300	0000069-73		
	200 x 600	0000069-74		
Toothed belts	Visual Inspection 1x per year	--	--	0002550-23

[Tab. 4] Wear parts and inspection intervals.

## Adjust/change belt

After replacement of the wrap around conveyor or after a very long period of operation, it has to be adjusted as follows. The belt replacement is described first, then the adjustment of the belt:

1. Switch off the wrap around conveyor at the main switch and lock the main switch to prevent accidental restarting.
2. Loosen the two tensioner screws [16A] to relieve the belt tension.

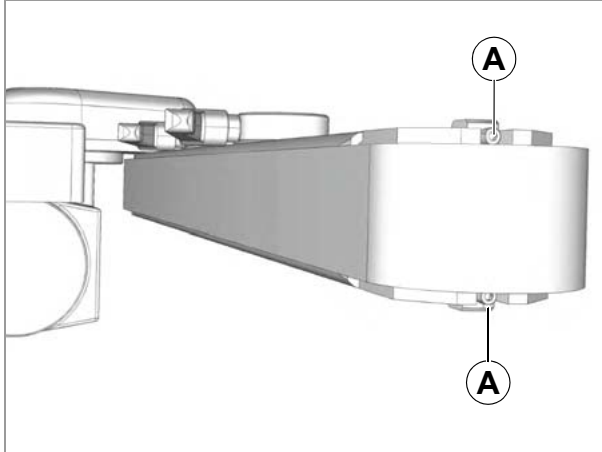

[16] Tensioner screws.

3. The tensioner roller moves inwards [17], the belt tension is relieved and the belt can be removed.



[17] Tensioner roller.

4. Install a new belt (use only OEM spare parts).
5. Tighten the two tensioner screws [16A] uniformly to tension the belt again.
  - ▮▮▮ Pay attention during tensioning that the two screws are tightened uniformly. If they are not tightened uniformly, the belt will run off-centre (check by turning manually).
  - ▮▮▮ If the belt runs off-centre, tighten the screw on the side to which the belt runs until the belt is running in the middle. Alternatively, the opposite screw can be loosened if the screw tightness/belt tension is already very high.

**Novexx Solutions GmbH**  
Ohmstraße 3  
85386 Eching  
Germany  
☎ +49-8165-925-0  
[www.novexx.com](http://www.novexx.com)

**NOVEXX**   
SOLUTIONS